

# Agenda



## County of Inyo Board of Supervisors

Board of Supervisors Room  
County Administrative Center  
224 North Edwards  
Independence, California

**NOTICE TO THE PUBLIC:** In order to minimize the spread of the COVID-19 virus, Governor Newsom has issued Executive Orders that temporarily suspend certain requirements of the Brown Act. Please be advised that the Board of Supervisors Chambers are closed to the public, the Board will be conducting its meetings exclusively online.

Board Members and Staff will participate via Zoom webinar, accessible to the public at <https://zoom.us/j/868254781>. Individuals will be asked to provide their name and an email address in order to access the videoconference. Anyone who does not want to provide their email address may use the following generic, non-functioning address to gain access: [donotreply@inyocounty.us](mailto:donotreply@inyocounty.us).

Anyone wishing to make either a general public comment or a comment on a specific agenda item prior to the meeting or as the item is being heard, may do so either in writing or by utilizing the Zoom "hand-waving feature" when appropriate during the meeting (the Chair will call on those who wish to speak). Written public comment, limited to **250 words or less**, may be emailed to the Assistant Clerk of the Board at [boardclerk@inyocounty.us](mailto:boardclerk@inyocounty.us). Your comments may or may not be read aloud, but all comments will be made a part of the record. Please make sure to submit a separate email for each item that you wish to comment upon.

**Public Notices:** (1) In Compliance with the Americans with Disabilities Act, if you need special assistance to participate in this meeting please contact the Clerk of the Board at (760) 878-0373. (28 CFR 35.102-35.104 ADA Title II). Notification 48 hours prior to the meeting will enable the County to make reasonable arrangements to ensure accessibility to this meeting. Should you because of a disability require appropriate alternative formatting of this agenda, please notify the Clerk of the Board 72 hours prior to the meeting to enable the County to make the agenda available in a reasonable alternative format. (Government Code Section 54954.2). (2) If a writing, that is a public record relating to an agenda item for an open session of a regular meeting of the Board of Supervisors, is distributed less than 72 hours prior to the meeting, the writing shall be available for public inspection at the Office of the Clerk of the Board of Supervisors, 224 N. Edwards, Independence, California and is available per Government Code § 54957.5(b)(1).

**Note:** Historically the Board does break for lunch; the timing of a lunch break is made at the discretion of the Chairperson and at the Board's convenience.

### **November 3, 2020 - 10:00 AM**

1. **PLEDGE OF ALLEGIANCE**
2. **PUBLIC COMMENT**
3. **COUNTY DEPARTMENT REPORTS** (Reports limited to two minutes)
4. **COVID-19 STAFF UPDATE**

### **CONSENT AGENDA** (Approval recommended by the County Administrator)

5. **Health & Human Services - Health/Prevention** - Request Board: A) declare The Lamar Companies (a.k.a Lamar) of Lancaster, CA a sole-source provider of billboard advertising; B) approve the contract between the County of Inyo and Lamar of Lancaster, CA for the provision of two vinyl panel billboards for the Tobacco Education Program in an amount not to exceed \$18,750.00 for the period of January 21, 2021 through July 7, 2021, contingent upon the Board's approval of future budgets; and C) authorize the County Administrator to sign, contingent upon all appropriate signatures being obtained.

6. **Public Works** - Request Board approve the plans and specifications for the Election Emergency Standby Generators Installation Project and authorize the Public Works Director to advertise the project.
7. **Public Works** - Request Board authorize a purchase order in an amount not to exceed \$337,414.72, payable to Coastline Equipment Company of Las Vegas, NV for one (1) new John Deere 672G Motor Grader with 6WD.
8. **Sheriff - Veterans Service Office** - Request Board authorize the Chairperson to sign the Medi-Cal Certificate of Compliance Fiscal Year 2020-2021 and Certificate of Compliance for Subvention Fiscal Year 2020-2021.

**DEPARTMENTAL** (To be considered at the Board's convenience)

9. **Health & Human Services - Social Services** - Request Board ratify and approve the agreement between the County of Inyo and Philips Lifeline of Framingham, MA for the provision of an Emergency Response Monitoring System in an amount not to exceed \$6,000 for the period of July 1, 2020 through June 30, 2021, and authorize the Chairperson to sign, contingent upon all appropriate signatures being obtained.
10. **Health & Human Services - Social Services** - Request Board award, ratify and approve the contract for the provision of urine sample collection devices (supplies) and laboratory services with Redwood Toxicology Laboratory, Inc. of Santa Rosa, CA in an amount not to exceed \$60,000 for the period of November 1, 2020 through June 30, 2024, contingent upon the Board's adoption of future budgets, and authorize the Chairperson to sign, contingent upon all appropriate signatures being obtained.
11. **Health & Human Services - First 5** - Request Board ratify and approve the Memorandum of Understanding between the County of Inyo First 5 Children and Families Commission and Bishop Friends of the Library, for the provision of the literacy program for Inyo County children from birth to age five (5) under Dolly Parton's Imagination Library Program, in an amount not to exceed \$1,886 for the period of November 1, 2020 through November 1, 2021, contingent upon the Board's approval of future budgets, and authorize the First 5 Director to sign, contingent upon all appropriate signatures being obtained.
12. **Clerk of the Board** - Request Board approve the minutes of the regular Board of Supervisors meeting of October 27, 2020.

**COMMENT** (Portion of the Agenda when the Board takes comment from the public and County staff)

13. **PUBLIC COMMENT**

**BOARD MEMBERS AND STAFF REPORTS**

14. **Inyo County Public Works** - Agenda for the Northern Inyo Airport Advisory Committee meeting scheduled for 5 p.m. at the Bishop Airport Terminal Building, 703 Airport Rd., Bishop.



# County of Inyo



## Health & Human Services - Health/Prevention

### CONSENT - ACTION REQUIRED

**MEETING:** November 3, 2020

**FROM:** Jenna Rhoads

**SUBJECT:** Sole Source Advertising Contract between County of Inyo and Lamar

---

**RECOMMENDED ACTION:**

Request Board: A) declare The Lamar Companies (a.k.a Lamar) of Lancaster, CA a sole-source provider of billboard advertising; B) approve the contract between the County of Inyo and Lamar of Lancaster, CA for the provision of two vinyl panel billboards for the Tobacco Education Program in an amount not to exceed \$18,750.00 for the period of January 21, 2021 through July 7, 2021, contingent upon the Board's approval of future budgets; and C) authorize the County Administrator to sign, contingent upon all appropriate signatures being obtained.

**SUMMARY/JUSTIFICATION:**

The Department requests this contract as a sole source contract due to the lack of availability of outdoor advertising space by other companies along the 395 corridor portion of Inyo County.

Outdoor advertising can play an important role in an advertising campaign, and the Tobacco Programs in both Inyo and Mono Counties have worked with Lamar to expand this messaging. For health advocates, billboards are best used for awareness campaigns or reminders that link the audience to other media that communicates an overall message. The HHS Tobacco Education Program has worked with their Mono County counterparts to split the cost of a Tobacco Education billboard just north of Bishop since fall of 2018, with Inyo County scheduled to take over payment from Mono County as of January 21, 2021. With the availability of a second billboard on 395 at Ft. Independence, Mono has agreed to continue payment for the Bishop billboard through December 31, 2020 so that Inyo can cover the costs associated with Independence. Combined, these two billboards now contribute to between 23,000 and 30,000 weekly impressions.

With this sole source contract, costs for both the Ft. Independence and Bishop billboards will be taken over by the Inyo County Tobacco Education program for the period of January 21, 2021 through July 7, 2021; This current arrangement is based on the agreement that the Mono County Tobacco Program will be obtaining their own billboard advertising in the coming months, and Inyo County will be able to discontinue use of one of its two billboards when the contract term is over.

**BACKGROUND/HISTORY OF BOARD ACTIONS:**

N/A

**ALTERNATIVES AND CONSEQUENCES OF NEGATIVE ACTION:**



The Board could deny this sole-source request. This would affect the collaboration of Mono and Inyo Counties on a joint advertising campaign for the Tobacco Education Program.

**OTHER AGENCY INVOLVEMENT:**

Mono County Public Health Department

**FINANCING:**

This will be paid exclusively with Tobacco Education Program funds. This expense will be budgeted in the Tobacco Control Budget (640317) in Paid Media (5263). No County General Funds will be used.

**ATTACHMENTS:**

1. Lamar Contract

**APPROVALS:**

Jenna Rhoads	Created/Initiated - 10/22/2020
Darcy Ellis	Approved - 10/22/2020
Jenna Rhoads	Approved - 10/22/2020
Marilyn Mann	Approved - 10/22/2020
Melissa Best-Baker	Approved - 10/22/2020
Marshall Rudolph	Approved - 10/23/2020
Marilyn Mann	Final Approval - 10/23/2020



**CONTRACT # 3500024**

CONTRACTED DIRECTLY BY ADVERTISER	
Customer #	696779-1
Name	COUNTY OF INYO
Address	568 WEST LINE ST
City/State/Zip	BISHOP, CA 93514
Contact	Clint Quilter
Email Address	
Phone #	(760) 872-1623
Fax #	
P.O./ Reference #	
Advertiser/Product	HEALTH & HUMAN SERVICES
Campaign	Opportunity: County of Inyo 1482 & 13644

Production/Other Services							
Department	Plant	Production Type	Misc	Service Dates	# Billing Periods	Invest Per Period	Cost
Vinyl	256 Lancaster, CA	VINYL PANEL 13644 12'3"X24'6"		01/21/21	1	\$750.00	\$750.00
Total Production/Other Services Costs:							\$750.00

Space										
# of Panels: 2									Billing Cycle: Every 4 weeks	
Panel # TAB ID	Market	Location	Illum	Media Type	Size	Misc	Service Dates	# Billing Periods	Invest Per Period	Cost
1482 350196	256-FT INDEPENDENCE, CA	HWY 395 EL 800' S/O CAMPGROUND ENTRANCE	Yes	Perm Bulletin	10' 6" x 36' 0"		01/21/21-07/07/21	6	\$1,500.00	\$9,000.00
13644 30484898	256-BISHOP, CA	HWY 395 SL 400' W/O PAHA LANE	No	Junior Bulletin	12' 3" x 24' 6"		01/21/21-07/07/21	6	\$1,500.00	\$9,000.00
Total Space Costs:									\$18,000.00	
<b>Total Costs:</b>									<b>\$18,750.00</b>	

**Special Considerations:**

Advertiser authorizes and instructs The Lamar Companies (Lamar) to display in good and workmanlike manner, and to maintain for the terms set forth above, outdoor advertising displays described above or on the attached list. In consideration thereof, Advertiser agrees to pay Lamar all contracted amounts within thirty (30) days after the date of billing. Advertiser acknowledges and agrees to be bound by the terms and conditions on all pages of this contract.

The Agency representing this Advertiser in the contract executes this contract as an agent for a disclosed principal, but hereby expressly agrees to be liable jointly and severally and in solidio with Advertiser for the full and faithful performance of Advertiser's obligations hereunder. Agency waives notice of default and consents to all extensions of payment.

The undersigned representative or agent of Advertiser hereby warrants to Lamar that he/she is the Advertising Director (Officer/Title) of the Advertiser and is authorized to execute this contract on behalf of the Advertiser.

Customer:	COUNTY OF INYO
Signature:	(signature above)
Name:	(print name above)
Date:	(date above)





**CONTRACT # 3500024**

**THE LAMAR COMPANIES**

This contract is NOT BINDING UNTIL ACCEPTED by a Lamar General Manager.

ACCOUNT EXECUTIVE: Amanda Petryshyn

GENERAL MANAGER

DATE

### STANDARD CONDITIONS

- 1. Late Artwork:** The Advertiser must provide or approve art work, materials and installation instructions ten (10) days prior to the initial Service Date. In the case of default in furnishing or approval of art work by Advertiser, billing will occur on the initial Service Date.
- 2. Copyright/Trademark:** Advertiser warrants that all approved designs do not infringe upon any trademark or copyright, state or federal. Advertiser agrees to defend, indemnify and hold Lamar free and harmless from any and all loss, liability, claims and demands, including attorney's fees arising out of the character contents or subject matter of any copy displayed or produced pursuant to this contract.
- 3. Payment Terms:** Lamar will, from time to time at intervals following commencement of service, bill Advertiser at the address on the face hereof. Advertiser will pay Lamar within thirty (30) days after the date of invoice. If Advertiser fails to pay any invoice when it is due, in addition to amounts payable thereunder, Advertiser will promptly reimburse collection costs, including reasonable attorney's fees plus a monthly service charge at the rate of 1.5% of the outstanding balance of the invoice to the extent permitted by applicable law. Delinquent payment will be considered a breach of this contract. Payments will be applied as designated by the Advertiser; non designated payments will be applied to the oldest invoices outstanding.
- 4. Service Interruptions:** If Lamar is prevented from posting or maintaining any of the spaces by causes beyond its control of whatever nature, including but not limited to acts of God, strikes, work stoppages or picketing, or in the event of damage or destruction of any of the spaces, or in the event Lamar is unable to deliver any portion of the service required in this contract, including buses in repair, or maintenance, this contract shall not terminate. Credit shall be allowed to Advertiser at the standard rates of Lamar for such space or service for the period that such space or service shall not be furnished or shall be discontinued or suspended. In the case of illumination, should there be more than a 50% loss of illumination, a 20% pro-rata credit based on four week billing will be given. If this contract requires illumination, it will be provided from dusk until 11:00p.m. Lamar may discharge this credit, at its option, by furnishing advertising service on substitute space, to be reasonably approved by Advertiser, or by extending the term of the advertising service on the same space for a period beyond the expiration date. The substituted or extended service shall be of a value equal to the amount of such credit.
- 5. Entire Agreement:** This contract, all pages, constitutes the entire agreement between Lamar and Advertiser. Lamar shall not be bound by any stipulations, conditions, or agreements not set forth in this contract. Waiver by Lamar of any breach of any provision shall not constitute a waiver of any other breach of that provision or any other provision.
- 6. Copy Acceptance:** Lamar reserves the right to determine if copy and design are in good taste and within the moral standards of the individual communities in which it is to be displayed. Lamar reserves the right to reject or remove any copy either before or after installation, including immediate termination of this contract.
- 7. Termination:** All contracts are non-cancellable by Advertiser without the written consent of Lamar. Breach of any provisions contained in this contract may result in cancellation of this contract by Lamar.
- 8. Materials/Storage:** Production materials will be held at customer's written request. Storage fees may apply.
- 9. Installation Lead Time:** A leeway of five (5) working days from the initial Service Date is required to complete the installation of all non-digital displays.
- 10. Customer Provided Production:** The Advertiser is responsible for producing and shipping copy production. Advertiser is responsible for all space costs involved in the event production does not reach Lamar by the established Service Dates. These materials must be produced in compliance with Lamar production specifications and must come with a 60 day warranty against fading and tearing.
- 11. Bulletin Enhancements:** Cutouts/extensions, where allowed, are limited in size to 5 feet above, and 2 feet to the sides and 1 foot below normal display area. The basic fabrication charge is for a maximum 12 months.
- 12. Assignment:** Advertiser shall not sublet, resell, transfer, donate or assign any advertising space without the prior written consent of Lamar.





# County of Inyo



## Public Works

### CONSENT - ACTION REQUIRED

**MEETING:** November 3, 2020

**FROM:** Greg Waters

**SUBJECT:** Request Board authorize the Public Works Director to solicit bids for the installation portion of the Election Emergency Standby Generators Project based on the attached bid package.

---

**RECOMMENDED ACTION:**

Request Board approve the plans and specifications for the Election Emergency Standby Generators Installation Project and authorize the Public Works Director to advertise the project.

**SUMMARY/JUSTIFICATION:**

The electrical utilities have been deliberately shutting down the power grid during periods of high wind to mitigate the chance of arcing power lines and the resultant fires that previously resulted in massive loss of life and property damage in Paradise, California in November 2018. The Elections Department has obtained a grant from the State of California to purchase and install generators at all affected voting venues. The Board approved a Purchase Order at the August 25th, 2020 meeting and the generators have been ordered.

The installation contract for the generators and automatic transfer switches will be put out to bid as an OFCI (Owner Furnished, Contractor Installed) contract. The benefit of this method of delivery is two-fold, it allows the fast-tracking of the acquisition of the generators, which are long lead items, and it will mitigate the overall cost of the project, as the procurement of the generators is a majority of the cost of the work.

**BACKGROUND/HISTORY OF BOARD ACTIONS:**

As a result of the loss of life and property damage from the Camp Fire in Paradise, CA in November 2018, electrical utility companies have been shutting off the power during periods of high wind in Inyo County. One of the unintended consequences of these de-energizations of the power grid is that it could result in the disenfranchisement of Inyo County voters should it occur on an Election Day. In order to mitigate this threat, the Elections Department has obtained a grant from the State of California to purchase and install emergency standby generators at all of the affected voting venues in Inyo County

**ALTERNATIVES AND CONSEQUENCES OF NEGATIVE ACTION:**

The Board could decline to authorize the Public Works Director to advertise the bid package for the installation of the Elections Emergency Standby Generators, the grant money would expire, and the voters of Inyo County could be disenfranchised by the inability to operate the voting venues on election day, should a black out occur.

**OTHER AGENCY INVOLVEMENT:**

**FINANCING:**

The funding source for this purchase is the Elections Voting Systems grant budget (621250) for FY 20-21

**ATTACHMENTS:**

1. Election Generators Installation Bid Package

**APPROVALS:**

Greg Waters	Created/Initiated - 10/15/2020
Darcy Ellis	Approved - 10/15/2020
Greg Waters	Approved - 10/22/2020
Michael Errante	Approved - 10/22/2020
Greg Waters	Approved - 10/22/2020
John Vallejo	Approved - 10/26/2020
Aaron Holmberg	Approved - 10/27/2020
Amy Shepherd	Final Approval - 10/27/2020

# **BID PACKAGE AND SPECIAL PROVISIONS**



FOR CONSTRUCTION OF

## **ELECTION EMERGENCY STANDBY GENERATORS INSTALLATION PROJECT**

**Project No. ZP-20-012**

**FOR USE IN CONNECTION WITH INYO COUNTY  
STANDARD SPECIFICATIONS, DATED OCTOBER 2015,  
GENERAL PREVAILING WAGE RATES IN EFFECT  
ON THE DATE THE WORK IS ACCOMPLISHED**

October, 2020

**Prepared By: Inyo County Public Works**

[PAGE INTENTIONALLY LEFT BLANK]

# TABLE OF CONTENTS

NOTICE INVITING BIDS.....	vii
BID PROPOSAL FORM .....	3
BID BOND .....	11
CASHIER'S OR CERTIFIED CHECK .....	13
DESIGNATION OF SUBCONTRACTORS.....	14
CERTIFICATION REGARDING EQUAL EMPLOYMENT OPPORTUNITY.....	15
CONTRACTOR'S LABOR CODE CERTIFICATION.....	16
CONTRACTOR AND SUBCONTRACTOR REGISTRATION.....	17
NON-COLLUSION AFFIDAVIT .....	18
PUBLIC CONTRACT CODE SECTION 10162 QUESTIONNAIRE.....	19
PUBLIC CONTRACT CODE STATEMENT (SECTION 10232) .....	20
LOCAL BUSINESS PREFERENCES .....	21
SMALL BUSINESS ENTERPRISE COMMITMENTS .....	24
FINAL REPORT – UTILIZATION OF SMALL BUSINESS ENTERPRISES.....	26
CONTRACT AND BOND FORMS.....	29
SPECIAL PROVISIONS.....	31
SPECIFICATIONS APPROVAL.....	33
INTRODUCTION / GENERAL: .....	35
PROJECT DESCRIPTION:.....	35
SECTION 3 CONTRACT AWARD AND EXECUTION.....	35
3-1.04    CONTRACT AWARD.....	35
3-1.05    CONTRACT BONDS (PUB CONT CODE §§ 10221 AND 10222).....	35
3-1.06    CONTRACTOR LICENSE.....	36
3-1.07    INSURANCE POLICIES.....	36
3-1.08    SMALL BUSINESS ENTERPRISE PARTICIPATION .....	36
3-1.18    CONTRACT EXECUTION.....	39
SECTION 7    LEGAL RELATIONS AND RESPONSIBILITY TO THE PUBLIC.....	39
7-1.02K (2)    WAGES.....	39
ADD to 7-1.02K (3)    Certified Payroll Records (Labor Code §1776).....	39
7-1.05    INDEMNIFICATION .....	40
7-1.06    INSURANCE .....	40
SECTION 8    PROSECUTION AND PROGRESS.....	41



ADD TO 8-1.05 TIME.....41  
8-1.10 LIQUIDATED DAMAGES .....41  
PUBLIC CONTRACT CODE SECTION 9204..... 42  
Project Scope .....45

# **NOTICE INVITING BIDS**

**For The**

## **ELECTION EMERGENCY STANDBY GENERATORS INSTALLATION PROJECT**

**Independence, CA**

[PAGE INTENTIONALLY LEFT BLANK]

COUNTY OF INYO

DEPARTMENT OF PUBLIC WORKS

**NOTICE INVITING BIDS**

The Inyo County Public Works Department is soliciting bids for:

**ELECTION EMERGENCY STANDBY GENERATORS INSTALLATION PROJECT**

Bid Packages, which include the Notice Inviting Bids, Bid Proposal Forms, Contract and Bond Forms, Special Provisions, and Plans, may only be obtained from the Inyo County (County) Public Works Department (Department) at 168 North Edwards, P. O. Drawer Q, Independence, CA 93526, telephone (760) 878-0201. A non-refundable price of \$100.00 will be charged for each set of Bid Packages requested. The Bid Packages are available for inspection at the Department during regular business hours. Checks are to be made out to "Inyo County Public Works Department." The Bid Package is also available at no charge at the County of Inyo website at <https://www.inyocounty.us/services/county-administration/bid-request-rfp>. Bidders who obtain Bid Packages over the internet are responsible for notifying Inyo County Public Works Department that they are plan holders. Bidders who fail to notify the Department that they are plan holders may not be notified should any Addenda be issued. If the Department issues any Addenda to the Bid Package that is not acknowledged, the Bid Proposal may be rejected. This project is subject to the State of California Department of Industrial Relations (DIR) prevailing wage labor rates.

**Bids must be submitted in a sealed envelope clearly marked with the bidder's name and address, the word "BID", and the Project Title:**

**ELECTION EMERGENCY STANDBY GENERATORS INSTALLATION PROJECT**

To be considered, **bids must be received by the Inyo County Clerk of the Board of Supervisors, 224 North Edwards Street (mailing address: P.O. Box N), Independence, California 93526 at or before 3:30 P.M. on December 2nd, 2020** at which time they will be publicly opened and read aloud. No oral, telegraphic, telephonic, or fax proposals or modifications will be accepted.

**General Work Description:** The project is a design-build scope consists of the installation of five generators and transfer switches at five locations in Inyo County, California.

A job walk will be held on **November 10th, 2020 at 10:00 a.m.** starting at the Tri-County Fairgrounds, Bishop, CA. ***Bidders will be responsible for inclusion in their bids any costs that would be identifiable during the job walk, whether they choose to attend or not.***

All project work is more particularly described in the plans and special provisions. All of the work shall be in accordance with all applicable Federal, State, and local laws, codes, and regulations.

For technical questions related to project work, site conditions, or to schedule a site visit, please contact Greg Waters of the Inyo County Public Works Department at [gwaters@inyocounty.us](mailto:gwaters@inyocounty.us)

Bids shall conform to and be responsive to the Contract Documents. Bids are required for the entire work described in the Contract Documents.

Each Bid must be submitted on the Bid Proposal Forms furnished as a part of the Bid Package. Each Bid must be accompanied by a Proposal Guarantee in the amount and form described in the Bid Package, in an amount not less than 10% of the amount of the bid, made payable to the order of the County of Inyo. The check or bond shall be given as security that the bidder will enter into the Contract with the County and furnish the required Faithful Performance Bond, Labor and Materials Payment Bond, Certificates and/or original endorsements of insurance, or other required documents. The check or bond may be retained by the County for sixty (60) days or until the Contract is fully executed by the successful bidder and the County, whichever first occurs.

The successful bidder shall be required to furnish a Faithful Performance Bond and a Labor and Materials Payment Bond on the forms provided in the Bid Package and in the amount of 100% of the Contract amount.

The successful bidder must be licensed as required by law, and consistent with the Contract Documents, at the time the contract is awarded, which license shall be a current California Class B - General Building Contractor License (with a listed subcontractor who holds a California C-10 Commercial Electrical Contractors License with significant experience in the installation of generators and automatic transfer switches) or a California C10 - Commercial Electrical Contractors License with significant experience in the installation of generators and automatic transfer switches that will be required for complete performance of all of the work in accordance with the Contract Documents, and if applicable, a joint venture license as defined in the **Business and Professions Code, Section 7029**. Failure of the bidder to obtain proper and adequate licensing for an award of a contract shall constitute failure to execute the contract and shall result in the forfeiture of the security of the bidder.

In addition to the requirements set forth in this Notice Inviting Bids, all bids shall be subject to the requirements set forth in the Special Provisions, Standard Specifications of the Inyo County Public Works Department, dated October, 2015, Contract Documents and other applicable law.

The Contract is subject to the State Contract nondiscrimination and compliance requirements pursuant to **Government Code, Section 12990**, and other applicable law.

The Contract is also subject to and incorporates by reference the provisions of **Public Contract Code, Section 22300**, pursuant to which, the Contractor is permitted to substitute securities for earned retention or have them placed in escrow at the Contractor's expense, as also set forth in Section 1150.15 of the Standard Specifications.

Pursuant to **Section 1725.5 of the Labor Code**, the bidder is required to certify that they, and all subcontractors listed on the submitted Bid Form documents, are registered with the California Department of Industrial Relations.

Pursuant to **Section 1773 of the Labor Code**, the general prevailing wage rates in Inyo County have been determined by the Director of the State Department of Industrial Relations. These wage rates appear in the Department of Transportation publication entitled "General Prevailing Wage Rates," in effect at the time the project is advertised. Future effective wage rates, which have been predetermined and are on file with the State Department of Industrial Relations are referenced, but not printed, in said publication. Such rates of wages are on file with the State Department of Industrial Relations and the Public Works Department of the County of Inyo and are available to any interested party upon request.

Inyo County reserves the right at any stage of these proceedings to reject any or all Bids or to waive any immaterial defect in any Bid if it is deemed to be in the best interest of the County.

Each bidder must supply all the information required by the Contract Documents, Special Provisions and Standard Specifications.

County of Inyo  
Department of Public Works

Michael Errante, P.E. Digitally signed by Michael Errante, P.E.  
Date: 2020.10.23 13:00:06 -0700

Michael Errante  
Director

Dated: October 23rd, 2020

[PAGE INTENTIONALLY LEFT BLANK]



# **BID PROPOSAL FORMS**

**For The**

**ELECTION EMERGENCY STANDBY GENERATORS  
INSTALLATION PROJECT**

**Inyo County, CA**

[PAGE INTENTIONALLY LEFT BLANK]

# BID PROPOSAL FORM

TO: COUNTY OF INYO  
Attn.: Inyo County Clerk of Board of Supervisors  
224 North Edwards Street, P.O. Box N  
Independence, California 93526  
(Herein called the "County")

FROM: \_\_\_\_\_  
\_\_\_\_\_  
\_\_\_\_\_  
(Herein called "Bidder")

FOR: **ELECTION EMERGENCY STANDBY GENERATORS INSTALLATION PROJECT**  
(Herein called "Project")

In submitting this Bid, Bidder understands and agrees that:

- 1. BID DEADLINE.** Bids must be received no later than 3:30 P.M. on December 2nd, 2020 by the **Inyo County Assistant Board Clerk, 224 North Edwards Street (mailing address: P.O. Box N), Independence, CA 93526**, at which time they will be publicly opened and read aloud. No oral, electronic, telephonic or fax proposals or modifications will be accepted.
- 2. BID AMOUNT TOTAL.** The total amount of this Bid for provision of the services and/or materials for completion of the Project in accordance with the Contract Documents is set forth herein as:
- 3. BID ADDITIVES.** The County reserves the right to award the base bid and any combination, including neither, of the bid additives.

**BASE PROJECT BID FORM – UNIT PRICE BID:**

ABBREVIATIONS:

LS = LUMP SUM

SF = SQUARE FEET

LF = LINEAR FEET

<b>Item No.</b>	<b>Description</b>	<b>Quantity</b>	<b>Unit</b>	<b>Unit Price</b>	<b>Total Price</b>
1	Mobilization and Demobilization	1	LS	\$	\$
2	Tri-County Fairgrounds - Complete	1	LS	\$	\$
3	Big Pine Town Hall - Complete	1	LS	\$	\$
4	Independence Courthouse - Complete	1	LS	\$	\$
5	Annex Building - Complete	1	LS	\$	\$
5	Statham Hall - Complete	1	LS	\$	\$
5	Start-Up, Commissioning, and Training	1	LS	\$	\$
<b>TOTAL BASE BID AMOUNT:</b>					\$

**PROJECT BID AMOUNT - UNIT PRICE BID:**

BID TOTAL (IN NUMBERS): \$ \_\_\_\_\_

BID TOTAL (IN WORDS): \_\_\_\_\_

\_\_\_\_\_

No provision in this section is intended or shall be construed to alter the terms and conditions specified in the Contract Documents for payment of any amounts in the event the Project contract is awarded to Bidder pursuant to this Bid.

**3. INCLUSION OF ALL COSTS.** This Bid includes all costs for all labor, materials, tools, taxes, insurance, transportation, and other related supplies and services to perform all services and provide all materials as required by, and in accordance with, the Contract Documents for the Project.

**4. CONTRACT DOCUMENTS.** The Contract Documents shall constitute the Contract between the parties, which will come into full force and effect upon acceptance, approval, and execution by the Inyo County Board of Supervisors. The Contract Documents are complementary and are incorporated herein by reference and made a part hereof with like force and effect as if all of said documents were set forth in full herein. The Contract Documents include all documents defined as "Contract Documents" in the Standard Specifications of the Inyo County Public Works Department, dated October, 2015.

**5. ACCEPTANCE.** County reserves the right to reject any and all Bids, or part of any Bid, to postpone the scheduled Bid deadline date(s), to make an award in its own best interest, and to waive any irregularities or technicalities that do not significantly affect or alter the substance of an otherwise responsible Bid and that would not affect a Bidder's ability to perform the work adequately as specified. However, this Bid shall remain open and shall not be withdrawn for a period of sixty (60) calendar days after the date designated in the Notice Inviting Bids for publicly opening this Bid. If Bidder receives written notice of the award of the Project Contract to Bidder on or before the sixtieth day, Bidder shall execute the Contract and deliver to County the executed Contract and all of the bonds, certificates and/or endorsements of insurance coverage, and other required documents no later than fifteen (15) calendar days after the date on which Bidder receives such notice.

This solicitation in no way obligates County to award a Bid Contract described herein, nor will County assume any liability for the costs incurred in the preparation and transmittal of Bids in response to this solicitation. County reserves the right to not accept any Bid, to reject any or all Bids, to reject any part of any Bid proposal, to negotiate and modify any Bid, and to waive any defects or irregularities in any Bid at County's sole discretion. Furthermore, County shall have the sole discretion to award a Bid Contract as it may deem appropriate to best serve the interests of County. In this regard, County may consider demonstrated quality of work, responsiveness, comparable experience, professional qualifications, references, and proposed fees. Awards will not be based on cost alone. County does not guarantee a minimum or maximum dollar value for any Contract(s) resulting from this solicitation.

If the Contract Documents require or permit this Bid to include two or more Alternates, County reserves the right to award the Contract for that Alternate which County, in its sole discretion, determines at the time of award to be in County's best interest.

**6. TIME OF COMPLETION.** The Bidder further specifically agrees to complete all the work no later than the Time for Completion specified in the Contract Special Provisions.

**7. ADDENDA.** The Bidder acknowledges receipt of the following Addenda and has provided for all Addenda changes in this Bid.

---

---

(Fill in Addendum numbers and dates Addenda have been received.  
If none have been received, enter "NONE".)

**WARNING:** IF AN ADDENDUM OR ADDENDA HAVE BEEN ISSUED BY THE COUNTY AND NOT NOTED ABOVE AS BEING RECEIVED BY THE BIDDER, THIS PROPOSAL MAY BE REJECTED.

**8. BIDDER'S BUSINESS INFORMATION.** Bidder provides the following information concerning its business:

Bidder's Name: \_\_\_\_\_

Address: \_\_\_\_\_

\_\_\_\_\_ Zip Code \_\_\_\_\_  
(The above address will be used to send notices or requests for additional information.)

Telephone: (     ) \_\_\_\_\_

Federal Identification No.: \_\_\_\_\_

Contractor's License No.: \_\_\_\_\_ State: \_\_\_\_\_

Classification: \_\_\_\_\_ Expiration Date: \_\_\_\_\_

Type of Business (check one):

Individual (   ), Partnership (   ), Joint Venture (   )

Corporation (   ), Other (Specify) : \_\_\_\_\_ (   )

Owners, Officers, Partners, or Other Authorized Representatives:

**IMPORTANT NOTICE:** If bidder or other interested person is a corporation, state legal name of corporation above and list below, names of the president, secretary, treasurer, and chief executive officer/manager thereof; if a partnership, joint venture, or other business entity, state true name of firm above and list below, names of all partners, joint venturers, or for other entities, parties having authority to act on behalf of the entity, such as officers, owners, directors; if bidder or other interested person is an individual, state first, middle, and last names in full above and write "N/A" below.

\_\_\_\_\_  
\_\_\_\_\_  
\_\_\_\_\_  
\_\_\_\_\_

**9. PROPOSAL GUARANTEE.** As security for the Bid, this Bid includes one of the following proposal guarantee instruments (the "Proposal Guarantee"), in the amount required by this section, as checked:

- (a) \_\_\_\_\_ Bid Bond from a corporate surety admitted to issue such bonds in the State of California; or

- (b) \_\_\_\_ Cashier's Check or Certified Check, made payable to the County of Inyo, attached to the form entitled Cashier's or Certified Check; or
- (c) \_\_\_\_ Cash, in legal tender of the United States of America, enclosed in a separate envelope marked " Cash Proposal Guarantee."

The Proposal Guarantee is in the amount of Ten Percent (10%) of the total amount of the Bid. If the Contract Documents require or permit this Bid to include two or more Alternates, the amount of the Proposal Guarantee must not be less than Ten Percent (10%) of the amount of the bid total submitted for the alternate having the highest total bid amount. Only one form of Proposal Guarantee may be submitted with each Bid.

Bidder hereby agrees that County shall be entitled to payment by forfeiture of the Proposal Guarantee if County awards the Project Contract to Bidder, but Bidder fails or refuses to execute the Contract and/or furnish all of the bonds, certificates and/or endorsements of insurance coverage, and other required documents no later than fifteen (15) calendar days after the date on which Bidder receives notice of the award from County.

**10. BID PROTEST.** In the event a dispute arises concerning the bid process prior to the award of the contract, the party wishing resolution of the dispute shall submit an appeal request in writing to the County Director of Purchasing. Bidder may appeal the recommended award or denial of award, provided the following stipulations are met:

1. Only a bidder who has actually submitted a Bid Proposal is eligible to submit an appeal request/bid protest against another bidder. Subcontractors are not eligible to submit bid protests. A bidder may not rely on the bid protest submitted by another bidder, but must timely pursue its own protest.
2. Appeal must be in writing. The appeal must contain a complete statement of the basis for the protest and all supporting documentation. Materials submitted after the Bid Protest Deadline will not be considered. The protest must refer to the specific portion or portions of the Contract Documents upon which the protest is based. The protest must include the name, address and telephone number of the person representing the protesting bidder if different from the protesting bidder.
3. A copy of the protest and all supporting documents must also be transmitted by fax or by e-mail, by or before the Bid Protest Deadline, to the protested bidder and any other bidder who has a reasonable prospect of receiving an award depending upon the outcome of the protest.
4. Must be submitted within ten (10) calendar days of the date of the recommended award or denial of award letters.
5. An appeal of a denial of award can only be brought on the following grounds:
  - a. Failure to follow the selection procedures and adhere to requirements specified in the Bid Package or any addenda or amendments.



- b. There has been a violation of conflict of interest as provided by California Government Code Section 87100 et seq.
  - c. A violation of State or Federal law.
6. Appeals will not be accepted for any other reasons than those stated above. All appeals must be sent to:

Clint Quilter, Director  
County of Inyo  
Purchasing Department  
224 N. Edwards St.  
Independence, CA 93526

County's Purchasing Director shall make a decision concerning the appeal, and notify the Proposer making the appeal, within a reasonable timeframe prior to the tentatively scheduled date for awarding the contract. The decision of County's Purchasing Director shall be deemed final.

**11. ADDITIONAL REQUIRED DOCUMENTS.** Bidder agrees that, in addition to the Proposal Guarantee, Bidder is required to submit, as a part of this Bid, the following forms properly completed, and signed as required, all of which accompany this Bid Proposal Form and are incorporated herein by this reference:

- (1) Designation of Subcontractors (Public Contract Code section 4100 et seq.)
- (2) Certification Regarding Equal Employment Opportunity (Government Code section 12900 et seq., sections 11135-11139.5)
- (3) Contractor's Labor Code Certification (Labor Code section 3700)
- (4) Contractor and Subcontractor Dept. of Industrial Relations (DIR) Registration (Labor Code section 1725.5)
- (5) Non-Collusion Affidavit (Public Contract Code Section 7106)
- (6) Public Contract Code Section 10162 Questionnaire
- (7) Public Contract Code Statement (Section 10232)
- (8) Small Business Enterprise Commitment (Construction Contracts)
- (9) Small Business Enterprise Final Report of Utilization of Small Business Enterprise

**12. DEFINITIONS.** The definition and meaning of the words used in this Bid Proposal Form are the same as set forth in **Section 1070, "Abbreviations, Symbols and Definitions,"** of the Standard Specifications of the Inyo County Public Works Department, dated October, 2015.

---

THE UNDERSIGNED HEREBY DECLARES, UNDER PENALTY OF PERJURY ACCORDING TO THE LAWS OF THE STATE OF CALIFORNIA, THAT THE STATEMENTS, DESIGNATIONS, CERTIFICATIONS, AND REPRESENTATIONS MADE IN THIS BID PROPOSAL, INCLUDING ALL ATTACHMENTS, ARE TRUE AND CORRECT AND HE OR SHE IS THE INDIVIDUAL, MANAGING PARTNER, CORPORATE OFFICER, OR OTHER REPRESENTATIVE, DULY AUTHORIZED BY LAW TO MAKE THIS BID ON BEHALF OF BIDDER, AND BY SIGNING BELOW, MAKES THIS BID ON BEHALF OF BIDDER ACCORDING TO ALL OF THE TERMS AND CONDITIONS SET FORTH OR INCORPORATED BY REFERENCE HEREIN.

\_\_\_\_\_  
(Signature of Authorized Person)

\_\_\_\_\_  
(Date)

\_\_\_\_\_  
(Printed Name)

\_\_\_\_\_  
(Printed Title)

**INYO COUNTY PUBLIC WORKS DEPARTMENT**

**ELECTION EMERGENCY STANDBY GENERATORS INSTALLATION PROJECT**

**BID BOND**  
**(BID PROPOSAL GUARANTEE)**

(Not required if a certified or cashier's check or a cash deposit accompanies the bid as a proposal guarantee)

KNOW ALL MEN BY THESE PRESENTS: That we, \_\_\_\_\_

\_\_\_\_\_ as Principal, and  
(Name of Bidder)

\_\_\_\_\_ (Name of Corporate Surety)

as Corporate Surety admitted to issue such bonds in the State of California, are held and firmly bound unto the County of Inyo, State of California, in the sum of \_\_\_\_\_ dollars (\$ \_\_\_\_\_) for the payment whereof we hereby bind ourselves, our successors, heirs, executors, and administrators, jointly and severally, firmly by these presents.

The condition of the foregoing obligation is such that whereas the above bounded Principal is about to submit to the Board of Supervisors of the County of Inyo a bid for the construction of the **ELECTION EMERGENCY STANDBY GENERATORS INSTALLATION PROJECT**, in compliance with the Contract therefor:

Now, if the bid of the Principal shall be accepted and the Contract awarded to the Principal by said Board of Supervisors, and if the Principal shall fail or neglect to enter into the Contract therefor in accordance with the terms of the Principal's bid and the terms set forth in the Bid Package, or to furnish the required Faithful Performance and Labor and Materials Payment Bonds, Certificates of insurance, and other required documents, to the satisfaction of the Board of Supervisors of said County, no later than fifteen (15) calendar days after the Principal has received notice from the County that the Contract has been awarded to the Principal, then the sum guaranteed by this Bond is forfeited to the County of Inyo.

It is expressly agreed and understood that any errors, clerical, mathematical, or otherwise, in the bid shall not be or constitute a defense to a forfeiture of this Bond.

WITNESS our hands and seals this \_\_\_\_\_ day of \_\_\_\_\_, 20 \_\_\_\_ A.D.

\_\_\_\_\_  
Principal

(SEAL)

By: \_\_\_\_\_  
(Title of Authorized Person)

\_\_\_\_\_  
(Address for Notices to be Sent)

\_\_\_\_\_  
Surety

(SEAL)

By: \_\_\_\_\_  
(Title of Authorized Person)

\_\_\_\_\_  
(Address for Notices to be Sent)

**NOTE:**

**THE SIGNATURES OF THE PRINCIPAL (BIDDER) AND THE SURETY MUST EACH BE ACKNOWLEDGED BEFORE A NOTARY PUBLIC ( OR OTHER OFFICER AUTHORIZED UNDER CALIFORNIA LAW ) AND THE ACKNOWLEDGMENTS MUST BE ATTACHED TO THIS BOND.** The Bid Bond must be executed on this form by a corporate surety admitted to issue such bonds in the State of California. No substitutions will be accepted. If an attorney-in-fact signs for the surety, an acknowledged statement from the surety appointing and empowering the attorney-in-fact to execute such bonds in such amounts on behalf of the surety, must accompany the Bid Bond.

**ADDRESS OF COUNTY FOR NOTICES TO BE SENT:**

**County of Inyo (Attn.: Public Works Director)  
224 North Edwards Street, P.O. Box N  
Independence, California 93526**

**ELECTION EMERGENCY STANDBY GENERATORS INSTALLATION PROJECT**

**CASHIER'S OR CERTIFIED CHECK  
(BID PROPOSAL GUARANTEE)**

(Not required if Bid Bond accompanies the bid as a proposal guarantee)

A cashier's or certified check in the amount required as a proposal guarantee for the Bid and made payable to the County of Inyo is attached below:

[ ]

**ATTACH CHECK HERE**

[ ]

Bidder (print name) : \_\_\_\_\_

**ELECTION EMERGENCY STANDBY GENERATORS INSTALLATION PROJECT**

**DESIGNATION OF SUBCONTRACTORS**

In compliance with the provisions of the **Subletting and Subcontracting Fair Practices Act (Section 4100 et. seq. of the Public Contract Code of the State of California)**, the undersigned bidder has set forth below the full name, and the location of the place of business of each Subcontractor who will perform work or labor or render service to the Prime Contractor in or about the construction of the work or improvement, or a Subcontractor licensed by the State of California who, under subcontract to the Prime Contractor, specifically fabricates and installs a portion of the work or improvement according to detailed drawings contained in the Plans and Specifications to which the attached bid is responsive, and the portion of the work which will be done by each Subcontractor for each subcontract in excess of one-half of one percent of the Prime Contractor's total bid, or \$10,000.00, whichever is greater.

The Bidder understands that if he fails to specify a Subcontractor for any portion of the work to be performed under the Contract in excess of one-half of one percent of his bid, or \$10,000.00, whichever is greater, he shall be deemed to have agreed to perform such portion himself, and that he shall not be permitted to sublet or subcontract that portion of the work except in cases of public emergency or necessity, and then only after a finding, produced to writing as a public record of the Awarding Authority, setting forth the facts constituting the emergency or necessity. If no Subcontractors are to be employed on the project, enter the word "none".

ITEM NO.	DESCRIPTION OF WORK	% OF TOTAL CONTRACT	SUBCONTRACTOR'S LICENSE TYPE, NUMBER, EXPIRATION DATE	NAME, ADDRESS, PHONE NUMBER

\_\_\_\_\_  
Signature of Authorized Person)

\_\_\_\_\_  
(Title)

\_\_\_\_\_  
(Printed Name)

\_\_\_\_\_  
(Date)

# **CERTIFICATION REGARDING EQUAL EMPLOYMENT OPPORTUNITY**

**(Government Code Section 12900 et seq., Sections 11135-11139.7)**

## **ELECTION EMERGENCY STANDBY GENERATORS INSTALLATION PROJECT**

During the performance of this Contract, the Contractor and its subcontractors shall not unlawfully deny the Contract's benefits to any person, nor shall any person be unlawfully subjected to discrimination under the contract and its performance on the basis of religion, color, ethnic group identification, sex, age, or disability. In addition, the Contractor and its subcontractors shall not discriminate unlawfully against any employee or applicant for employment because of race, religious creed, color, national origin, ancestry, physical disability, mental disability, medical condition, marital status, age, or sex. The Contractor shall insure that the evaluation and treatment of employees and applicants for employment are free from such discrimination.

The Contractor shall comply with the provisions of the Fair Employment and Housing Act (**Government Code, Section 12900 et seq.**), the regulations promulgated thereunder (**California Code of Regulations, Title 2, Section 7285.0 et seq.**), and the Provisions of **Article 9.5, Chapter 1, Part 1, Division 3, Title 2 of the Government Code (Government Code, Sections 11135-11139.7)**.

Contractor and its subcontractors shall give written notice of their obligations under this clause to labor organizations with which they have a collective bargaining or other agreement.

The Contractor shall include the nondiscrimination and compliance provisions of this clause in all subcontracts to perform work under the contract.

---

**(Name and Title of Signer)**

---

**Signature**

**Date**

**Company Name** \_\_\_\_\_

**Business Address** \_\_\_\_\_

\_\_\_\_\_

# **CONTRACTOR'S LABOR CODE CERTIFICATION**

**(Labor Code Section 3700 et seq.)**

## **ELECTION EMERGENCY STANDBY GENERATORS INSTALLATION PROJECT**

I am aware of the provisions of Section 3700 and following of the Labor Code which requires every employer to be insured against liability for workers' compensation or to undertake self-insurance in accordance with the provisions of that code, and I will comply with such provisions before commencing the performance of the work of this contract.

---

**(Name and Title of Signer)**

---

**Signature**

---

**Date**

**Company Name**

**Business Address**



**CONTRACTOR AND SUBCONTRACTOR  
REGISTRATION**

**With  
CA Department of Industrial Relations (DIR)  
(CALABOR CODE SECTION 1725.5)**

Bidder hereby certifies that they, and all subcontractors listed on the submitted Bid Form documents, are Registered with the CA Department of Industrial Relations pursuant to requirements of CA Labor Code Section 1725.5 and will comply with all requirements as noted in the aforementioned CA Labor Code Section.

\_\_\_\_\_  
Signed Name

\_\_\_\_\_  
Date

\_\_\_\_\_  
Printed Name

\_\_\_\_\_  
CA DIR Registration No.

# NON-COLLUSION AFFIDAVIT

(Public Contract Code Section 7106)  
(Code of Civil Procedure Section 2015.5)

## ELECTION EMERGENCY STANDBY GENERATORS INSTALLATION PROJECT

The undersigned declares:

I am the \_\_\_\_\_ of \_\_\_\_\_, the party making the foregoing bid. The bid is not made in the interest of, or on behalf of, any undisclosed person, partnership, company, association, organization, or corporation. The bid is genuine and not collusive or sham. The bidder has not directly or indirectly induced or solicited any other bidder to put in a false or sham bid. The bidder has not directly or indirectly colluded, conspired, connived, or agreed with any bidder or anyone else to put in a sham bid, or to refrain from bidding. The bidder has not in any manner, directly or indirectly, sought by agreement, communication, or conference with anyone to fix the bid price of the bidder or any other bidder, or to fix any overhead, profit, or cost element of the bid price, or of that of any other bidder. All statements contained in the bid are true. The bidder has not, directly or indirectly, submitted his or her bid price or any breakdown thereof, or the contents thereof, or divulged information or data relative thereto, to any corporation, partnership, company, association, organization, bid depository, or to any member or agent thereof, to effectuate a collusive or sham bid, and has not paid, and will not pay, any person or entity for such purpose. Any person executing this declaration on behalf of a bidder that is a corporation, partnership, joint venture, limited liability company, limited liability partnership, or any other entity, hereby represents that he or she has full power to execute, and does execute, this declaration on behalf of the bidder.

I declare under penalty of perjury under the laws of the State of California that the foregoing is true and correct and that this declaration is executed on

\_\_\_\_\_, at \_\_\_\_\_, \_\_\_\_\_  
(Date) (City) (State)

\_\_\_\_\_  
(Name and Title of Signer)

\_\_\_\_\_  
Signature

\_\_\_\_\_  
Date

Company Name \_\_\_\_\_

Business Address \_\_\_\_\_  
\_\_\_\_\_

**PUBLIC CONTRACT CODE SECTION 10162  
QUESTIONNAIRE**

**ELECTION EMERGENCY STANDBY GENERATORS INSTALLATION PROJECT**

In accordance with Public Contract Code Section 10162, the Bidder shall complete, under penalty of perjury, the following questionnaire:

Has the Bidder, any officer of the Bidder, or any employee of the Bidder who has a proprietary interest in the Bidder, ever been disqualified, removed, or otherwise prevented from bidding on, or completing a federal, state, or local government project because of a violation of law or a safety regulation:

Yes \_\_\_\_\_ No \_\_\_\_\_

If the answer is yes, explain the circumstances in the following space.

By bidder's signature on the Bid Proposal Form, Bidder certifies, under penalty of perjury under the laws of the State of California, that the foregoing statements in accordance with Public Contract Code Section 10162 are true and correct.

# **PUBLIC CONTRACT CODE STATEMENT (SECTION 10232)**

## **ELECTION EMERGENCY STANDBY GENERATORS INSTALLATION PROJECT**

In accordance with **Public Contract Code Section 10232**, the Contractor hereby states under penalty of perjury, that no more than one final unappealable finding of contempt of court by a federal court has been issued against the Contractor within the immediately preceding two year period because of the Contractor's failure to comply with an order of a federal court which orders the Contractor to comply with an order of the National Labor Relations Board.

By Bidder's signature on the Bid Proposal Form, Bidder certifies, under penalty of perjury under the laws of the State of California, that the foregoing statements in accordance with **Public Contract Code Section 10232** are true and correct.

\_\_\_\_\_  
**(Name and Title of Signer)**

\_\_\_\_\_  
**Signature**

\_\_\_\_\_  
**Date**

**Company Name** \_\_\_\_\_

**Business Address** \_\_\_\_\_

\_\_\_\_\_

# LOCAL BUSINESS PREFERENCES

## INYO COUNTY ORDINANCE No. 1156

### ELECTION EMERGENCY STANDBY GENERATORS INSTALLATION PROJECT

ORDINANCE NO. 1156

**AN ORDINANCE OF THE BOARD OF SUPERVISORS OF THE COUNTY OF INYO, STATE OF CALIFORNIA, ADDING CHAPTER 6.06 TO THE INYO COUNTY CODE TO PROVIDE CONTRACTING PREFERENCES FOR LOCAL AND SMALL BUSINESSES**

The Board of Supervisors of the County of Inyo ordains as follows:

**SECTION 1. PURPOSE AND AUTHORITY**

The purpose of this ordinance is to contribute to the economic and social well-being of all the citizens of the County by providing a contracting preference for local and small businesses. As a market participant, and pursuant to Public Contract Code § 2002, the County may award a purchasing preference to certain entities to vindicate the governmental purpose of encouraging County and regional economic development.

**SECTION 2. ADDITION OF CHAPTER 6.06 TO INYO COUNTY CODE.**

Chapter 6.06 is added to the Inyo County Code to read as follows:

**Chapter 6.06**

**CONTRACTING PREFERENCES**

**Sections:**

- 6.06.010 Findings.**
- 6.06.020 Definitions.**
- 6.06.030 General Provisions.**
- 6.06.040 Local Business and Small Business Preference.**
- 6.06.050 Small Business Subcontracting Preference.**
- 6.06.060 Limit On Contracting Preference.**

**6.06.010 Findings**

Businesses located in Inyo County contribute to the economic and social well-being of all the citizens of the County. Such businesses provide convenient services within the County and provide employment for County citizens. Further, the payroll paid by and income earned by local businesses tend to be largely expended within the County, which enhances the business environment in the County and the well-being of its citizens. It is in the public interest to encourage a vibrant business environment in the County. Providing modest purchasing preferences for County businesses furthers the goal of building a healthy economy in the County. Further, providing contracting preferences for all small businesses is allowed by State law, expands the types of contracts for which preferences may be given, and benefits local small businesses, also furthering the goal of building and maintaining a healthy local economy.

**6.06.020 Definitions.**

- A. A **Small Business** is a business which is certified by the State of California or the Small Business Administration as a small business.
- B. A **Local Business** is a business which:
  - 1. Has its headquarters, distribution point or locally-owned franchise located in or having a street address within the County for at least six months immediately prior to the issuance of the request for competitive bids by the County; and
  - 2. Holds any required business license by a jurisdiction located in Inyo County; and
  - 3. Employs at least one full-time or two part-time employees whose primary residence is located within Inyo County, or if the business has no employees, shall be at least fifty percent owned by one or more persons whose primary residence is located within Inyo County.

4. Meets the conditions of one through three of this subsection, but within Mono or Inyo and Mono Counties, if no Inyo County local business submits a bid that is within eight percent of the lowest bid submitted.

C. A **Responsive Bid** is a bid which responds to the requirements of the request for bids and is submitted by a responsible bidder.

**6.06.030 General Provisions.**

A. The preferences provided in this chapter are intended to extend to the limit of the jurisdiction of Inyo County under California law. Such preferences do not apply where prohibited by Federal or State law. Such preferences do not apply where funding agencies prohibit such preferences as a condition of providing funding for the anticipated project. Where this Chapter provides preferences for multiple classes of entities, and one or more of those classes of entities are disallowed contracting preference by Federal or State law or by the funding agency, those disallowed entities will not be provided preferences, but the remaining classes of entities shall receive preferences.

B. Requests for bids or proposals issued by the County shall specify the applicable contracting preferences available pursuant to this Chapter.

**6.06.040 Local Business and Small Business Preference.**

Except as excluded by Section 6.06.030(A), for all contracts awarded by Inyo County, if the lowest responsive bid is submitted by a local business or a small business, that business shall be awarded the contract. If the lowest responsive bid is not submitted by a local business or a small business, the lowest responsive bid submitted by a local business that is within eight percent of the lowest responsive bid or by a small business that is within five percent of the lowest responsive bid shall be considered the low bid and that business shall be awarded the contract. To be eligible, a local business or a small business shall provide certification with its bid that it is such business as herein defined.

**6.06.050 Small Business Subcontracting Preference.**

For public works and road construction contracts awarded by Inyo County, where no entity qualifying under this Chapter for a contracting preference submits a responsive bid that is the lowest or within five percent of the lowest responsive bid, there shall be a preference given to bids in which at least ten percent of the monetary value of the work to be performed is subcontracted to a small business or businesses. If such bid is the lowest responsive bid, that contractor shall be awarded the contract. If such bid is not the lowest responsive bid, any such bid that is within five percent of the lowest responsive bid shall be considered the low bid, and that contractor shall be awarded the contract.

**6.06.060 Limit On Contracting Preferences.**

Contracting preferences under this Chapter shall not exceed \$10,000.00 for any one solicitation and award determination.

**SECTION 3. SEVERABILITY**

If any section, subsection, sentence, clause or phrase of this ordinance is for any reason held to be unconstitutional or invalid, such decision shall not affect the validity of the remaining portions of this ordinance. The Board of Supervisors hereby declares that it would have passed this ordinance and every section, subsection, sentence, clause or phrase not declared invalid or unconstitutional, without regard to whether any portion of this ordinance would be subsequently declared unconstitutional or invalid.

**SECTION 4. EFFECTIVE DATE**

This Ordinance shall take effect and be in full force and effect thirty (30) days after its adoption. Before the expiration of fifteen (15) days from the adoption hereof, this Ordinance shall be published as required by Government Code Section 25124. The Clerk of the Board is hereby instructed and ordered to so publish this Ordinance together with the names of the Board members voting for and against the same.

**PASSED AND ADOPTED** this 25th day of May, 2010, by the following vote:

AYES: Supervisors Arcularius, Cash, Brown, Fortney and Cervantes  
NOES: -0-  
ABSTAIN: -0-  
ABSENT: -0-

  
Richard Cervantes, Chairperson  
Inyo County Board of Supervisors

ATTEST: Kevin Carunchio  
Clerk of the Board

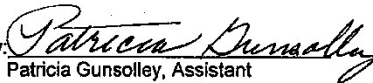
By:   
Patricia Gunsolley, Assistant

s/Ordinance/ContractingPrefSmBusiness

4/29/10

# SMALL BUSINESS ENTERPRISE COMMITMENTS

(Construction Contracts)

**NOTE: PLEASE REFER TO INSTRUCTIONS ON THE REVERSE SIDE/NEXT PAGE OF THIS FORM**

Department: Inyo County Public Works Department LOCATION: Independence, CA

PROJECT DESCRIPTION: ELECTION EMERGENCY STANDBY GENERATORS INSTALLATION PROJECT

TOTAL CONTRACT AMOUNT: \$ \_\_\_\_\_

BID OPENING DATE: December 2nd, 2020

BIDDER'S COMPANY NAME: \_\_\_\_\_

BID ITEM NO.	ITEM OF WORK AND DESCRIPTION OR SERVICES TO BE SUBCONTRACTED OR MATERIALS TO BE PROVIDED	LICENSE INFO./CERT. No. of LOCAL AND SMALL BUSINESS ENTERPRISE AND EXPIRATION DATE	NAME AND CONTACT INFORMATION FOR LOCAL AND SMALL BUSINESS ENTERPRISE (Must be certified on the date bids are opened)	DOLLAR AMOUNT LOCAL AND SMALL BUSINESS ENTERPRISE

<p style="text-align: center;"><b>For Inyo County to Complete:</b></p> <p>Project Number: <u>ZP-20-012</u></p> <p>Financing Type: _____</p> <p>Contract Award Date: _____</p> <p>Checked by: _____</p> <p>Print Name _____ Signature _____ Date _____</p>	<p>Total Claimed Participation \$ _____</p> <p style="text-align: right;">_____ %</p>
	<p>_____ Signature of Bidder</p> <p>_____ Date (Area Code) Tel. No.</p> <p>_____ Person to Contact (Please Type or Print)</p> <p style="text-align: center; font-size: small;">Small Business Enterprise (Rev 5/10)</p>



## ALL BIDDERS:

**PLEASE NOTE: It is the bidder’s responsibility to verify that the Small Business Enterprise (SBE) subcontractors are certified by the proper certifying authorities, and submit evidence of that certification with the bid. If a SBE prime contractor is not certified on the date of the bid opening, the SBE prime contractor will not qualify for the contracting preference. If the SBE subcontractor or subcontractors are not certified on the date of bid opening, that portion of that firm’s participation will not count toward the minimum ten percent of the monetary value of the work needed to qualify for the contracting preference.**

The form requires specific information regarding the construction contract: Total Contract Amount, Bid Opening Date, and Bidder’s Name.

Indicate the appropriate bid item number (or numbers); Item of Work and description or services to be subcontracted or materials to be provided by the SBE; the SBE’s business license information/expiration date, certification number and its expiration date; the SBE’s contact information, including company and contact name, address, and telephone number; and the dollar amount expected to be paid to the SBE.

**IMPORTANT:** Identify **all** SBE firms participating in the project regardless of tier, including the prime contractor, if an SBE. Names of the First Tier SBE Subcontractors and their respective item(s) of work listed should be consistent, where applicable, with the names and items of work in the "List of Subcontractors" submitted with your bid. **Provide copies of the SBEs’ quotes, and if applicable, a copy of joint venture agreements pursuant to the Subcontractors Listing Law and the Special Provisions.**

There is a column for the total SBE dollar amount. Enter the Total Claimed SBE Participation dollars and percentage amount of items of work submitted with your bid pursuant to the special provisions. (If 100% of item is not to be performed or furnished by the SBE, describe exact portion of time to be performed or furnished by the SBE.)

This form must be submitted with the bid if the bidder is attempting to qualify for the SBE contracting preference. If the bidder is not attempting to qualify for the SBE contracting preference the form does not need to be submitted.

# FINAL REPORT – UTILIZATION OF SMALL BUSINESS ENTERPRISES (SBE), FIRST-TIER SUBCONTRACTORS

PROJECT: ELECTION EMERGENCY STANDBY GENERATORS INSTALLATION PROJECT				CONTRACT COMPLETION DATE			
PRIME CONTRACTOR		BUSINESS ADDRESS		ESTIMATED CONTRACT AMOUNT			
BID ITEM NO.	SUBCONTRACTOR NAME, BUSINESS ADDRESS, AND PHONE	DESCRIPTION OF WORK PERFORMED	SBE CERT. NUMBER	CONTRACT PAYMENTS		DATE WORK COMPLETE	DATE OF FINAL PAYMENT
				NON-SBE	SBE		
				\$	\$		
				\$	\$		
				\$	\$		
				\$	\$		
				\$	\$		
				\$	\$		
				\$	\$		
				\$	\$		
			TOTAL	\$	\$		
\$ _____		(i) Original Commitment					
2) I CERTIFY THAT THE ABOVE INFORMATION IS COMPLETE AND CORRECT							
CONTRACTOR REPRESENTATIVES SIGNATURE				BUSINESS PHONE NUMBER		DATE	
4) TO THE BEST OF MY KNOWLEDGE, THE ABOVE INFORMATION IS COMPLETE AND CORRECT							
RESIDENT ENGINEER'S SIGNATURE				BUSINESS PHONE NUMBER		DATE	
To be completed by the contractor and submitted to the Resident Engineer upon project completion							

**INSTRUCTIONS - FINAL REPORT – UTILIZATION OF SMALL BUSINESS ENTERPRISES (SBE), FIRST-TIER SUBCONTRACTORS**

The form requires specific information regarding the construction project, including the prime contractor name and address, contract completion date, and estimated contract amount. The objective of the form is to describe who did what by bid item numbers and description, asking for specific dollar values of item work completed broken down by subcontractors who performed the work, SBE and non-SBE work forces. SBE prime contractors are required to show the date of work performed by their own forces along with the corresponding dollar value of work.

Indicate appropriate bid item number or numbers, a description of work performed or materials provided, and subcontractor name and address. For those firms who are SBE, enter the SBE certification number. The SBE shall provide their certification number to the contractor and notify the contractor in writing with the date of decertification if their status changes during the course of the project.

The form has two columns for the dollar value to be entered for the item work performed by the subcontractor. The non-SBE column is used to enter the dollar value of work performed by firms who are not certified SBEs. Enter the dollar value of work performed by firms who are SBEs in the SBE column.

If the prime contractor or a subcontractor performing work as a SBE on the project becomes decertified and still performs work after their decertification date, enter the total value performed by the contractor/subcontractor under the appropriate SBE identification column.

If the prime contractor or a subcontractor performing work as a non-SBE on the project becomes certified as a SBE, enter the dollar value of all work performed after certification as a SBE under the appropriate SBE identification column.

Enter the total of each column on the form.

[PAGE INTENTIONALLY LEFT BLANK]

# **CONTRACT AND BOND FORMS**

**For**

**ELECTION EMERGENCY STANDBY GENERATORS  
INSTALLATION PROJECT**

**Independence, CA**

**ENCLOSURES:**

Contract: Inyo County Standard Contract  
Faithful Performance Bond  
Labor and Material Payment Bond

[PAGE INTENTIONALLY LEFT BLANK]

**CONTRACT  
BY AND BETWEEN  
THE COUNTY OF INYO  
and**

\_\_\_\_\_, **CONTRACTOR**

**for the**

\_\_\_\_\_ **PROJECT**

THIS CONTRACT is awarded by the COUNTY OF INYO to CONTRACTOR on and made and entered into effective, \_\_\_\_\_, 20\_\_\_\_, by and between the COUNTY OF INYO, a political subdivision of the State of California, (hereinafter referred to as "COUNTY"), and \_\_\_\_\_ (hereinafter referred to as "CONTRACTOR"), for the construction or removal of \_\_\_\_\_ **PROJECT** (hereinafter referred to as "PROJECT"), which parties agree, for and in consideration of the mutual promises, as follows:

**1. SERVICES TO BE PERFORMED.** CONTRACTOR shall furnish, at his/her own expense, all labor, materials, methods, processes, implements, tools, machinery, equipment, transportation, permits, services, utilities, and all other items, and related functions and otherwise shall perform all work necessary or appurtenant to construct the Project in accordance with the Special Provisions, which are incorporated herein by reference per section 4(c) of this Contract, within the Time for Completion set forth, as well as in all other in the Contract Documents, for:

Title: \_\_\_\_\_ **PROJECT**

**2. TIME OF COMPLETION.** Project work shall begin within \_\_\_\_\_ calendar days after receipt of the Notice to Proceed (NTP) (or on the start of work date identified in the NTP) and shall continue until all requested services are completed. Said services shall be completed no later than the Time of Completion as noted in the Project's Special Provisions. Procedures for any extension of time shall be complied with as noted in the Project's Special Provisions.

**3. PAYMENT/CONSIDERATION.** For the performance of all such work, COUNTY shall pay to CONTRACTOR for said work the total amount of: \_\_\_\_\_ dollars (\$\_\_\_\_\_), adjusted by such increases or decreases as authorized in accordance with the Contract Documents, and payable at such times and upon such conditions as otherwise set forth in the Contract Documents.

**4. ALL PROVISIONS SET FORTH HEREIN.** CONTRACTOR and COUNTY agree that this Contract shall include and consist of:

- a. All of the provisions set forth expressly herein;
- b. The Bid Proposal Form, the Faithful Performance Bond, and the Labor and Materials Payment Bond, all of which are incorporated herein and made a part hereof by this reference; and

c. All of the other Contract Documents, as described in **Section 5-1.02, "Definitions,"** of the Standard Specifications of the Inyo County Public Works Department, dated October, 2015, all of which are incorporated herein and made a part of this Contract by this reference, including without limitation, the Bid Package, the Standard Specifications of the Inyo County Public Works Department, dated October, 2015, and the Special Provisions concerning this Project including the Appendices, the Plans, any and all amendments or changes to any of the above-listed documents, including, without limitation, contract change orders, and any and all documents incorporated by reference into any of the above-listed documents.

**5. STANDARD OF PERFORMANCE.** Contractor represents that he/she is qualified and licensed to perform the work to be done as required in this Contract. County relies upon the representations of Contractor regarding professional and/or trade training, licensing, and ability to perform the services as a material inducement to enter into this Contract. Acceptance of work by the County does not operate to release Contractor from any responsibility to perform work to professional and/or trade standards. Contractor shall provide properly skilled professional and technical personnel to perform all services under this Contract. Contractor shall perform all services required by this Contract in a manner and according to the standards observed by a competent practitioner of the profession. All work products of whatsoever nature delivered to the County shall be prepared in a manner conforming to the standards of quality normally observed by a person practicing in Contractor's profession and/or trade.

**6. INDEPENDENT CONTRACTOR.** Nothing contained herein or any document executed in connection herewith, shall be construed to create an employer-employee, partnership or joint venture relationship between County and Contractor, nor to allow County to exercise discretion or control over the manner in which Contractor performs the work or services that are the subject matter of this Contract; provided, however, the work or services to be provided by Contractor shall be provided in a manner consistent with reaching the County's objectives in entering this Contract.

Contractor is an independent contractor, not an employee of County or any of its subsidiaries or affiliates. Contractor will not represent him/herself to be nor hold her/himself out as an employee of County. Contractor acknowledges that s/he shall not have the right or entitlement in or to any of the pension, retirement or other benefit programs now or hereafter available to County's employees. The consideration set forth in Paragraph 3 shall be the sole consideration due Contractor for the services rendered hereunder. It is understood that County will not withhold any amounts for payment of taxes from the Contractor's compensation hereunder. Any and all sums due under any applicable state, federal or municipal law or union or professional and/or trade guild regulations shall be Contractor's sole responsibility. Contractor shall indemnify and hold County harmless from any and all damages, claims and expenses arising out of or resulting from any claims asserted by any third party, including but not limited to a taxing authority, as a result of or in connection with payments due it from Contractor's compensation.

**7. ASSIGNMENT AND SUBCONTRACTING.** The parties recognize that a substantial inducement to County for entering into this Contract is the professional reputation, experience and competence of Contractor. Assignments of any and/or all rights, duties or obligations of the Contractor under this Contract will be permitted only with the express consent



of the County. Contractor shall not subcontract any portion of the work to be performed under this Contract without the written authorization of the County. If County consents to such subcontract, Contractor shall be fully responsible to County for all acts or omissions of the subcontractor. Nothing in this Contract shall create any contractual relationship between County and subcontractor, nor shall it create any obligation on the part of the County to pay any monies due to any such subcontractor, unless otherwise required by law.

**8. CLAIMS RESOLUTION.** Pursuant to **Section 9204 of the Public Contract Code**, any and all claims submitted by Contractor to County will follow the provisions as set forth in the Project's Special Provisions.

**9. INSURANCE INDEMNIFICATION.** Contractor shall hold harmless, defend and indemnify County and its officers, officials, employees and volunteers from and against all claims, damages, losses, and expenses, including attorney fees arising out of the performance of the work described herein, caused in whole or in part by any negligent act or omission of the Contractor, any subcontractor, anyone directly or indirectly employed by any of them, or anyone for whose acts any of them may be liable, except where caused by the active negligence, sole negligence, or willful misconduct of the County.

**10. INSURANCE.** For the duration of this Agreement, Contractor shall procure and maintain insurance of the scope and amount specified in Attachment 3 and with the provisions specified in that attachment.

**11. POLITICAL REFORM ACT.** Contractor is not a designated employee within the meaning of the Political Reform Act because Contractor:

- a. Will conduct research and arrive at conclusions with respect to his/her rendition of information, advice, recommendation or counsel independent of the control and direction of the County or of any County official, other than normal Contract monitoring; and
- b. Possesses no authority with respect to any County decision beyond rendition of information, advice, recommendation or counsel [FPPC Reg. 18700(a)(2)].

**12. COMPLIANCE WITH ALL LAWS.**

**Performance Standards:** Contractor shall use the standard of care in its profession and/or trade to comply with all applicable federal, state and local laws, codes, ordinances and regulations that relate to the work or services to be provided pursuant to this Contract.

a. Safety Training:

i. Contractor shall provide such safety and other training as needed to assure work will be performed in a safe and healthful manner "in a language" that is understandable to employees receiving the training. The training shall in all respects be in compliance with CAL OSHA; and

ii. Contractor working with employees shall maintain a written Injury and Illness Prevention (IIP) Program, a copy of which must be maintained at each worksite or at a central worksite identified for the employees, if the Contractor has non-fixed worksites; and

iii. Contractor using subcontractors with the approval of the County to perform the work which is the subject of this Contract shall require each subcontractor working with employees to comply with the requirements of this section.

b. Child, Family and Spousal Support reporting Obligations:

i. Contractor shall comply with the state and federal child, family and spousal support reporting requirements and with all lawfully served wage and earnings assignment orders or notices of assignment relating to child, family and spousal support obligations.

c. Nondiscrimination:

i. Contractor shall not discriminate in employment practices or in the delivery of services on the basis of membership in a protected class which includes any class recognized by law and not limited to race, color, religion, sex (gender), sexual orientation, marital status, national origin (Including language use restrictions), ancestry, disability (mental and physical, including HIV and Aids), medical Conditions (cancer/genetic characteristics), age (40 and above) and request for family care leave.

ii. Contractor represents that it is in compliance with federal and state laws prohibiting discrimination in employment and agrees to stay in compliance with the Americans with Disabilities Act of 1990 (42 U.S.C. sections 12101, et. seq.), Age Discrimination in Employment Act of 1975 (42 U.S.C. 5101, et. seq.), Title VII (42 U.S.C. 2000, et. seq.), the California Fair Employment Housing Act (California Government Code sections 12900, et. seq.) and regulations and guidelines issued pursuant thereto.

**13. LICENSES.** Contractor represents and warrants to County that it has all licenses, permits, qualifications, insurance and approvals of whatsoever nature which are legally required of Contractor to practice its trade and/or profession. Contractor represents and warrants to County that Contractor shall, at its sole cost and expense, keep in effect or obtain at all times during the term of this Contract, any licenses, permits, insurance and approvals which are legally required of Contractor to practice its and/or profession.

**14. PREVAILING WAGE.** Pursuant to **Section 1720 et seq. of the Labor Code**, Contractor agrees to comply with the Department of Industrial Relations regulations, to which this Contract is subject, the prevailing wage per diem rates in Inyo County have been determined by the Director of the State Department of Industrial Relations. These wage rates appear in the Department publication entitled "General Prevailing Wage Rates," in effect at the time the project is advertised. Future effective wage rates, which have been predetermined and are on file with the State Department of Industrial Relations are referenced but not printed in said publication. Such rates of wages are also on file with the State Department of Industrial Relations and the offices of the Public Works Department of the County of Inyo and are available to any interested party upon request. Contractor agrees to comply with County and the Department of Industrial Relations regulations in submitting the certified payroll.

**15. CONTROLLING LAW VENUE.** This Contract is made in the County of Inyo, State of California. The parties specifically agree to submit to the jurisdiction of the Superior Court of California for the County of Inyo.

**16. WRITTEN NOTIFICATION.** Any notice, demand, request, consent, approval or communication that either party desires or is required to give to the other party shall be in writing and either served personally or sent prepaid, first class mail. Any such notice, demand, et cetera, shall be addressed to the other party at the address set forth herein below. Either party

may change its address by notifying the other party of the change of address. Notice shall be deemed communicated within 48 hours from the time of mailing if mailed as provided in this section.

If to County: County of Inyo  
Public Works Department  
Attn: \_\_\_\_\_  
168 N. Edwards  
PO Drawer Q  
Independence, CA 93526

If to Contractor: \_\_\_\_\_  
\_\_\_\_\_  
\_\_\_\_\_  
\_\_\_\_\_

**17. AMENDMENTS.** This Contract may be modified or amended only by a written document executed by both Contractor and County and approved as to form by Inyo County Counsel.

**18. WAIVER.** No failure on the part of either party to exercise any right or remedy hereunder shall operate as a waiver of any other right or remedy that party may have hereunder.

**19. TERMINATION.** This Contract may be terminated for the reasons stated below:

- a. Immediately for cause, if either party fails to perform its responsibilities under this Contract in a timely and professional manner and to the satisfaction of the other party or violates any of the terms or provisions of this Contract. If termination for cause is given by either party to the other and it is later determined that the other party was not in default or default was excusable, then the notice of termination shall be deemed to have been given without cause pursuant to paragraph “b” of this section; or
- b. By either party without cause upon fifteen (15) days' written notice of termination. Upon termination, Contractor shall be entitled to compensation for services performed up to the effective date of termination; or
- c. By County upon oral notice from the Board of Supervisors based on funding ending or being materially decreased during the term of this Contract.

**20. TIME IS OF THE ESSENCE.** Time is of the essence for every provision.

**21. SEVERABILITY.** If any provision of this Contract is held to be invalid, void or unenforceable, the remainder of the provision and/or provisions shall remain in full force and effect and shall not be affected, impaired or invalidated.

**22. CONTRACT SUBJECT TO APPROVAL BY BOARD OF SUPERVISORS.** It is understood and agreed by the parties that this Contract is subject to the review and approval by the Inyo County Board of Supervisors upon Notice and Public Hearing. In the event that the Board of Supervisors declines to enter into or approve said Contract, it is hereby agreed to that

there is, in fact, no binding agreement, either written or oral, between the parties herein.

**23. ATTACHMENTS.** All attachments referred to are incorporated herein and made a part of this Contract.

**24. EXECUTION.** This Contract may be executed in several counterparts, each of which shall constitute one and the same instrument and shall become binding upon the parties. In approving this Contract, it shall not be necessary to produce or account for more than one such counterpart.

**25. ENTIRE AGREEMENT.** This Contract, including the Contract Documents and all other documents which are incorporated herein by reference, constitutes the complete and exclusive agreement between the County and Contractor. All prior written and oral communications, including correspondence, drafts, memoranda, and representations, are superseded in total by this Contract.

---o0o---

IN WITNESS WHEREOF, COUNTY and CONTRACTOR have each caused this Contract to be executed on its behalf by its duly authorized representative, effective as of the day and year first above written.

**COUNTY**

**CONTRACTOR**

COUNTY OF INYO

\_\_\_\_\_

By: \_\_\_\_\_

By: \_\_\_\_\_

Name: \_\_\_\_\_

Name: \_\_\_\_\_

Title: \_\_\_\_\_

Title: \_\_\_\_\_

Dated: \_\_\_\_\_

Dated: \_\_\_\_\_

APPROVED AS TO FORM AND LEGALITY:

\_\_\_\_\_  
County Counsel

APPROVED AS TO ACCOUNTING FORM:

\_\_\_\_\_  
County Auditor

APPROVED AS TO INSURANCE REQUIREMENTS:

\_\_\_\_\_  
County Risk Manager

ATTACHMENT 1

PROJECT

FAITHFUL PERFORMANCE BOND
(100% OF CONTRACT AMOUNT)

KNOW ALL MEN BY THESE PRESENTS: That

(Name of Contractor) as Principal, hereinafter "Contractor,"

and (Name of Corporate Surety)

as Corporate Surety, hereinafter called Surety, are held and firmly bound unto the County of Inyo as Obligee, hereinafter called County, in the amount of dollars (\$ . ), for the payment whereof Contractor and Surety bind themselves, their heirs, executors, administrators, successors and assignees, jointly and severally, firmly by these presents.

WHEREAS, Contractor has, by written Contract, dated , 20 , entered into an Contract with the County for the Construction of the PROJECT (hereinafter referred to as "Project"), to be constructed in accordance with the terms and conditions set forth in the Contract for the Project, which contract is by reference incorporated herein and is hereinafter referred to as the "Contract."

NOW, THEREFORE, THE CONDITION OF THIS OBLIGATION is such that, if Contractor shall promptly and faithfully perform said Contract, then this obligation shall be null and void; otherwise it shall remain in full force and effect.

The Surety hereby waives notice of any alteration or extension of time made by the County.

Whenever Contractor shall be, and is declared by County to be, in default under the Contract, the County having performed Owner's obligations thereunder, the Surety may promptly remedy the default, or shall promptly either:

- 1. Complete the Contract in accordance with its terms and conditions; or,
2. Obtain a Bid or Bids for completing the Contract in accordance with its terms and conditions, and upon determination by Surety of the lowest responsible Bidder, or if the County elects, upon determination by the County and the Surety jointly of the lowest responsible Bidder, arrange for a Contract between such Bidder and County, and make available as work progresses (even though there should be a default or a succession of defaults under the Contract or contracts of completion arranged under this paragraph) sufficient funds to pay the cost of completion less the balance of the Contract price; but not exceeding, including other costs and damages for which the Surety may be liable hereunder, the amount set forth in the first paragraph hereof. The

term "balance of the Contract price", as used in this paragraph, shall mean the total amount payable by County to Contractor under the Contract and any amendments thereto, less the amount properly paid by County to Contractor.

Any suit under this Bond must be instituted before the expiration of two (2) years from the date on which final payment under the Contract falls due, or the date on which any warranty or guarantee period expires, whichever is later.

No right of action shall accrue on this Bond to or for the use of any person or corporation other than the County named herein.

---o0o---

Signed and sealed this \_\_\_\_\_ day of \_\_\_\_\_, 20 \_\_\_\_.

\_\_\_\_\_  
(Name of Corporate Surety)

By: \_\_\_\_\_  
(Signature)

(SEAL)

\_\_\_\_\_  
(Title of Authorized Person)

\_\_\_\_\_  
(Address for Notices to be Sent)

\_\_\_\_\_  
(Name of Contractor)

By: \_\_\_\_\_  
(Signature)

(SEAL)

\_\_\_\_\_  
(Title of Authorized Person)

\_\_\_\_\_  
(Address for Notices to be Sent)

**NOTE: THE SIGNATURES OF THE CONTRACTOR AND THE SURETY MUST EACH BE ACKNOWLEDGED BEFORE A NOTARY PUBLIC (OR OTHER OFFICER AUTHORIZED UNDER CALIFORNIA LAW) AND THE ACKNOWLEDGMENTS MUST BE ATTACHED TO THIS BOND.**

The Faithful Performance Bond must be executed by a corporate surety on this form. No substitutions will be accepted. If an attorney-in-fact signs for the surety, an acknowledged statement from the surety appointing and empowering the attorney-in-fact to execute such bonds in such amounts on behalf of the surety must accompany the Faithful Performance Bond.

**ADDRESS OF COUNTY FOR NOTICES TO BE SENT:**

County of Inyo  
224 North Edwards Street, P.O. Box N  
Independence, California 93526

ATTACHMENT 2

PROJECT

LABOR AND MATERIALS PAYMENT BOND
(100% OF CONTRACT AMOUNT)

KNOW ALL MEN BY THESE PRESENTS, that (Name of Contractor)

as Principal, hereinafter "CONTRACTOR,"

and (Name of Corporate Surety)

as Corporate Surety, hereinafter called SURETY, are held and firmly bound unto the County of Inyo as Obligee, hereinafter called COUNTY, for the use and benefit of claimants as hereinafter defined in the amount of dollars (\$ ) for the payment whereof Contractor and Surety bind themselves, their heirs, executors, administrators, successors and assignees, jointly and severally, firmly by these presents.

WHEREAS, Contractor has by written contract dated , 20 , entered into an Contract with the County for the construction of the PROJECT (hereinafter referred to as "PROJECT"), to be constructed in accordance with the terms and conditions set forth in the contract for the PROJECT, which contract is by reference incorporated herein, and is hereinafter referred to as the "CONTRACT."

NOW, THEREFORE, THE CONDITION OF THIS OBLIGATION is such that, if Contractor shall promptly make payment to all claimants as hereinafter defined, for all labor and materials used or reasonably required for use in the performance of the Contract, then this obligation shall be void; otherwise, it shall remain in full force and effect, subject, however, to the following conditions:

- 1. A claimant is defined as one having a direct contract with the Contractor, or with a Subcontractor of the Contractor, for labor, materials, or both, used or reasonably required for use in the performance of the Contract. Labor and materials is construed to include, but not limited to, that part of water, gas, power, light, heat, oil, gasoline, telephone service or rental of equipment directly applicable to the Contract.
2. The above named Contractor and Surety hereby jointly agree with the County that every claimant as herein defined, who has not been paid in full before the expiration of a period of ninety (90) calendar days after the date on which the last of such claimant's work or labor was done or performed, or materials were furnished by such claimant, may sue on this Bond for the benefit of such claimant, prosecute the suit to final judgment for such



sum or sums as may be justly due claimant, and have execution thereon. The County shall not be liable for the payment of any costs or expenses of any such suit.

3. No suit or action shall be commenced hereunder by any claimant:

a) Unless claimant, other than one having a direct contract with the Contractor, shall have given written notice to any two of the following: the Contractor, the County, or the Surety above named, within ninety (90) calendar days after such claimant did or performed the last of the work or labor, or furnished the last of the material for which said claim is made, stating with substantial accuracy the amount claimed and the name of the party to whom the materials were furnished, or for whom the work or labor was done or performed. Such notice shall be served by mailing the same by registered mail or certified mail, postage prepaid, in any envelope addressed to the Contractor, County, or Surety, at the address below, or at any place where an office is regularly maintained for the transaction of their business. Such notice may also be served in the state in which the aforesaid project is located, save that such service need not be made by a public officer.

b) After the expiration of one (1) year following the date on which County accepted the work done under the Contract. However, if any limitation embodied in this Bond is prohibited by any law controlling the construction hereof, such limitation shall be deemed to be amended so as to be equal to the minimum period of limitation permitted by such law.

c) Other than in a State Court of competent jurisdiction in and for the County or other political subdivision of the state in which the Project, or any part thereof, is situated, and not elsewhere.

4. The amount of this Bond shall be reduced by and to the extent of any payment or payments made in good faith hereunder, inclusive of the payment by Surety of mechanics' liens which may be filed or recorded against said Project, whether or not claim for the amount of such lien be presented under and against this Bond.

---o0o---

Signed and sealed this \_\_\_\_\_ day of \_\_\_\_\_, 20 \_\_\_\_.

\_\_\_\_\_  
(Name of Contractor)

By: \_\_\_\_\_  
(Signature)

(SEAL)

\_\_\_\_\_  
(Title of Authorized Person)

\_\_\_\_\_  
(Address for Notices to be Sent)

\_\_\_\_\_  
(Name of Corporate Surety)

By: \_\_\_\_\_  
(Signature)

(SEAL)

\_\_\_\_\_  
(Title of Authorized Person)

\_\_\_\_\_  
(Address for Notices to be Sent)

**NOTE:**

**THE SIGNATURES OF THE CONTRACTOR AND THE SURETY MUST BE ACKNOWLEDGED BEFORE A NOTARY PUBLIC (OR OTHER OFFICER AUTHORIZED UNDER CALIFORNIA LAW).**

The Labor and Materials Payment Bond must be executed by a corporate surety on this form. No substitutions will be accepted. If an attorney-in-fact signs for the surety, an acknowledged statement from the surety appointing and empowering the attorney-in-fact to execute such bonds in such amounts on behalf of the surety, must accompany the Labor and Materials Payment Bond.

ADDRESS OF COUNTY FOR NOTICES TO BE SENT TO:

**County of Inyo  
224 N. Edwards, P.O. Box N  
Independence, California 93526**

**ATTACHMENT 3**

**AGREEMENT BETWEEN THE COUNTY OF INYO AND**

**FOR THE \_\_\_\_\_ PROJECT**

**TERM:**

**FROM: \_\_\_\_\_ TO: \_\_\_\_\_**

**SEE ATTACHED INSURANCE PROVISIONS**

## **Specifications 5**

### **Insurance Requirements for Construction Contracts**

Contractor shall procure and maintain for the duration of the contract, insurance against claims for injuries to persons or damages to property which may arise from or in connection with the performance of the work hereunder by the Contractor, his agents, representatives, employees, or subcontractors.

#### **MINIMUM SCOPE AND LIMIT OF INSURANCE**

Coverage shall be at least as broad as:

1. **Commercial General Liability (CGL):** Insurance Services Office Form CG 00 01, including products and completed operations, with limits of no less than **\$1,000,000.00** per occurrence for bodily injury, personal injury, and property damage. If a general aggregate limit applies, either the general aggregate limit shall apply separately to this project/location or the general aggregate limit shall be twice the required occurrence limit.
2. **Automobile Liability:** Insurance Services Office Form Number CA 0001 covering Code 1 (any auto), with limits no less than **\$1,000,000** per accident for bodily injury and property damage.
3. **Workers' Compensation** insurance as required by the State of California, with Statutory Limits, and Employers' Liability insurance with a limit of no less than \$1,000,000 per accident for bodily injury or disease.

#### ***Deductibles and Self-Insured Retentions***

Any deductibles or self-insured retentions must be declared to and approved by the Entity. At the option of the Entity, either: the contractor shall cause the insurer shall reduce or eliminate such deductibles or self-insured retentions as respects the Entity, its officers, officials, employees, and volunteers; or the Contractor shall provide a financial guarantee satisfactory to the Entity guaranteeing payment of losses and related investigations, claim administration, and defense expenses.

#### ***Other Insurance Provisions***

The insurance policies are to contain, or be endorsed to contain, the following provisions:

1. **The Entity, its officers, officials, employees, and volunteers are to be covered as additional insureds** on the CGL and automobile liability policies with respect to liability arising out of with respect to liability arising out of work or operations performed by or on behalf of the Contractor including materials, parts, or equipment furnished in connection with such work or operations and automobiles owned, leased, hired, or borrowed by or on behalf of the Contractor. General liability coverage can be provided in the form of an endorsement to the Contractor's insurance (at least as broad as ISO Form CG 20 10, 11 85 or both CG 20 10 and CG 23 37 forms if later revisions used).
2. For any claims related to this project, the **Contractor's insurance coverage shall be primary** insurance as respects the Entity, its officers, officials, employees, and volunteers. Any insurance or self-insurance maintained by the Entity, its officers, officials, employees, or volunteers shall be excess of the Contractor's insurance and shall not contribute with it.
3. Each insurance policy required by this clause shall provide that coverage shall not be canceled, except with notice to the Entity.

#### ***Builder's Risk (Course of Construction) Insurance***

Contractor may submit evidence of Builder's Risk insurance in the form of Course of Construction coverage. Such coverage shall **name the Entity as a loss payee** as their interest may appear.

If the project does not involve new or major reconstruction, at the option of the Entity, an Installation Floater may be acceptable. For such projects, a Property Installation Floater shall be obtained that provides for the improvement, remodel, modification, alteration, conversion or adjustment to existing buildings, structures, processes, machinery and equipment. The Property Installation Floater shall provide property damage coverage for any building, structure, machinery or equipment damaged, impaired, broken, or destroyed during the performance of the Work, including during transit, installation, and testing at the Entity's site.

#### ***Claims Made Policies***

If any coverage required is written on a claims-made coverage form:

1. The retroactive date must be shown, and this date must be before the execution date of the contract or the beginning of contract work.
2. Insurance must be maintained and evidence of insurance must be provided for at least five (5) years after completion of contract work.
3. If coverage is canceled or non-renewed, and not replaced with another claims-made policy form with a retroactive date prior to the contract effective, or start of work date, the Contractor must purchase extended reporting period coverage for a minimum of five (5) years after completion of contract work.
4. A copy of the claims reporting requirements must be submitted to the Entity for review.
5. If the services involve lead-based paint or asbestos identification/remediation, the Contractors Pollution Liability policy shall not contain lead-based paint or asbestos exclusions. If the services involve mold identification/remediation, the Contractors

Pollution Liability policy shall not contain a mold exclusion, and the definition of Pollution shall include microbial matter, including mold.

### ***Acceptability of Insurers***

Insurance is to be placed with insurers with a current A.M. Best rating of no less than A: VII, unless otherwise acceptable to the Entity.

### ***Waiver of Subrogation***

**Contractor hereby agrees to waive rights of subrogation which any insurer of Contractor may acquire** from Contractor by virtue of the payment of any loss. Contractor agrees to obtain any endorsement that may be necessary to effect this waiver of subrogation. **The Workers' Compensation policy shall be endorsed with a waiver of subrogation** in favor of the Entity for all work performed by the Contractor, its employees, agents and subcontractors.

### ***Verification of Coverage***

Contractor shall furnish the Entity with original certificates and amendatory endorsements, or copies of the applicable insurance language, effecting coverage required by this contract. All certificates and endorsements are to be received and approved by the Entity before work commences. However, failure to obtain the required documents prior to the work beginning shall not waive the Contractor's obligation to provide them. The Entity reserves the right to require complete, certified copies of all required insurance policies, including endorsements, required by these specifications, at any time.

### ***Subcontractors***

Contractor shall require and verify that all subcontractors maintain insurance meeting all the requirements stated herein.

### ***Surety Bonds***

Contractor shall provide the following Surety Bonds:

1. Bid bond
2. Performance bond
3. Payment bond
4. Maintenance bond

The Payment Bond and the Performance Bond shall be in a sum equal to the contract price. If the Performance Bond provides for a one-year warranty a separate Maintenance Bond is not necessary. If the warranty period specified in the contract is for longer than one year a Maintenance Bond equal to 10% of the contract price is required. Bonds shall be duly executed by a responsible corporate surety, authorized to issue such bonds in the State of California and secured through an authorized agent with an office in California.

### ***Special Risks or Circumstances***

Entity reserves the right to modify these requirements, including limits, based on the nature of the risk, prior experience, insurer, coverage, or other circumstances.

# **SPECIAL PROVISIONS**

**FOR**

**ELECTION EMERGENCY STANDBY GENERATORS  
INSTALLATION PROJECT**

**Inyo County, CA**



[PAGE INTENTIONALLY LEFT BLANK]

COUNTY OF INYO  
DEPARTMENT OF PUBLIC WORKS

# SPECIFICATIONS APPROVAL

**ELECTION EMERGENCY STANDBY GENERATORS  
INSTALLATION PROJECT**  
Inyo County, CA

**These Special Provisions have been prepared by the Inyo County Public Works  
Department under the direction of the undersigned and are approved for the work  
contemplated herein.**

**Michael Errante, P.E.** Digitally signed by Michael Errante, P.E.  
Date: 2020.10.22 13:04:53 -07'00'

---

Director of Public Works

10/22/2020  
Specifications Approval Date

[PAGE INTENTIONALLY LEFT BLANK]

## **INTRODUCTION / GENERAL:**

The ELECTION EMERGENCY STANDBY GENERATORS INSTALLATION PROJECT, a public works project of Inyo County, is to be constructed and completed in accordance with these Special Provisions, the Project Plans, and, insofar as they are referenced herein, the Standard Specifications of the Inyo County Public Works Department dated October, 2015 (Standard Specifications). The Special Provisions, the Project Plans, and the sections of the Standard Specifications referenced herein, constitute a portion of the “Contract Documents” governing the project and shall therefore be binding upon and observed by the person/entity with whom the County of Inyo enters into contract for construction of the Project.

Copies of the Project Plans may be obtained from the Inyo County Public Works Department in Independence, California, or online at: [Bid Requests & RFPs](#)

Unless indicated otherwise, all references in this document to sections are to those in the Standard Specifications or to other sections in these Special Provisions. In case of any irreconcilable conflict between the requirements of the Standard Specifications referenced herein and these Special Provisions, the latter shall prevail and be observed.

## **PROJECT DESCRIPTION:**

This Project includes the installation of five generators and five automatic transfer switches, which are furnished by Inyo County Public Works. It also includes all necessary labor, equipment, materials, permits, design & calculations per the attached Scope of Work.

A job walk will be held on **November 10th, 2020, at 10:00 a.m.** starting at the Tri-County Fairgrounds

The work is more particularly described in the Plans and below, in the Project Special Provisions. All of the work shall be in accordance with all applicable State and local laws, codes, and regulations.

## **SECTION 3 CONTRACT AWARD AND EXECUTION**

### **3-1.04 CONTRACT AWARD**

Section 3-1.04 of the Standard Specifications shall be amended as follows:

Whenever possible, the award to the lowest bidder, if made, will be made no later than thirty (30) calendar days after the opening of bid proposals. However, failure of the County to make award within thirty (30) calendar days after the opening of the bid proposals shall not relieve the Contractor of its requirement to deliver an executed contract and bonds, and any other required documents, within 15 days of Notification of Award, as further described in Section 3-1.18: Contract Execution.

### **3-1.05 CONTRACT BONDS (PUB CONT CODE §§ 10221 AND 10222)**

The successful bidder must furnish 2 bonds:

1. Payment bond to secure the claim payments of laborers, workers, mechanics, or materialmen providing goods, labor, or services under the Contract. This bond must be equal to at least 100 percent of the Contract amount.
2. Performance bond to guarantee the faithful performance of the Contract. This bond must be equal to at least 100 percent of the Contract amount.

The bond forms are in the Bid Book.

### **3-1.06 CONTRACTOR LICENSE**

For a federal-aid contract, the Contractor must be properly licensed as a contractor from contract award through Contract acceptance (Pub Cont Code § 10164).

For a non-federal-aid contract:

1. The Contractor must be properly licensed as a contractor from bid opening through Contract acceptance (Bus & Prof Code § 7028.15)
2. Joint venture bidders must obtain a joint venture license before contract award (Bus & Prof Code § 7029.1)

### **3-1.07 INSURANCE POLICIES**

The successful bidder must submit:

1. Copy of its commercial general liability policy and its excess policy or binder until such time as a policy is available, including the declarations page, applicable endorsements, riders, and other modifications in effect at the time of contract execution. Standard ISO form no. CG 0001 or similar exclusions are allowed if not inconsistent with section 7-1.06. Allowance of additional exclusions is at the discretion of the Department.
2. Certificate of insurance showing all other required coverages. Certificates of insurance, as evidence of required insurance for the auto liability and any other required policy, shall set forth deductible amounts applicable to each policy and all exclusions that are added by endorsement to each policy. The evidence of insurance shall provide that no cancellation, lapse, or reduction of coverage will occur without 10 days prior written notice to the Department.
3. A declaration under the penalty of perjury by a CPA certifying the accountant has applied GAAP guidelines confirming the successful bidder has sufficient funds and resources to cover any selfinsured retentions if the self-insured retention is over \$50,000.

If the successful bidder uses any form of self-insurance for workers compensation in lieu of an insurance policy, it shall submit a certificate of consent to self-insure under Labor Code § 3700.

### **3-1.08 SMALL BUSINESS ENTERPRISE PARTICIPATION**

This section is amended as follows.

This project is subject to Inyo County Ordinance No. 1156, *An Ordinance of the Board of Supervisors of the County of Inyo, State of California, Adding Chapter 6.06 to the Inyo County Code to Provide Contacting Preferences for Local and Small Businesses*, which is included in the bid package.

Take necessary and reasonable steps to ensure that small business enterprises (SBEs) have opportunity to participate in the contract.

Make work available to SBEs and select work parts consistent with available SBE subcontractors and suppliers.

To qualify for the SBE contracting preference as described in Inyo County Ordinance No. 1156 (Ordinance No. 1156), Section 6.06.040, the bidder must show that he/she is a SBE as described in Ordinance No. 1156 Section 6.06.020.

To qualify for the SBE subcontracting preference as described in Ordinance No. 1156, Section 6.06.050, the bidder must show that the subcontractor(s) proposed for work on the project is/are a SBE(s) as described in Ordinance No. 1156 Section 6.06.020.

**It is the bidders responsibility to verify that the SBE(s) is certified as a small business enterprise at the date of bid opening.**

#### **SBE Contracting Preference Commitment Submittal**

If the bidder is claiming the SBE contracting preference, submit SBE information on the “Small Business Enterprise Commitment (Construction Contracts),” form included in the Bid Package. If the bidder is not claiming the SBE contracting preference remove the form from the Bid Package before submitting your bid.

Submit written confirmation from each SBE subcontractor stating that it is participating in the contract. Include confirmation with the SBE Commitment form. A copy of a SBE subcontractor’s quote will serve as written confirmation that the SBE is participating in the contract.

**SUBCONTRACTOR AND SBE RECORDS.** The Contractor shall maintain records showing the name and business address of each first-tier subcontractor. The records shall also show the name and business address of every SBE subcontractor, SBE vendor of materials and SBE trucking company, regardless of tier. The records shall show the date of payment and the total dollar figure paid to all of these firms. SBE prime contractors shall also show the date of work performed by their own forces along with the corresponding dollar value of the work.

Upon completion of the contract, a summary of these records shall be prepared on “Final Report – Utilization of Small Business Enterprises - (SBE), First-Tier Subcontractors,” certified correct

by the Contractor or his authorized representative, and submitted to the Engineer. The form shall be furnished to the Engineer within 90 days from the date of contract acceptance.

### **3-1.18 CONTRACT EXECUTION**

The successful bidder must sign the Contract form.

Deliver two (2) fully executed (except for the County's signature) to the Office Engineer:

1. Signed Contract form
2. Contract bonds
3. Documents identified in section 3-1.07
4. Payee Data Record
5. Small Business (SB) Participation Report form
6. For a federal-aid contract, Caltrans Bidder - DBE Information form

The Office Engineer must receive these documents before the 10th business day after the bidder receives the contract.

The bidder's security may be forfeited for failure to execute the contract within the time specified (Pub Cont Code §§ 10181, 10182, and 10183).

A copy of the Contract form is included in your bid book.

## **SECTION 7 LEGAL RELATIONS AND RESPONSIBILITY TO THE PUBLIC**

Amended to read as follows:

### **7-1.02K (2) WAGES**

The general prevailing wage rates, determined by the Department of Industrial Relations, for Inyo County, are available at the County of Inyo address or the California DIR web site at <http://www.dir.ca.gov>. Changes are available at the same locations. These wage rates are not included in the Contract Documents. All labor will be paid at not less than these minimum wage rates.

### **ADD TO 7-1.02K (3) CERTIFIED PAYROLL RECORDS (LABOR CODE §1776)**

Keep accurate payroll records. Submit a copy of your certified payroll records, weekly, including those of subcontractors to the following:

1. Inyo County Department of Public Works
2. Division of Labor Standards Enforcement of the Department of Industrial Relations
3. Division of Apprenticeship Standards of the Department of Industrial Relations

Include:

1. Each employee's:
  - 1.1. Full name
  - 1.2. Address



- 1.3. Social security number
  - 1.4. Work classification
  - 1.5. Straight time and overtime hours worked each day and week
  - 1.6. Actual wages paid for each day to each:
    - 1.6.1. Journeyman
    - 1.6.2. Apprentice
    - 1.6.3. Worker
    - 1.6.4. Other employee you employ for the work
  - 1.7. Pay rate
  - 1.8. Itemized deductions made
  - 1.9. Check number issued
2. Apprentices and the apprentice-to-journeyman ratio

Each certified payroll record must include a Statement of Compliance signed under penalty of perjury that declares:

1. The information contained in the payroll record is true, correct, and complete
2. The employer has complied with the requirements of sections 1771, 1811, and 1815 for any work performed by his or her employees on the public works project
3. The wage rates paid are at least those required by the Contract

#### **7-1.05 INDEMNIFICATION**

Contractor shall hold harmless, defend, and indemnify the County of Inyo and its officers, officials, employees, and volunteers from and against all claims, damages, losses, and expenses including attorney fees and litigation costs, arising out of the performance of the work described herein, caused in whole or in part by any negligent act or omission of the Contractor, any subcontractor, anyone directly or indirectly employed by any of them, or anyone for whose acts any of them may be liable, except where caused by the active negligence, sole negligence, or willful misconduct of the County.

#### **7-1.06 INSURANCE**

**Please see ‘Insurance Requirements for Construction Contracts’**

## **SECTION 8 PROSECUTION AND PROGRESS**

Amended to read as follows:

### **ADD TO 8-1.05 TIME**

The Contractor shall complete all designated portions of the work required to be provided pursuant to the contract no later than **Ninety (90) Calendar Days** from and including the Starting Date, plus such additional days, if any, which are expressly granted as extensions of time by Contract Change Orders signed and issued by the County. Such total number of days shall be referred to herein as the "Time for Completion".

Failure of the Contractor to perform any covenant or condition contained in the Contract Documents within the time period specified shall constitute material breach of this Contract entitling the County to terminate the Contract unless the Contractor applies for, and receives, an extension of time in accordance with the procedures set forth in Section 1017.09 SS, "EXTENSION OF TIME."

### **8-1.10 LIQUIDATED DAMAGES**

In accordance with Government Code Section 53069.85, the Contractor shall pay to the County of Inyo, liquidated damages in the amounts of:

**\$250.00** per day for each and every calendar day delay in finishing the work in excess of the Time for Completion specified.

The County shall be entitled to deduct the amounts of liquidated damages from any payment otherwise due to the Contractor.

## **PUBLIC CONTRACT CODE SECTION 9204**

(a) The Legislature finds and declares that it is in the best interests of the state and its citizens to ensure that all construction business performed on a public works project in the state that is complete and not in dispute is paid in full and in a timely manner.

(b) Notwithstanding any other law, including, but not limited to, Article 7.1 (commencing with Section 10240) of Chapter 1 of Part 2, Chapter 10 (commencing with Section 19100) of Part 2, and Article 1.5 (commencing with Section 20104) of Chapter 1 of Part 3, this section shall apply to any claim by a contractor in connection with a public works project.

(c) For purposes of this section:

(1) "Claim" means a separate demand by a contractor sent by registered mail or certified mail with return receipt requested, for one or more of the following:

(A) A time extension, including, without limitation, for relief from damages or penalties for delay assessed by a public entity under a contract for a public works project.

(B) Payment by the public entity of money or damages arising from work done by, or on behalf of, the contractor pursuant to the contract for a public works project and payment for which is not otherwise expressly provided or to which the claimant is not otherwise entitled.

(C) Payment of an amount that is disputed by the public entity.

(2) "Contractor" means any type of contractor within the meaning of Chapter 9 (commencing with Section 7000) of Division 3 of the Business and Professions Code who has entered into a direct contract with a public entity for a public works project.

(3) (A) "Public entity" means, without limitation, except as provided in subparagraph (B), a state agency, department, office, division, bureau, board, or commission, the California State University, the University of California, a city, including a charter city, county, including a charter county, city and county, including a charter city and county, district, special district, public authority, political subdivision, public corporation, or nonprofit transit corporation wholly owned by a public agency and formed to carry out the purposes of the public agency.

(B) "Public entity" shall not include the following:

(i) The Department of Water Resources as to any project under the jurisdiction of that department.

(ii) The Department of Transportation as to any project under the jurisdiction of that department.

(iii) The Department of Parks and Recreation as to any project under the jurisdiction of that department.

(iv) The Department of Corrections and Rehabilitation with respect to any project under its jurisdiction pursuant to Chapter 11 (commencing with Section 7000) of Title 7 of Part 3 of the Penal Code.

(v) The Military Department as to any project under the jurisdiction of that department.

(vi) The Department of General Services as to all other projects.

(vii) The High-Speed Rail Authority.

(4) "Public works project" means the erection, construction, alteration, repair, or improvement of any public structure, building, road, or other public improvement of any kind.

(5) "Subcontractor" means any type of contractor within the meaning of Chapter 9 (commencing with Section 7000) of Division 3 of the Business and Professions Code who either is in direct contract with a contractor or is a lower tier subcontractor.

(d) (1) (A) Upon receipt of a claim pursuant to this section, the public entity to which the claim applies shall conduct a reasonable review of the claim and, within a period not to exceed 45 days, shall provide the claimant a written statement identifying what portion of the claim is disputed and what portion is undisputed. Upon receipt of a claim, a public entity and a contractor may, by mutual agreement, extend the time period provided in this subdivision.

(B) The claimant shall furnish reasonable documentation to support the claim.

(C) If the public entity needs approval from its governing body to provide the claimant a written statement identifying the disputed portion and the undisputed portion of the claim, and the governing body does not meet within the 45 days or within the mutually agreed to extension of time following receipt of a claim sent by registered mail or certified mail, return receipt requested, the public entity shall have up to three days following the next duly publicly noticed meeting of the governing body after the 45-day period, or extension, expires to provide the claimant a written statement identifying the disputed portion and the undisputed portion.

(D) Any payment due on an undisputed portion of the claim shall be processed and made within 60 days after the public entity issues its written statement. If the public entity fails to issue a written statement, paragraph (3) shall apply.

(2) (A) If the claimant disputes the public entity's written response, or if the public entity fails to respond to a claim issued pursuant to this section within the time prescribed, the claimant may demand in writing an informal conference to meet and confer for settlement of the issues in dispute. Upon receipt of a demand in writing sent by registered mail or certified mail, return receipt requested, the public entity shall schedule a meet and confer conference within 30 days for settlement of the dispute.

(B) Within 10 business days following the conclusion of the meet and confer conference, if the claim or any portion of the claim remains in dispute, the public entity shall provide the claimant a written statement identifying the portion of the claim that remains in dispute and the portion that is undisputed. Any payment due on an undisputed portion of the claim shall be processed and made within 60 days after the public entity issues its written statement. Any disputed portion of the claim, as identified by the contractor in writing, shall be submitted to nonbinding mediation, with the public entity and the claimant sharing the associated costs equally. The public entity and claimant shall mutually agree to a mediator within 10 business days after the disputed portion of the claim has been identified in writing. If the parties cannot agree upon a mediator, each party shall select a mediator and those mediators shall select a qualified neutral third party to mediate with regard to the disputed portion of the claim. Each party shall bear the fees and costs charged by its respective mediator in connection with the selection of the neutral mediator. If mediation is unsuccessful, the parts of the claim remaining in dispute shall be subject to applicable procedures outside this section.

(C) For purposes of this section, mediation includes any nonbinding process, including, but not limited to, neutral evaluation or a dispute review board, in which an independent third party or board assists the parties in dispute resolution through negotiation or by issuance of an evaluation. Any mediation utilized shall conform to the timeframes in this section.

(D) Unless otherwise agreed to by the public entity and the contractor in writing, the mediation conducted pursuant to this section shall excuse any further obligation under Section 20104.4 to mediate after litigation has been commenced.

(E) This section does not preclude a public entity from requiring arbitration of disputes under private arbitration or the Public Works Contract Arbitration Program, if mediation under this section does not resolve the parties' dispute.

(3) Failure by the public entity to respond to a claim from a contractor within the time periods described in this subdivision or to otherwise meet the time requirements of this section shall result in the claim being deemed rejected in its entirety. A claim that is denied by reason of the public entity's failure to have responded to a claim, or its failure to otherwise meet the time requirements of this section, shall not constitute an adverse finding with regard to the merits of the claim or the responsibility or qualifications of the claimant.

(4) Amounts not paid in a timely manner as required by this section shall bear interest at 7 percent per annum.

(5) If a subcontractor or a lower tier subcontractor lacks legal standing to assert a claim against a public entity because privity of contract does not exist, the contractor may present to the public entity a claim on behalf of a

subcontractor or lower tier subcontractor. A subcontractor may request in writing, either on his or her own behalf or on behalf of a lower tier subcontractor, that the contractor present a claim for work which was performed by the subcontractor or by a lower tier subcontractor on behalf of the subcontractor. The subcontractor requesting that the claim be presented to the public entity shall furnish reasonable documentation to support the claim. Within 45 days of receipt of this written request, the contractor shall notify the subcontractor in writing as to whether the contractor presented the claim to the public entity and, if the original contractor did not present the claim, provide the subcontractor with a statement of the reasons for not having done so.

(e) The text of this section or a summary of it shall be set forth in the plans or specifications for any public works project that may give rise to a claim under this section.

(f) A waiver of the rights granted by this section is void and contrary to public policy, provided, however, that (1) upon receipt of a claim, the parties may mutually agree to waive, in writing, mediation and proceed directly to the commencement of a civil action or binding arbitration, as applicable; and (2) a public entity may prescribe reasonable change order, claim, and dispute resolution procedures and requirements in addition to the provisions of this section, so long as the contractual provisions do not conflict with or otherwise impair the timeframes and procedures set forth in this section.

(g) This section applies to contracts entered into on or after January 1, 2017.

(h) Nothing in this section shall impose liability upon a public entity that makes loans or grants available through a competitive application process, for the failure of an awardee to meet its contractual obligations.

(i) This section shall remain in effect only until January 1, 2020, and as of that date is repealed, unless a later enacted statute, that is enacted before January 1, 2020, deletes or extends that date.

# **ELECTION EMERGENCY STANDBY GENERATORS INSTALLATION PROJECT**

## **PROJECT SCOPE**

[PAGE INTENTIONALLY LEFT BLANK]

# ELECTIONS EMERGENCY STANDBY GENERATORS PROJECT

## General Scope-of-Work:

The Elections Emergency Standby Generators Project is divided between five locations within Inyo County, California. The project includes sites in Bishop, Big Pine, Independence, and Lone Pine. The project includes the installation of five generators and five automatic transfer switches, all of which are furnished by Inyo County Public Works (product data sheets attached). The Contractor is responsible for reviewing the installation instructions and performing any and all work (including furnishing all labor (prevailing wages govern), materials, and equipment) necessary to provide a complete installation per the locally adopted building, electrical, and other applicable codes, as well as good industry practices and standards, including but not limited to:

1. Electrical design, single line drawings, and electrical calculations
2. Obtain all permits and pay all fees
3. Demolition, concrete saw cutting and breaking, and scanning for concealed pipes and conduits
4. Trenching, excavation, backfill, compaction
5. Concrete formwork, rebar, concrete materials, concrete placement and finishing, tenting, temporary heat, and concrete blankets for subgrade and concrete frost protection
6. Installation and connection of any above and below ground propane lines and tracer wires, and necessary appropriately sized pressure regulators
7. Grounding or bonding wires, clamps, and ground rods
8. Above and below ground PVC, EMT, Rigid, and Flexible conduit
9. Panels, conductors, and circuit breakers
10. Daily and final cleanup, offhauling of trash, crating materials, and debris, payment of dump fees, and final grading
11. Startup, testing, commissioning of the generators and transfer switches
12. Training of the applicable County personnel on the operation of said equipment.
13. Contractor is to submit a layout defining the proposed sizing and layout of conduits, cut sheets for materials to be used, etc. to County Engineer for review and approval by the Building Official prior to starting work.
14. No change orders allowed. Contractor to provide for all contingencies.



## **Venue #1 – Tri-County Fairgrounds, 475 Sierra Street, Bishop, CA**

This scope of work includes all work necessary, whether reflected in this scope of work or not, to complete the installation of a Generac QT100 100 kW, Single Phase trailer-mounted generator and Generac 400 Amp automatic transfer switch (ATS), both of which will be provided by Inyo County Public Works.

The transfer switch will be permanently installed on doubled Unistrut uprights set in concrete footings or other suitable method of attachment adjacent to the main switchgear, the connection of the trailer-mounted generator using flexible propane hoses utilizing quick disconnect propane fittings and an appropriately sized propane pressure regulator, and electrical twist-lock type electrical connections and cords for connecting generator power, battery charger circuit, block heater circuit, and control wiring circuits, the interception of the subfeed from the applicable breaker (Home Economics) in the Main Switchgear. The propane tank and pad will be furnished and installed by the Tri-County Fair personnel. Contractor is responsible for the design of all work, and must submit a plan, single line drawing, and product data sheets with respect to conduit size and material, conduit routing, conductor and breaker sizing, trailer grounding or bonding, etc. for approval by the Building Official and the County Engineer prior to commencing work.









# LEGEND

- 1. Propane Tanks (N) - by Fairgrounds
- 2. Buried Propane Line (N)
- 3. Concrete Pad (E)
- 4. Generac QT100 Generator (N) - County Furnished, Contractor Installed
- 5. High to Medium Propane Regulator (N)
- 6. Automatic Transfer Switch - County Furnished, Contractor Install
- 7. Generator Power Circuit (N)
- 8. Control Wiring Circuit (N)
- 9. Block Heater & Battery Charger Circuit (N)
- 10. Main Switchgear (E) - To Remain
- 11. Home Economics Building - Subfeed Breaker (E)
- 12. SCE Transformer (E)
- 13. Medium to Low Propane Regulator (N)
- 14. Flat Bed Trailer (N) - By Inyo County
- 15. Electric Vault (E)
- 16. Fair Office Step Down Transformer (E)

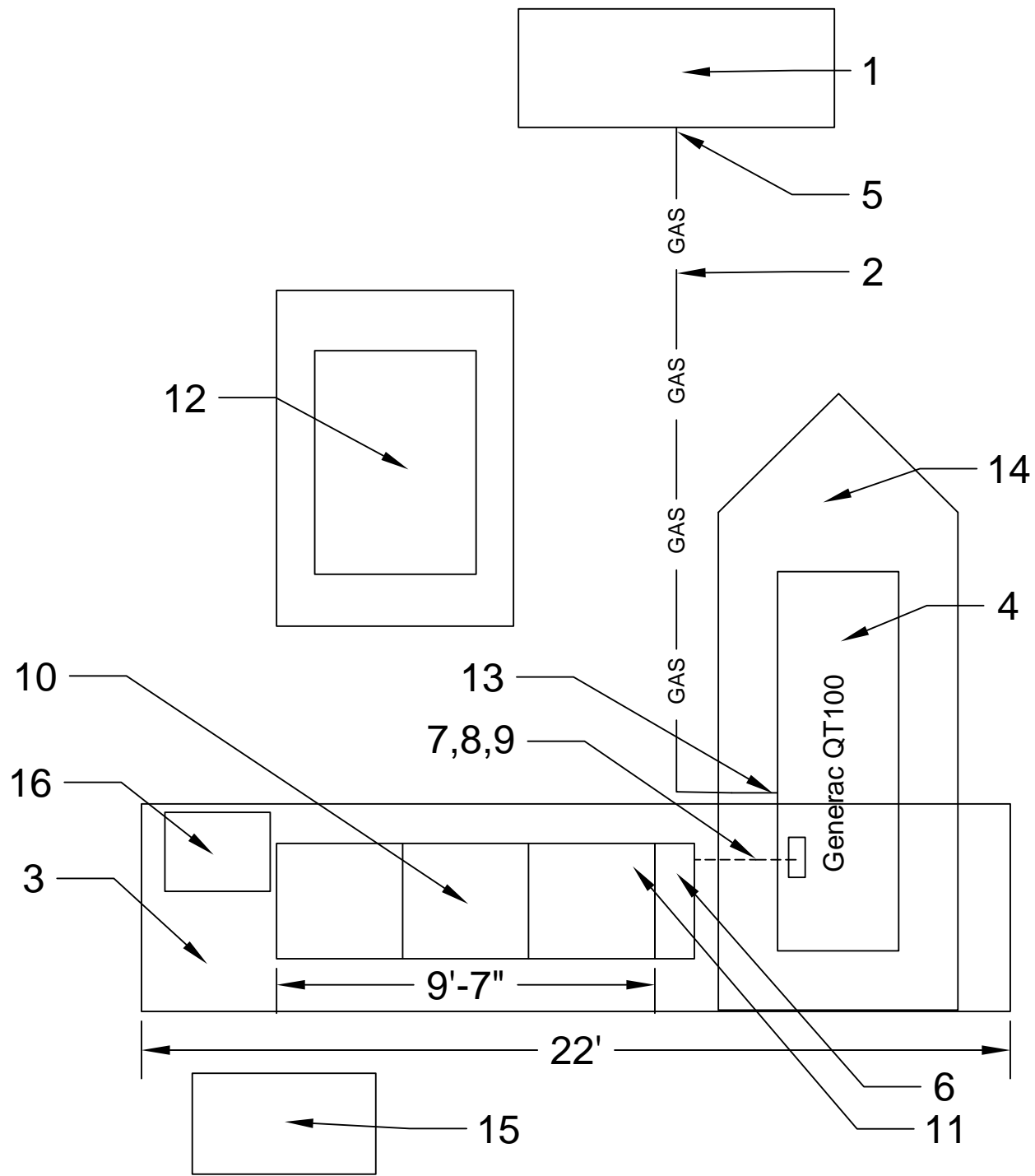

**Tri-County Fairgrounds  
General Arrangement Layout**

Inyo County Public Works  
Design: GLW 10/20/2020  
Scale:  $\frac{1}{4}$ " = 1' - 0", @ 11" x 17"

## Standby Generators

### Standby Generators Liquid-Cooled Gaseous Engine

#### Tri-County Fairgrounds

#### INCLUDES:

- Two Line LCD Tri-Lingual Digital Nexus™ Controller
- Isochronous Electronic Governor
- Sound Attenuated Enclosure
- Closed Coolant Recovery System
- Smart Battery Charger
- UV/Ozone Resistant Hoses
- ±1% Voltage Regulation
- Natural Gas or LP Operation
- 2 Year Limited Warranty
- UL 2200 Listed

#### Standby Power Rating

- Model QT070 (Aluminum - Bisque) - 70 kW 60 Hz
- Model QT080 (Aluminum - Bisque) - 80 kW 60 Hz
- Model QT100 (Aluminum - Bisque) - 100 kW 60 Hz
- Model QT130 (Aluminum - Bisque) - 130 kW 60 Hz
- Model QT150 (Aluminum - Bisque) - 150 kW 60 Hz



QUIET-TEST™

Meets EPA Emission Regulations

70, 100, 130 & 150 kW meet CA/MA emissions requirement with optional catalyst  
80 kW not for sale in CA/MA

## FEATURES

- **INNOVATIVE DESIGN & PROTOTYPE TESTING** are key components of GENERAC'S success in "IMPROVING POWER BY DESIGN." But it doesn't stop there. Total commitment to component testing, reliability testing, environmental testing, destruction and life testing, plus testing to applicable CSA, NEMA, EGSA, and other standards, allows you to choose GENERAC POWER SYSTEMS with the confidence that these systems will provide superior performance.
- **TEST CRITERIA:**
  - ✓ PROTOTYPE TESTED
  - ✓ SYSTEM TORSIONAL TESTED
  - ✓ NEMA MG1-22 EVALUATION
  - ✓ MOTOR STARTING ABILITY
- **SOLID-STATE, FREQUENCY COMPENSATED VOLTAGE REGULATION.** This state-of-the-art power maximizing regulation system is standard on all Generac models. It provides optimized FAST RESPONSE to changing load conditions and MAXIMUM MOTOR STARTING CAPABILITY by electronically torque-matching the surge loads to the engine. Digital voltage regulation at ±1%.
- **SINGLE SOURCE SERVICE RESPONSE** from Generac's extensive dealer network provides parts and service know-how for the entire unit, from the engine to the smallest electronic component.
- **GENERAC TRANSFER SWITCHES.** Long life and reliability are synonymous with GENERAC POWER SYSTEMS. One reason for this confidence is that the GENERAC product line includes its own transfer systems and controls for total system compatibility.

## 70 • 80 • 100 • 130 • 150 kW

## application &amp; engineering data

## GENERATOR SPECIFICATIONS

Type	Synchronous
Rotor Insulation Class	H
Stator Insulation Class	H
Telephone Interference Factor (TIF)	<50
Alternator Output Leads 1-Phase	4 wire
Alternator Output Leads 3-Phase	6 wire (70, 80 & 150 kW) or 12 wire (100 & 130 kW)
Bearings	Sealed Ball
Coupling	Flexible Disc (70, 80 & 150 kW) or Gear Drive (100 & 130 kW)
Excitation System	Brushless

## VOLTAGE REGULATION

Type	Electronic
Sensing	Single Phase
Regulation	± 1%

## GOVERNOR SPECIFICATIONS

Type	Electronic
Frequency Regulation	Isochronous
Steady State Regulation	± 0.25%

## ELECTRICAL SYSTEM

Battery Charge Alternator	12 Volt 30 Amp
Static Battery Charger	2 Amp
Recommended Battery (battery not included)	Group 24F, 525 CCA (70, 80 & 150 kW) or Group 27F, 700 CCA (100 & 130 kW)
System Voltage	12 Volts

## GENERATOR FEATURES

Revolving field heavy duty generator  
Directly connected to the engine  
Operating temperature rise 120 °C above a 40 °C ambient  
Class H insulation is NEMA rated  
All models fully prototyped tested

## ENCLOSURE FEATURES

Aluminum weather protective enclosure	Ensures protection against mother nature. Electrostatically applied textured epoxy paint for added durability.
Enclosed critical grade muffler	Quiet, critical grade muffler is mounted inside the unit to prevent injuries.
Small, compact, attractive	Makes for an easy, eye appealing installation.
SAE	Sound attenuated enclosure ensures quiet operation.

## ENGINE SPECIFICATIONS: 80 kW

Make	Generac
Model	V-Type
Cylinders	8
Displacement (Liters)	5.4
Bore (in/mm)	3.55/90.2
Stroke (in/mm)	4.17/105.9
Compression Ratio	9:1
Intake Air System	Naturally Aspirated
Lifter Type	Hydraulic

## ENGINE SPECIFICATIONS: 70, 100, 130 &amp; 150 kW

Make	Generac
Model	V-Type
Cylinders	10
Displacement (Liters)	6.8
Bore (in/mm)	3.55/90.2
Stroke (in/mm)	4.17/105.9
Compression Ratio	9:1
Intake Air System	Naturally Aspirated
Lifter Type	Hydraulic

## ENGINE LUBRICATION SYSTEM

Oil Pump Type	Gear
Oil Filter Type	Full flow spin-on cartridge
Crankcase Capacity (qt/l)	5/4.7 (70, 100, 130 & 150 kW) or 6/5.7 (80 kW)

## ENGINE COOLING SYSTEM

Type	Closed
Water Pump	Belt driven
Fan Speed (rpm)	2300 - 70 kW 2174 - 80 kW 1670 - 100 kW 1950 - 130 kW 2200 - 150 kW
Fan Diameter (in/mm)	22/558.8 (70 kW) or 26/660.4 (80, 100, 130 & 150 kW)
Fan Mode	Pusher (70 kW) or Puller (80, 100, 130 & 150 kW)

## FUEL SYSTEM

Fuel Type	Natural gas, propane vapor
Carburetor	Down Draft
Secondary Fuel Regulator	Standard
Fuel Shut Off Solenoid	Standard
Operating Fuel Pressure	11-14" water column/21-26 mm HG



## 70 • 80 • 100 • 130 • 150 kW

## operating data

### GENERATOR OUTPUT VOLTAGE/kW - 60 Hz

		kW LPG	Amp LPG	kW Nat. Gas	Amp Nat. Gas	CB Size (Both)
QT070	120/240 V, 1Ø, 1.0 pf	67	292	64	267	300
	120/208 V, 3Ø, 0.8 pf	70	243	67	232	300
	120/240 V, 3Ø, 0.8 pf	70	211	67	201	250
	277/480 V, 3Ø, 0.8 pf	70	105	67	101	125
QT080	120/240 V, 1Ø, 1.0 pf	77	333	77	333	400
	120/208 V, 3Ø, 0.8 pf	80	278	80	278	300
	120/240 V, 3Ø, 0.8 pf	80	241	80	240	300
	277/480 V, 3Ø, 0.8 pf	80	120	80	120	150
QT100	120/240 V, 1Ø, 1.0 pf	100	417	89	371	450
	120/208 V, 3Ø, 0.8 pf	100	347	94	326	400
	120/240 V, 3Ø, 0.8 pf	100	301	94	283	350
	277/480 V, 3Ø, 0.8 pf	100	150	94	141	175
QT130	120/240 V, 1Ø, 1.0 pf	130	542	117	488	600
	120/208 V, 3Ø, 0.8 pf	130	451	122	423	500
	120/240 V, 3Ø, 0.8 pf	130	391	122	367	450
	277/480 V, 3Ø, 0.8 pf	130	195	122	183	225
QT150	120/240 V, 1Ø, 1.0 pf	144	625	136	567	700
	120/208 V, 3Ø, 0.8 pf	150	520	142	493	600
	120/240 V, 3Ø, 0.8 pf	150	451	142	427	500
	277/480 V, 3Ø, 0.8 pf	150	225	142	214	250

3 of 9

### SURGE CAPACITY IN AMPS

		Voltage Dip @ < .4 pf	
		15%	30%
QT070	120/240 V, 1Ø	129	356
	120/208 V, 3Ø	194	471
	120/240 V, 3Ø	168	408
	277/480 V, 3Ø	83	201
QT080	120/240 V, 1Ø	174	435
	120/208 V, 3Ø	186	466
	120/240 V, 3Ø	161	404
	277/480 V, 3Ø	70	175
QT100	120/240 V, 1Ø	150	413
	120/208 V, 3Ø	186	452
	120/240 V, 3Ø	161	392
	277/480 V, 3Ø	107	261
QT130	120/240 V, 1Ø	236	648
	120/208 V, 3Ø	364	885
	120/240 V, 3Ø	315	767
	277/480 V, 3Ø	161	390
QT150	120/240 V, 1Ø	486	1214
	120/208 V, 3Ø	534	1334
	120/240 V, 3Ø	463	1156
	277/480 V, 3Ø	250	624

### ENGINE FUEL CONSUMPTION

		Natural Gas		Propane		
		(ft³/hr)	(m³/hr)	(gal/hr)	(l/hr)	(ft³/hr)
QT070	Exercise cycle	110	3.1	1.2	4.6	44
	25% of rated load	260	7.4	2.85	10.8	104
	50% of rated load	500	14.2	5.46	20.8	200
	75% of rated load	696	19.8	7.62	29.1	280
	100% of rated load	1020	29	11.17	42.6	411
QT080	Exercise cycle	95	2.7	1.4	5.51	53
	25% of rated load	549.5	15.6	3.46	13.11	126
	50% of rated load	784.4	22.2	6.62	25.1	241
	75% of rated load	1024.8	29.0	9.24	34.96	336
	100% of rated load	1252.2	35.5	12.78	48.38	465
QT100	Exercise cycle	130	3.7	1.4	5.4	52
	25% of rated load	371	10.5	4.1	15.5	149
	50% of rated load	713	20.3	7.9	29.8	287
	75% of rated load	991	28.2	11	41.5	400
	100% of rated load	1260	35.8	13.9	52.6	507
QT130	Exercise cycle	135	3.8	1.4	5.7	55
	25% of rated load	482	13.7	5.3	20	193
	50% of rated load	927	26.3	10.3	38.7	373
	75% of rated load	1292	36.7	14.3	54	520
	100% of rated load	1786	50.8	19.8	74.6	719
QT150	Exercise cycle	155	4.4	1.7	6.5	63
	25% of rated load	556	15.8	6.09	23.2	224
	50% of rated load	1070	30.4	11.72	44.7	431
	75% of rated load	1491	42.4	16.33	62.3	600
	100% of rated load	2061	58.6	22.57	86.1	830

Note: Fuel pipe must be sized for full load.

For BTU content, multiply ft³/hr x 2500 (LP) or ft³/hr x 1000 (NG).

For Megajoule content, multiply m³/hr x 93.15 (LP) or m³/hr x 37.26 (NG).

Refer to "Emissions Data Sheets" for maximum fuel flow for EPA and SCAQMD permitting purposes.

STANDBY RATING: Standby ratings apply to installations served by a reliable utility source. The standby rating is applicable to varying loads for the duration of a power outage. There is no overload capability for this rating. Ratings are in accordance with ISO-3046-1. Design and specifications are subject to change without notice.



70 • 80 • 100 • 130 • 150 kW

operating data

## ENGINE COOLING

	70 kW	80 kW	100 kW	130 kW	150 kW
Air flow (inlet air including alternator and combustion air in ft <sup>3</sup> /min)	5200/147.2	5300/150.1	5500/155.7	6450/182.6	7800/220.9
System coolant capacity (gal/liters)	4.5/17	4/15.1	4.5/17	4.5/17	4.5/17
Heat rejection to coolant (BTU/hr)	287,000/302.8	316,000/333.4	342,000/360.8	496,000/523.3	568,000/599.3
Maximum operation air temperature on radiator (°C/°F)	60/150				
Maximum ambient temperature (°C/°F)	50/140				

## COMBUSTION REQUIREMENTS

Flow at rated power (cfm/cmm)	205/5.8	143/4	262/7.4	336/9.5	410/11.6
-------------------------------	---------	-------	---------	---------	----------

## SOUND EMISSIONS

Sound output in dB(A) at 23 ft (7 m) with generator in exercise mode*	64	65	68	69	66
Sound output in dB(A) at 23 ft (7 m) with generator operating at normal load*	72	74	72	75	79

\*Sound levels are taken from the front of the generator. Sound levels taken from other sides of the generator may be higher depending on installation parameters.

## EXHAUST

Exhaust flow at rated output (cfm/cmm)	557/15.8	720/20.4	888/25.1	1119/31.7	1535/43.5
Exhaust temperature at muffler outlet (°C/°F)	477/890	796/1465	516/960	521/970	593/1100

## ENGINE PARAMETERS

Rated Synchronous rpm	1800	3600	2300	2970	3600
-----------------------	------	------	------	------	------

## POWER ADJUSTMENT FOR AMBIENT CONDITIONS

Temperature Deration .....	3% for every 10 °C above 25 °C or 1.65% for every 10 °F above 77 °F
Altitude Deration (70,100,130 & 150) .....	1% for every 100 m above 183 m or 3% for every 1000 ft above 600 ft
Altitude Deration (80 kW) .....	1% for every 100 m above 915 m or 3% for every 1000 ft above 3000 ft

## CONTROLLER FEATURES

2-Line Plain Text LCD Display .....	Simple user interface for ease of operation.
Mode Switch: Auto .....	Automatic Start on Utility failure. 7 day exerciser
Off .....	Stops unit. Power is removed. Control and charger still operate.
Manual .....	Start with starter control, unit stays on. If utility fails, transfer to load takes place.
Programmable start delay between 10-30 seconds .....	Standard 10 sec
Engine Start Sequence .....	Cyclic cranking: 16 sec on, 7 rest (90 sec maximum duration)
Engine Warm-up .....	5 sec
Engine Cool-Down .....	1 min
Starter Lock-out .....	Starter cannot re-engage until 5 sec after engine has stopped.
Smart Battery Charger .....	Standard
Automatic Voltage Regulation with Over and Under Voltage Protection .....	Standard
Automatic Low Oil Pressure Shutdown .....	Standard
Overspeed Shutdown .....	Standard, 72 Hz
High Temperature Shutdown .....	Standard
Overcrank Protection .....	Standard
Safety Fused .....	Standard
Failure to Transfer Protection .....	Standard
Low Battery Protection .....	Standard
50 Event Run Log .....	Standard
Future Set Capable Exerciser .....	Standard
Incorrect Wiring Protection .....	Standard
Internal Fault Protection .....	Standard
Common External Fault Capability .....	Standard
Governor Failure Protection .....	Standard

Model #	Product	Description
G006463-4	Mobile Link™	Generac's Mobile Link allows you to check the status of your generator from anywhere that you have access to an Internet connection from a PC or with any smart device. You will even be notified when a change in the generator's status occurs via e-mail or text message. Note: Harness Adapter Kit required. Available in the U.S. only.
G006478-0	Harness Adapter Kit	The Harness Adapter Kit is required to make liquid-cooled units compatible with Mobile Link™.
G005632-1 - 70, 80 & 150 kW G005633-0 - 100 & 130 kW	Cold Weather Kit	If the temperature regularly falls below 32 °F (0 °C), install a cold weather kit to maintain optimal battery temperature. Kit consists of battery warmer with thermostat built into the wrap.
G005620-0 - 70, 100 & 130 kW G006204-0 - 80 kW G005667-0 - 150 kW	Extreme Cold Weather Kit	Recommended where the temperature regularly falls below 32 °F (0 °C) for extended periods of time. For liquid cooled units only.
G005651-0	Base Plug Kit	Add base plugs to the base of the generator to keep out debris.
G005703-0	Paint Kit	If the generator enclosure is scratched or damaged, it is important to touch-up the paint to protect from future corrosion. The paint kit includes the necessary paint to properly maintain or touch-up a generator enclosure.
G005660-0 - 70, 100, 130, and 150 kW G006915-0 - 80 kW	Scheduled Maintenance Kit	The Liquid-Cooled Scheduled Maintenance Kits offer all the hardware necessary to perform complete maintenance on Generac liquid-cooled generators.
G006664-0	Local Wireless Monitor	Completely wireless and battery powered, Generac's wireless remote monitor provides you with instant status information without ever leaving the house.
G006665-0	Wireless Remote Extension Harness	Recommended for use with the Wireless Remote on units up to 60 kW, required for use on units 70 kW or greater.
G006873-0	Smart Management Module (50 Amps)	Smart Management Modules are used in conjunction with the Automatic Transfer Switch to increase its power management capabilities. It provides additional power management flexibility not found in any other power management system.
G007005-0	Wi-Fi LP Fuel Level Monitor	The Wi-Fi enabled LP fuel level monitor provides constant monitoring of the connected LP fuel tank. Monitoring the LP tank's fuel level is an important step in making sure your generator is ready to run during an unexpected power failure. Status alerts are available through a free application to notify when your LP tank is in need of a refill.
G006510-0	E-Stop	E-stop allows for immediate fuel shutoff and generator shutdown in the event of an emergency.

TRI-COUNTY, BIG PINE, STATHAM HALL  
400A, 120/240V, SINGLE PHASE

## Automatic Transfer Switches

## Service and non-Service rated Automatic Smart Transfer Switches

100 - 400 Amps, Single Phase

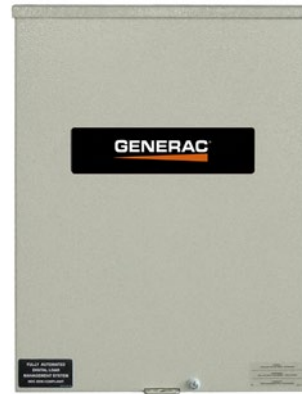
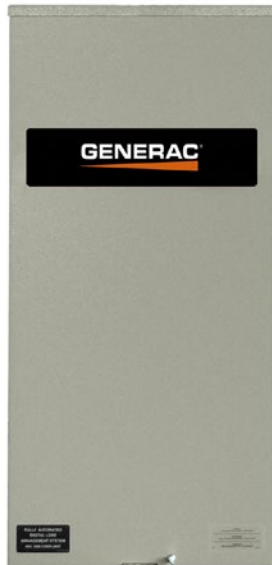

\*Built in the USA using domestic and foreign parts

\*CUL only applies to non-service rated switches

### Description

Generac Automatic Transfer Switches are designed for use with single phase generators that utilize an Evolution™ or Nexus™ Controller. The 100, 200, and 400 amp open transition switches are available in single phase in both service equipment rated and non-service equipment rated configurations. The 150 and 300 amp open transition switches are only available in a service rated equipment configuration.

### Standard Features

Service rated (RTSW) Generac Automatic Transfer Switches are housed in an aluminum NEMA/UL Type 3R enclosure\*, with electrostatically applied and baked powder paint. The Heavy Duty Generac Contactor is a UL recognized device, designed for years of service. The controller at the generator handles all the timing, sensing, exercising functions, and transfer commands. All switches are covered by a 5 year limited warranty.

\* Non-service rated (RTSC) switches are housed in a steel enclosure.

### DPM Technology

Through the use of digital power technology (DPM), these switches have the capability to manage up to 4 individual HVAC (24 VAC controlled) loads with no additional hardware. When used in tandem with Smart Management Modules, up to 8 more loads can be managed as well, providing the most installation efficient power management options available.

# 100-400 Amps, Single Phase

# Automatic Smart Transfer Switches

## Functions

All timing and sensing functions originate in the generator controller

Utility voltage drop-out.....	<60%
Timer to generator start.....	10 second factory set, adjustable between 2-1500 seconds by a qualified dealer*
Engine warm up delay.....	5 seconds
Standby voltage sensor.....	60% for 5 seconds
Utility voltage pickup.....	>80%
Re-transfer time delay.....	15 seconds
Engine cool-down timer.....	60 seconds
Exerciser.....	12 minutes every 7 days

The transfer switch can be operated manually without power applied.

\*When used in conjunction with units utilizing Evolution™ controls

## Specifications

Model	RTSC100A3	RTSW100A3	RTSW150A3	RTSC200A3	RTSW200A3	RTSW300A3	RTSC400A3	RTSW400A3
Amps	100	100	150	200	200	300	400	400
Voltage	120/240, 1Ø	120/240, 1Ø	120/240, 1Ø	120/240, 1Ø	120/240, 1Ø	120/240, 1Ø	120/240, 1Ø	120/240, 1Ø
Load Transition Type (Automatic)	Open Transition	Open Transition Service Rated	Open Transition Service Rated	Open Transition	Open Transition Service Rated	Open Transition Service Rated	Open Transition	Open Transition Service Rated
Enclosure Type	NEMA/UL 3R	NEMA/UL 3R	NEMA/UL 3R	NEMA/UL 3R	NEMA/UL 3R	NEMA/UL 3R	NEMA/UL 3R	NEMA/UL 3R
UL Rating	UL/CUL	UL	UL	UL/CUL	UL	UL	UL/CUL	UL
Withstand Rating (Amps)	10,000	10,000	22,000	10,000	22,000	22,000	22,000	22,000
Lug Range	1/0 - #14		250 MCM - #6			600 MCM - #4 or 1/0 - 250 MCM		

## Dimensions

Model		RTSC100A3	RTSW100A3	RTSW150A3	RTSC200A3	RTSW200A3	RTSW300A3	RTSC400A3	RTSW400A3
Height (in./mm)	H1	17.24/437.9	17.24/437.9	26.75/679.4	17.24/437.9	26.75/679.4	42.91/1089.9	31.25/793.8	42.91/1089.9
	H2	20/508	20/508	30/762	20/508	30/762	48/1219.2	36/914.4	48/1219.2
Width (in./mm)	W1	12.5/317.5	12.5/317.5	10.5/266.7	12.5/317.5	10.5/266.7	16.69/423.9	19.18/487.2	16.69/423.9
	W2	14.6/370.8	14.6/370.8	13.5/342.9	14.6/370.8	13.5/342.9	21.82/554.2	24/609.6	21.82/554.2
Depth (in./mm)		7.09/180.1	7.09/180.1	6.3/160.1	7.09/180.1	6.3/160.1	10.06/255.5	10.06/255.5	10.06/255.5
Weight (lbs./kilos)		20/9.07	22.5/10.21	39/17.69	20/9.07	39/17.69	140/63.5	133/60.33	140/63.5

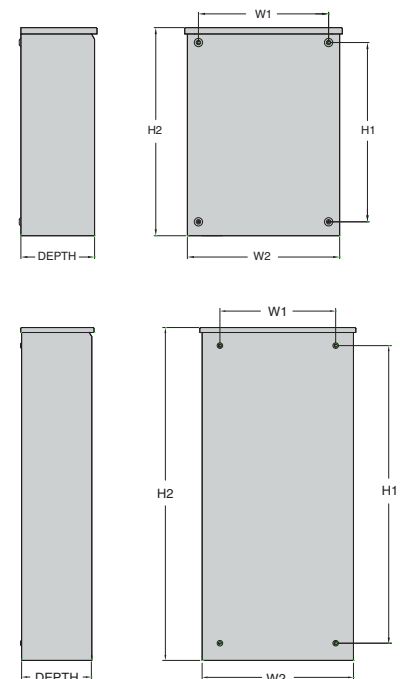

## **Venue #2 – Big Pine Town Hall, 180 Dewey Street, Big Pine, CA**

This scope of work includes all work (labor, materials, and equipment) necessary, whether reflected in this scope of work or not, to complete the installation of a Generac RG048 48 kW, Single Phase generator and Generac 400 Amp automatic transfer switch (ATS), both of which will be provided by Inyo County Public Works.

This scope of work includes but is not limited to an 8” concrete generator pad including excavation and subgrade compaction, formwork, rebar, concrete materials, concrete placement and finishing, concrete blankets for subgrade and concrete frost protection. Adjustment of existing underground propane line, installation of a properly sized propane pressure regulator, installation of above-grade propane lines, setting of generator on concrete pad including any crane costs, installation of surface mounted conduit for generator power, battery charger circuit, block heater circuit, and control wiring, interception and connection to the existing subfeed from main breaker to distribution panel, addition of an additional subpanel for generator battery charging and block heater circuits, and the installation of the automatic transfer switch. Contractor is responsible for the design of all work, and must submit a plan, single line drawing, and product data sheets with respect to conduit size and material, conduit routing, conductor and breaker sizing, grounding or bonding, etc. for approval by the Building Official and the County Engineer prior to commencing work.



















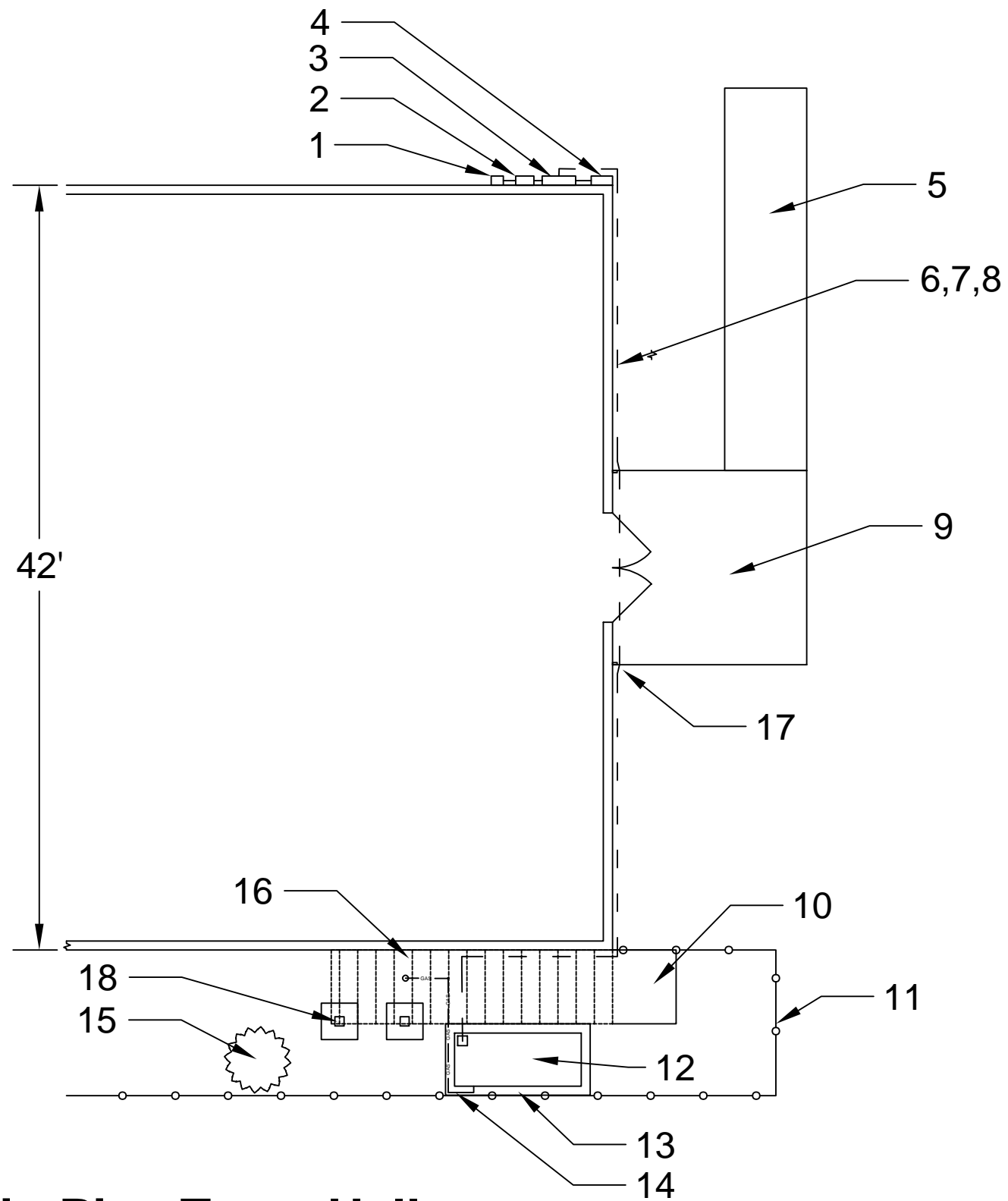

## LEGEND

1. Electrical J Box (E)
2. Subpanel (N) - Subfeed breakers, block heater and battery charger breakers
3. Automatic Transfer Switch (N) - County Furnished, Contractor Install
4. Meter Main Service (E)
5. ADA Ramp (E)
6. Generator Power (N) - bolted to foundation
7. Control Wiring Circuit (N) - bolted to foundation
8. Block Heater & Battery Charger Circuit (N) - bolted to foundation
9. Entry Platform (E)
10. Concrete Stair Landing (E)
11. Chain Link Fence (E)
12. Generac RG48 Generator (N) - County Furnished, Contractor Installed
13. Concrete Pad (N)
14. Above-Ground Propane Line w/ Pressure Regulator (N)
15. Tree (E)
16. Steel Stairway (E)
17. Bend conduit out at each side of Entry Platform to clear legs
18. Stair upper landing footings (E)

### Big Pine Town Hall General Arrangement Layout

Inyo County Public Works  
 Design: GLW 10/20/2020  
 Scale:  $\frac{1}{8}" = 1' - 0"$ , @ 11" x 17"

## Protector® Series

### PROTECTOR® SERIES Standby Generators Liquid-Cooled Gaseous Engine

Big Pine Town Hall, RG48KW

1 of 7

#### INCLUDES:

- Two-Line LCD Multilingual Digital Evolution™ Controller (English/Spanish/French/Portuguese) With External Viewing Window for Easy Indication of Generator Status and Breaker Position.
- SwRI® listed (NFPA37, clause 4.1.4.1.2) Generator can be installed a minimum 18" distance from combustible walls\*
- Isochronous Electronic Governor
- Sound Attenuated Enclosure
- Closed Coolant Recovery System
- Smart Battery Charger
- UV/Ozone Resistant Hoses
- ±1% Voltage Regulation
- Field Convertible Fuel Type With No Mechanical Adjustment Required.
- 5 Year Limited Warranty
- UL 2200 Listed

\*Only if located away from doors, windows, and fresh air intakes, and unless otherwise directed by local codes. Please review install guide for more details.

Standby Power Rating

Model RG048 (Aluminum - Bisque) - 48 kW 60 Hz



QUIET-TEST™

\*Assembled in the USA using domestic and foreign parts

Meets EPA Emission Regulations

## FEATURES

- **INNOVATIVE DESIGN & PROTOTYPE TESTING** are key components of GENERAC'S success in "IMPROVING POWER BY DESIGN." But it doesn't stop there. Total commitment to component testing, reliability testing, environmental testing, destruction and life testing, plus testing to applicable CSA, NEMA, EGSA, and other standards, allows you to choose GENERAC POWER SYSTEMS with the confidence that these systems will provide superior performance.
- **TEST CRITERIA:**
  - ✓ **PROTOTYPE TESTED**
  - ✓ **SYSTEM TORSIONAL TESTED**
  - ✓ **NEMA MG1-22 EVALUATION**
  - ✓ **MOTOR STARTING ABILITY**
- **SOLID-STATE, FREQUENCY COMPENSATED VOLTAGE REGULATION.** This state-of-the-art power maximizing regulation system is standard on all Generac models. It provides optimized FAST RESPONSE to changing load conditions and MAXIMUM MOTOR STARTING CAPABILITY by electronically torque-matching the surge loads to the engine. Digital voltage regulation at ±1%.
- **SINGLE SOURCE SERVICE RESPONSE** from Generac's extensive dealer network provides parts and service know-how for the entire unit, from the engine to the smallest electronic component.
- **GENERAC TRANSFER SWITCHES.** Long life and reliability are synonymous with GENERAC POWER SYSTEMS. One reason for this confidence is the GENERAC product line is offered with its own transfer systems and controls for total system compatibility.

### 48 kW

#### GENERATOR SPECIFICATIONS

Type	Synchronous
Rotor Insulation Class	F (48 kW)
Stator Insulation Class	H
Telephone Interference Factor (TIF)	<50
Alternator Output Leads 1-Phase	4 wire
Alternator Output Leads 3-Phase	6 wire
Bearings	Sealed Ball
Coupling	Flexible Disc
Excitation System	Direct

#### VOLTAGE REGULATION

Type	Electronic
Sensing	Single Phase
Regulation	± 1%

#### GOVERNOR SPECIFICATIONS

Type	Electronic
Frequency Regulation	Isochronous
Steady State Regulation	± 0.25%

#### ELECTRICAL SYSTEM

Battery Charge Alternator	12 Volt 30 Amp
Static Battery Charger	2.5 Amp
Recommended Battery (battery not included)	Group 27F (48kW), 725CCA
System Voltage	12 Volts

#### GENERATOR FEATURES

<p>Revolving field heavy duty generator          Directly connected to the engine          Operating temperature rise 120 °C above a 40 °C ambient          Class H insulation is NEMA rated          Class F insulation is NEMA rated          All models fully prototyped tested</p>
------------------------------------------------------------------------------------------------------------------------------------------------------------------------------------------------------------------------------------------------------------------------------------------------------------

#### ENCLOSURE FEATURES

Aluminum weather protective enclosure	Ensures protection against mother nature. Electrostatically applied textured epoxy paint for added durability.
Enclosed critical grade muffler	Quiet, critical grade muffler is mounted inside the unit to prevent injuries.
Small, compact, attractive	Makes for an easy, eye appealing installation.
SAE	Sound attenuated enclosure ensures quiet operation.

#### ENGINE SPECIFICATIONS: 48 kW

Make	Generac
Model	Inline 4 cylinder
Cylinders	4
Displacement (Liters)	4.5
Bore (in/mm)	4.5/114.3
Stroke (in/mm)	4.25/107.95
Compression Ratio	9.9:1
Intake Air System	Naturally Aspirated
Lifter Type	Hydraulic

#### ENGINE LUBRICATION SYSTEM

Oil Pump Type	Gear
Oil Filter Type	Full Flow Spin-On Cartridge
Crankcase Capacity (qt/l)	11.6/11 (48 kW)

#### ENGINE COOLING SYSTEM

Type	Ethylene Glycol 50/50 Mix
Water Pump	Belt-Driven
Fan Speed (rpm)	2,100
Fan Diameter (in/mm)	20
Fan Mode	Pusher

#### FUEL SYSTEM

Fuel Type	Natural Gas, Propane Vapor
Fuel Shut Off Solenoid	Standard
Operating Fuel Pressure	3.5-14 Water Column/9-26 mm HG
LP Fuel Pressure	7 - 14" Water Column
NG Fuel Pressure	3.5 - 14" Water Column

**48 kW**

**GENERATOR OUTPUT VOLTAGE/kW - 60 Hz**

		<b>kW LPG</b>	<b>Amp LPG</b>	<b>kW Nat. Gas</b>	<b>Amp Nat. Gas</b>	<b>CB Size (Both)</b>
RG048	120/240 V, 1Ø, 1.0 pf	48	200	48	200	200
	120/208 V, 3Ø, 0.8 pf	48	167	48	167	175
	120/240 V, 3Ø, 0.8 pf	48	144	48	144	150
	277/480 V, 3Ø, 0.8 pf	48	72	48	72	80

**SURGE CAPACITY IN AMPS**

		<b>Voltage Dip @ &lt; .4 pf</b>	
		15%	30%
		RG048	120/240 V, 1Ø
	120/208 V, 3Ø	118	242
	120/240 V, 3Ø	97	189
	277/480 V, 3Ø	63.6	122.8

**ENGINE FUEL CONSUMPTION**

		<b>Natural Gas</b>		<b>Propane</b>	
		(ft <sup>3</sup> /hr)	(m <sup>3</sup> /hr)	(gal/hr)	(l/hr)
		RG048	Exercise cycle	—	—
	25% of rated load	201	5.7	2.88	104.7
	50% of rated load	336	9.5	4.16	151.3
	75% of rated load	447	12.7	5.28	192
	100% of rated load	604	17.1	6.61	240.4

Note: **Fuel pipe must be sized for full load.**

For Btu content, multiply ft<sup>3</sup>/hr x 2520 (LP) or ft<sup>3</sup>/hr x 1000 (NG)

For megajoule content, multiply m<sup>3</sup>/hr x 93.15 (LP) or m<sup>3</sup>/hr x 37.26 (NG)

Refer to "Emissions Data Sheets" for maximum fuel flow for EPA and SCAQMD permitting purposes.

STANDBY RATING: Standby ratings apply to installations served by a reliable utility source. The standby rating is applicable to varying loads for the duration of a power outage. There is no overload capability for this rating. Ratings are in accordance with ISO-3046-1. Design and specifications are subject to change without notice.

### 48 kW

#### ENGINE COOLING

	48 kW
Air Flow (inlet air including alternator and combustion air in cfm/cmm)	2,829/80.1
System Coolant Capacity (gal/liters)	2.9/11
Heat Rejection to Coolant (BTU per hr/MJ per hr)	201,060
Maximum Operation Air Temperature on Radiator (°C/°F)	60/150
Maximum Ambient Temperature (°C/°F)	50/140

#### COMBUSTION REQUIREMENTS

Flow at Rated Power (scfm/cmm)	92.7/2.6
--------------------------------	----------

#### SOUND EMISSIONS

Sound Output in dB(A) at 23 ft (7 m) With Generator in Exercise Mode*	68
Sound Output in dB(A) at 23 ft (7 m) With Generator Operating at Normal Load*	70

#### EXHAUST

Exhaust Flow at Rated Output (scfm/cmm)	104/10.6
Exhaust Temperature at Muffler Outlet (°C/°F)	507/945

#### ENGINE PARAMETERS

Rated Synchronous rpm	1,800
-----------------------	-------

#### POWER ADJUSTMENT FOR AMBIENT CONDITIONS

Temperature Deration ..... 3% for every 10 °C above 25 °C or 1.65% for every 10 °F above 77 °F  
 Altitude Deration.....1% for every 100 m above 183 m or 3% for every 1000 ft above 600 ft

#### CONTROLLER FEATURES

Two-Line Plain Text LCD Display..... Simple user interface for ease of operation.  
 Mode Switch: Auto ..... Automatic Start on Utility failure. 7 day exerciser  
                   Off ..... Stops unit. Power is removed. Control and charger still operate.  
                   Manual ..... Start with starter control, unit stays on. If utility fails, transfer to load takes place.  
 Programmable Start Delay Between 10-30 Seconds ..... 10 sec standard  
 Engine Start Sequence ..... Cyclic cranking: 16 sec on, 7 rest (90 sec maximum duration)  
 Engine Warm-up ..... 5 sec  
 Engine Cool-Down ..... 1 min  
 Starter Lock-Out ..... Starter cannot re-engage until 5 sec after engine has stopped.  
 Smart Battery Charger ..... Standard  
 Automatic Voltage Regulation With Over and Under Voltage Protection ..... Standard  
 Automatic Low Oil Pressure Shutdown ..... Standard  
 Overspeed Shutdown ..... Standard, 72 Hz  
 High Temperature Shutdown ..... Standard  
 Overcrank Protection ..... Standard  
 Safety Fused ..... Standard  
 Failure to Transfer Protection ..... Standard  
 Low Battery Protection ..... Standard  
 50 Event Run Log ..... Standard  
 Future Set Capable Exerciser ..... Standard  
 Incorrect Wiring Protection ..... Standard  
 Internal Fault Protection ..... Standard  
 Common External Fault Capability ..... Standard  
 Governor Failure Protection ..... Standard

Model #	Product	Description
G0071690	Mobile Link® 4G LTE Cellular Accessory	Generac's Mobile Link allows you to check the status of your generator from anywhere that you have access to an Internet connection from a PC or with any smart device. You will even be notified when a change in the generator's status occurs via e-mail or text message. Note: Harness Adapter Kit required. Available in the U.S. only.
G006478-0	Kit, Adapter Mobile Link L/C (Required for QT and RG Series)	The Harness Adapter Kit is required to make liquid-cooled units compatible with Mobile Link®
G007992-0	Cold Weather Kit	If the temperature regularly falls below 32 °F (0 °C), install a cold weather kit to maintain optimal battery temperature. Kit consists of battery warmer with thermostat built into the wrap.
G007990-0	Extreme Cold Weather Kit	Recommended where the temperature regularly falls below 32 °F (0 °C) for extended periods of time. For liquid cooled units only.
G005651-0	Base Plug Kit	Add base plugs to the base of the generator to keep out debris.
G005703-0 - Bisque	Paint Kit	If the generator enclosure is scratched or damaged, it is important to touch-up the paint to protect from future corrosion. The paint kit includes the necessary paint to properly maintain or touch-up a generator enclosure.
G007991-0	Scheduled Maintenance Kit	The Liquid-Cooled Scheduled Maintenance Kits offer all the hardware necessary to perform complete maintenance on Generac liquid-cooled generators.
G006664-0	Local Wireless Monitor	Completely wireless and battery powered, Generac's wireless remote monitor provides you with instant status information without ever leaving the house.
G006665-0	Wireless Remote Extension Harness	Recommended for use with the Wireless Remote on units up to 60 kW, required for use on units 70 kW or greater.
G007993-0	E-Stop	E-stop allows for immediate fuel shutoff and generator shutdown in the event of an emergency.
G007005-0	Wi-Fi LP Fuel Level Monitor	The Wi-Fi enabled LP fuel level monitor provides constant monitoring of the connected LP fuel tank. Monitoring the LP tank's fuel level is an important step in making sure your generator is ready to run during an unexpected power failure. Status alerts are available through a free application to notify when your LP tank is in need of a refill.
G007000-0 (50 amp) G007006-0(100 amp)	Smart Management Module	Smart Management Modules (SMM) are used to optimize the performance of a standby generator. They manage large electrical loads upon startup and shed them to aid in recovery when overloaded. In many cases, using SMM's can reduce the overall size and cost of the system.
A0000018981	Ultrasonic Cleaner Solution	An ultra-concentrated anti-corrosive cleaning solution engineered to reach the smallest cavities to clean the toughest contaminants. This water based formula is non-toxic, biodegradable, safe for both metal and plastic surfaces and is superior in rinsability.
A0000019001	Corrosion Inhibitor & Protectant	A plastic, rubber, leather, and vinyl surface protectant designed for use following a thorough cleaning with the <b>A0000018981</b> Ultrasonic Cleaner Solution. It helps protected surfaces stay clean longer as a dry lubrication, polish, and wax. Aids in snow and grass release and odor control.



WEIGHT DATA				
ENGINE/KW	ENCLOSURE MATERIAL	WEIGHT GENSET ONLY KG [LBS]	WEIGHT SHIPPING SKID KG [LBS]	SHIPPING WEIGHT KG [LBS]
4.5L/48KW	AL	808 [1781]	51 [112]	859 [1893]

SERVICE ITEM	4.5L
OIL FILL CAP	LEFT SIDE
OIL DIP STICK	LEFT SIDE
OIL FILTER	LEFT SIDE
OIL DRAIN HOSE	RIGHT SIDE
RADIATOR DRAIN HOSE	RIGHT SIDE
COOLANT RECOVERY BOTTLE	RIGHT SIDE
RADIATOR FILL CAP	ROOF TOP
AIR CLEANER ELEMENT	LEFT SIDE
SPARK PLUGS	LEFT SIDE
MUFFLER	SEE NOTE 11
DRIVE BELT	EITHER SIDE
BATTERY	LEFT SIDE

NOTES:

- MINIMUM RECOMMENDED CONCRETE PAD SIZE IS 6" OFFSET OF OVERALL LENGTH AND WIDTH OF GENERATOR. {1193.8 (47") WIDE X 2423.2 (95.4") LONG}. REFERENCE INSTALLATION GUIDE SUPPLIED WITH THE UNIT FOR CONCRETE PAD GUIDELINES. REFERENCE MANUFACTURER'S SPECIFICATIONS IF USING ENGINEERED, PREFABRICATED SLABS.
- ALLOW SUFFICIENT ROOM ON ALL SIDES OF THE GENERATOR FOR MAINTENANCE AND SERVICING. THIS UNIT MUST BE INSTALLED IN ACCORDANCE WITH CURRENT APPLICABLE NFPA 37 AND NFPA 70 STANDARDS AS WELL AS ANY OTHER FEDERAL, STATE, AND LOCAL CODES.
- CONTROL PANEL / CIRCUIT BREAKER INFORMATION:
  - SEE SPECIFICATION SHEET OR OWNERS MANUAL
  - ACCESSIBLE THROUGH CUSTOMER ACCESS ASSEMBLY DOOR ON REAR OF GENERATOR.
- REMOVE THE REAR ENCLOSURE COVER PANEL TO ACCESS THE STUB-UP AREAS AS FOLLOWS:
  - HIGH VOLTAGE CONNECTION INCLUDING AC LOAD LEAD CONDUIT CONNECTION NEUTRAL CONNECTION, BATTERY CHARGER 120 VOLT AC (0.5 AMP MAX) CONNECTION.
  - LOW VOLTAGE CONNECTION INCLUDING TRANSFER SWITCH CONTROL WIRES.
- CENTER OF GRAVITY AND WEIGHT MAY CHANGE DUE TO UNIT OPTIONS.
- BOTTOM OF GENERATOR SET MUST BE ENCLOSED TO PREVENT PEST INTRUSION AND RECIRCULATION OF DISCHARGE AIR AND/OR IMPROPER COOLING AIR FLOW.
- REFERENCE OWNERS MANUAL FOR LIFTING WARNINGS.
- MOUNTING BOLTS OR STUDS TO MOUNTING SURFACE SHALL BE 5/8-11 GRADE 5 (USE STANDARD SAE TORQUE SPECS)
- MUST ALLOW FREE FLOW OF INTAKE AIR, DISCHARGE AIR AND EXHAUST. SEE SPEC SHEET FOR MINIMUM AIR FLOW AND MAXIMUM RESTRICTION REQUIREMENTS.
- GENERATOR MUST BE INSTALLED SUCH THAT FRESH COOLING AIR IS AVAILABLE AND THAT DISCHARGE AIR FROM RADIATOR IS NOT RECIRCULATED.
- EXHAUST MUFFLER ENCLOSED WITHIN GENERATOR ENCLOSURE, REMOVE FRONT PANEL TO ACCESS.

RADIATOR/EXHAUST DISCHARGE AIR (BOTH SIDES) ↑

AIR INTAKE (BOTH SIDES) ↓

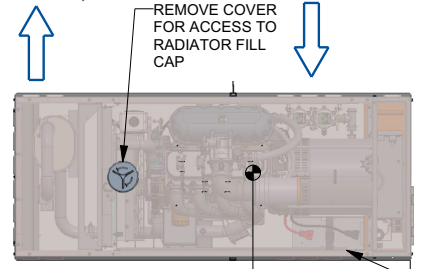

TOP VIEW

843 [33]

CENTER OF GRAVITY (SEE NOTE 5)

REFERENCE OWNERS MANUAL FOR PERIODIC REPLACEMENT PARTS LIST

BATTERY 12V GROUP 27F NEGATIVE GROUND P/N G058665

← RADIATOR/EXHAUST DISCHARGE AIR

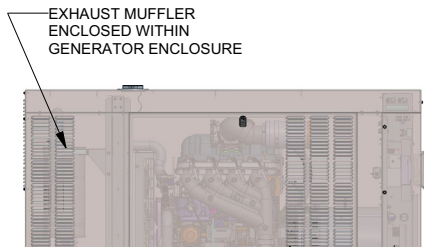

58 [2.3] TYP

47 [1.8]

2026 [79.8] TYP

2119 [83.4] OVERALL LENGTH

LEFT SIDE VIEW

CIRCUIT BREAKER SEE NOTE 3

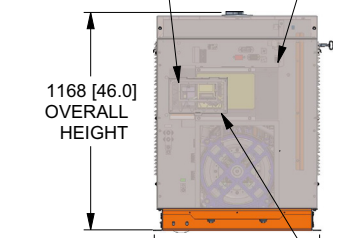

1168 [46.0] OVERALL HEIGHT

888 [35.0] OVERALL WIDTH

REAR VIEW

REAR ENCLOSURE COVER PANEL SEE NOTE 4

CUSTOMER ACCESS ASSEMBLY, CONTROL PANEL ACCESS BATTERY CHARGER LOCATED WITHIN SEE NOTE 4

1212 [47.7] DOOR TYP

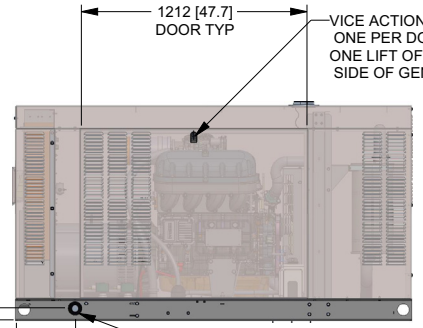

65 [2.6]

318 [12.5]

FUEL LINE CONNECTION 1-1/4" NPT FEMALE TEE THROUGH BASEFRAME OPENING

RIGHT SIDE VIEW

VICE ACTION LATCH ONE PER DOOR ONE LIFT OFF DOOR PER SIDE OF GENERATOR

DIMENSIONS: MM [INCH]

\*NOTE:  
STUB-UP AREA FOR HIGH AND LOW  
VOLTAGE CONNECTIONS, CIRCUIT BREAKER,  
NEUTRAL AND CUSTOMER CONNECTION OPENING.

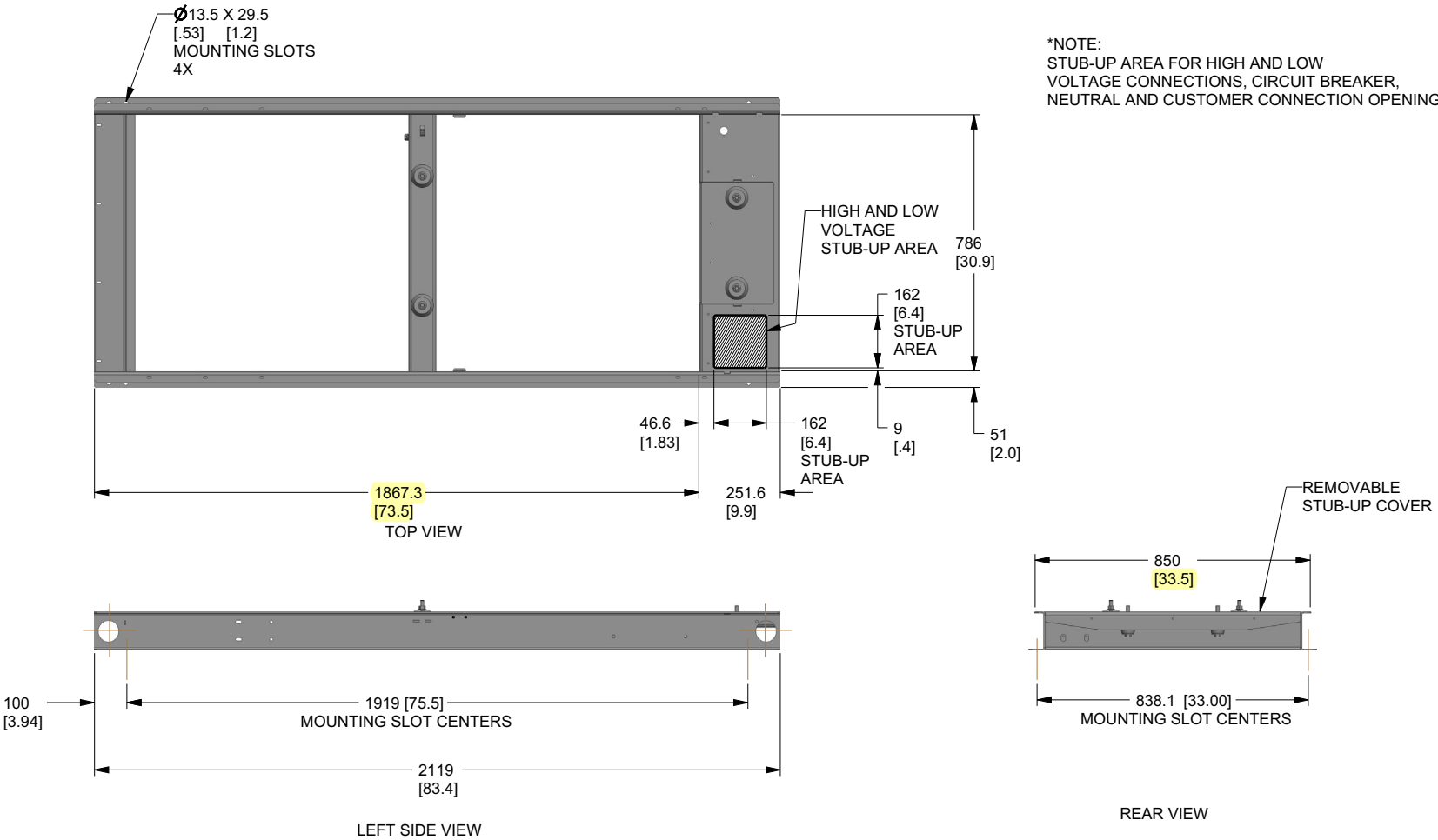

DIMENSIONS: MM [INCH]

TRI-COUNTY, BIG PINE, STATHAM HALL  
400A, 120/240V, SINGLE PHASE

## Automatic Transfer Switches

## Service and non-Service rated Automatic Smart Transfer Switches

100 - 400 Amps, Single Phase

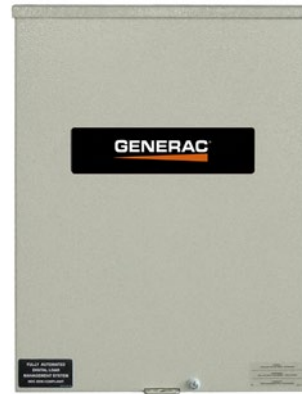
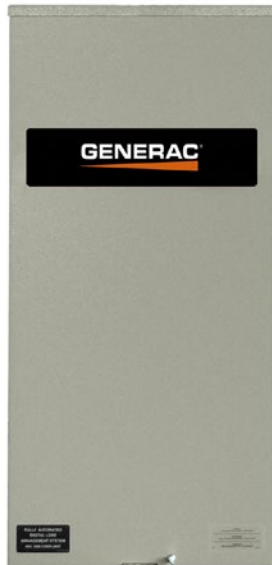

\*Built in the USA using domestic and foreign parts

\*CUL only applies to non-service rated switches

### Description

Generac Automatic Transfer Switches are designed for use with single phase generators that utilize an Evolution™ or Nexus™ Controller. The 100, 200, and 400 amp open transition switches are available in single phase in both service equipment rated and non-service equipment rated configurations. The 150 and 300 amp open transition switches are only available in a service rated equipment configuration.

### Standard Features

Service rated (RTSW) Generac Automatic Transfer Switches are housed in an aluminum NEMA/UL Type 3R enclosure\*, with electrostatically applied and baked powder paint. The Heavy Duty Generac Contactor is a UL recognized device, designed for years of service. The controller at the generator handles all the timing, sensing, exercising functions, and transfer commands. All switches are covered by a 5 year limited warranty.

\* Non-service rated (RTSC) switches are housed in a steel enclosure.

### DPM Technology

Through the use of digital power technology (DPM), these switches have the capability to manage up to 4 individual HVAC (24 VAC controlled) loads with no additional hardware. When used in tandem with Smart Management Modules, up to 8 more loads can be managed as well, providing the most installation efficient power management options available.

# 100-400 Amps, Single Phase

# Automatic Smart Transfer Switches

## Functions

All timing and sensing functions originate in the generator controller

Utility voltage drop-out.....	<60%
Timer to generator start.....	10 second factory set, adjustable between 2-1500 seconds by a qualified dealer*
Engine warm up delay.....	5 seconds
Standby voltage sensor.....	60% for 5 seconds
Utility voltage pickup.....	>80%
Re-transfer time delay.....	15 seconds
Engine cool-down timer.....	60 seconds
Exerciser.....	12 minutes every 7 days

The transfer switch can be operated manually without power applied.

\*When used in conjunction with units utilizing Evolution™ controls

## Specifications

Model	RTSC100A3	RTSW100A3	RTSW150A3	RTSC200A3	RTSW200A3	RTSW300A3	RTSC400A3	RTSW400A3
Amps	100	100	150	200	200	300	400	400
Voltage	120/240, 1Ø	120/240, 1Ø	120/240, 1Ø	120/240, 1Ø	120/240, 1Ø	120/240, 1Ø	120/240, 1Ø	120/240, 1Ø
Load Transition Type (Automatic)	Open Transition	Open Transition Service Rated	Open Transition Service Rated	Open Transition	Open Transition Service Rated	Open Transition Service Rated	Open Transition	Open Transition Service Rated
Enclosure Type	NEMA/UL 3R	NEMA/UL 3R	NEMA/UL 3R	NEMA/UL 3R	NEMA/UL 3R	NEMA/UL 3R	NEMA/UL 3R	NEMA/UL 3R
UL Rating	UL/CUL	UL	UL	UL/CUL	UL	UL	UL/CUL	UL
Withstand Rating (Amps)	10,000	10,000	22,000	10,000	22,000	22,000	22,000	22,000
Lug Range	1/0 - #14		250 MCM - #6			600 MCM - #4 or 1/0 - 250 MCM		

## Dimensions

Model		RTSC100A3	RTSW100A3	RTSW150A3	RTSC200A3	RTSW200A3	RTSW300A3	RTSC400A3	RTSW400A3
Height (in./mm)	H1	17.24/437.9	17.24/437.9	26.75/679.4	17.24/437.9	26.75/679.4	42.91/1089.9	31.25/793.8	42.91/1089.9
	H2	20/508	20/508	30/762	20/508	30/762	48/1219.2	36/914.4	48/1219.2
Width (in./mm)	W1	12.5/317.5	12.5/317.5	10.5/266.7	12.5/317.5	10.5/266.7	16.69/423.9	19.18/487.2	16.69/423.9
	W2	14.6/370.8	14.6/370.8	13.5/342.9	14.6/370.8	13.5/342.9	21.82/554.2	24/609.6	21.82/554.2
Depth (in./mm)		7.09/180.1	7.09/180.1	6.3/160.1	7.09/180.1	6.3/160.1	10.06/255.5	10.06/255.5	10.06/255.5
Weight (lbs./kilos)		20/9.07	22.5/10.21	39/17.69	20/9.07	39/17.69	140/63.5	133/60.33	140/63.5

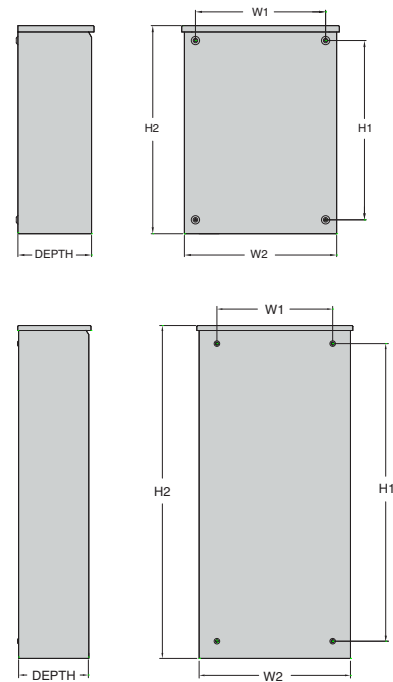

### **Venue #3 – Courthouse, 168 N Edwards Street, Independence, CA**

This scope of work includes all work necessary, whether reflected in this scope of work or not, to complete the installation of a Generac RG048 48 kW, 3 Phase generator and Generac 200 Amp automatic transfer switch (ATS), both of which will be provided by Inyo County Public Works.

This scope of work involves the sawcutting, removal, and offhaul of asphalt of the same shape as the 8" concrete pad, excavation for a concrete generator pad, formwork, rebar, concrete materials, concrete placement and finishing, concrete blankets for subgrade and concrete frost protection, tapping into and piping from the existing propane line including furnishing and installing a propane regulator, setting of the generator on the concrete pad including any crane costs, installation of surface mounted conduit for generator power, battery charger circuit, and control wiring, interception of the existing subfeed from main breaker to distribution panel and the installation of the automatic transfer switch.

Contractor is responsible for the design of all work, and must submit a plan, single line drawing, and product data sheets with respect to conduit size and material, conduit routing, conductor and breaker sizing, grounding or bonding, etc. for approval by the Building Official and the County Engineer prior to commencing work.













PANEL: CH LV-5				VOLTAGE: 120/208			
LOCATION: Records office				TYPE: Square D 90			
AIC RATING: 10,000				PHASE: 3		WIRE: 4	
DESCRIPTION	BREAKER			BREAKER			DESCRIPTION
	T	POLE	#	#	POLE	T	
Right hand Duplex in Quad below panel	20	1	1	2	1	20	Left hand Duplex in Quad below panel
/			3	4			/
/			5	6			/
/ SPACE			7	8			/ SPACE
/			9	10			/
/			11	12			/
/			13	14	2	20	Water Heater in Records office
South wall Receptacles wire mtd	20		15	16	2	20	Lunch room Recep. East wall
South wall Receptacles wire mtd			17	18	2	20	NE. office wire mtd receptacle/court file room
RECP. COURT RM SE WALL			19	20	2	20	NE. office wire mtd receptacle/court file room
RECP. COURT RM N NEWALL			21	22			and north wall/northwest office window cooler
Lunch room Recep. west wall			23	24			Quad recep. west wall north office
East wall Quad north of window			25	26			Duplex recep. west wall by window/sandals
Duplex by doorway/fridge			27	28			Quad recep. south wall Recorder
3/4 ENT south into north office ?	20		29	30	20	20	Quad recep. south wall Recorder
			31	32			
			33	34			
			35	36			
			37	38			
			39	40			
			41	42			

Feed From CH-LV-HSP	
BUSS RATING	225
MAIN CB RATING	100A
MOUNTING	surface

AMP TEST \*

BL - 3.5

R .7

BCU .6

W 2.8





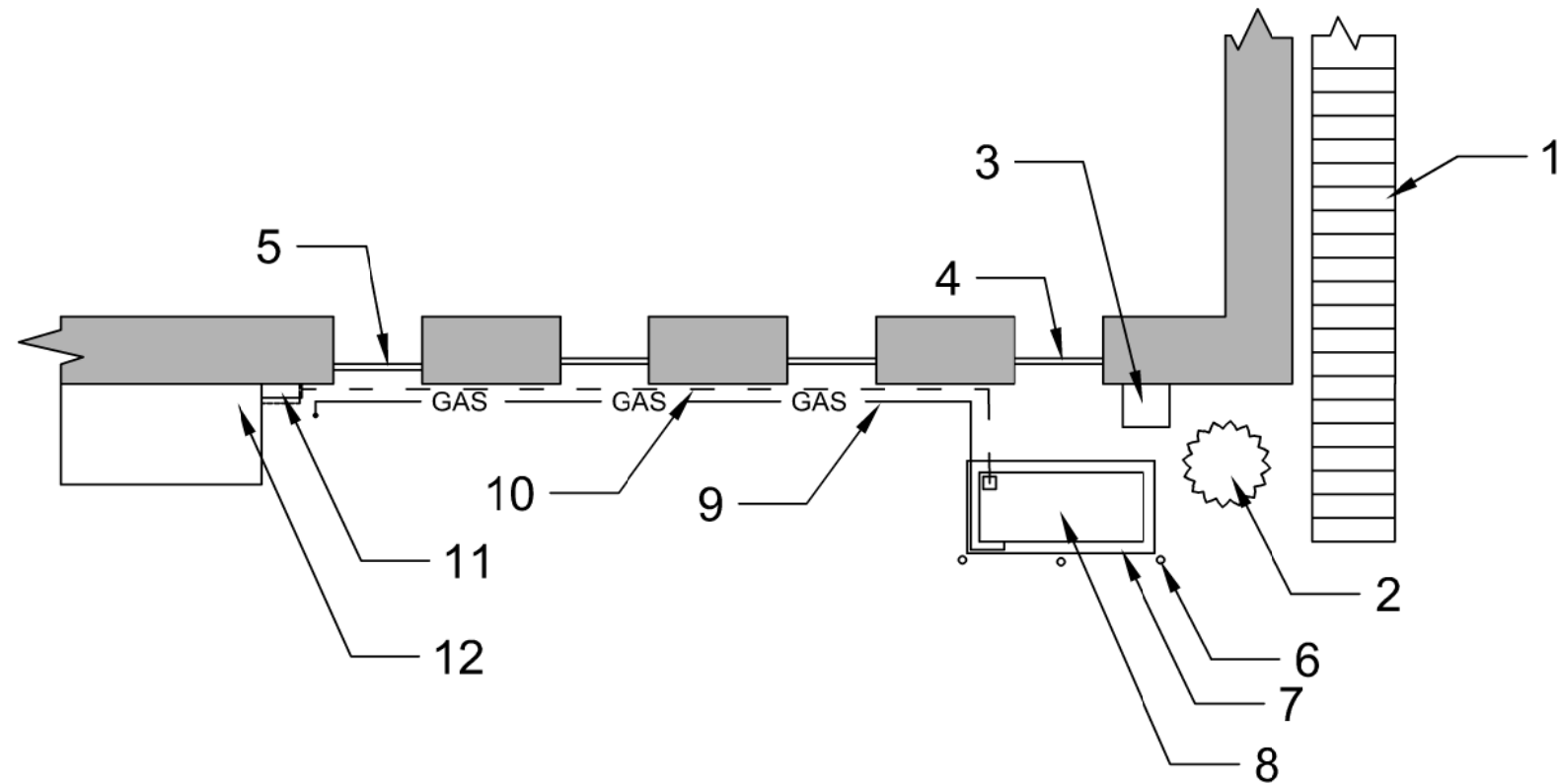

## LEGEND

1. Stairway (E)
2. Tree (E)
3. Electrical box (E)
4. Window, typical (E) - Secure closed within 10' of generator exhaust
5. Mechanical Room louver (E)
6. 4" Pipe Bollard, 3 Each (N)
7. Concrete generator pad (N)
8. Generac RG48 generator (N) - County furnished, Contractor Installed
9. Above-grade propane line w/ pressure regulator (N) - bolted to wall below windows
10. Generator power circuit, block heater & battery charger circuits, & control wire circuits (N) - bolted to wall below windows
11. Automatic Transfer Switch (N) - County furnished, Contractor installed
12. Panel CH-LV5 subfeed breaker

**Inyo County Courthouse  
General Arrangement Layout**

Inyo County Public Works  
Design: GLW 10/20/2020  
Scale:  $\frac{1}{8}" = 1' - 0"$ , @ 11" x 17"

## Protector® Series

### PROTECTOR® SERIES Standby Generators Liquid-Cooled Gaseous Engine

Courthouse, RG48KW

1 of 7

#### INCLUDES:

- Two-Line LCD Multilingual Digital Evolution™ Controller (English/Spanish/French/Portuguese) With External Viewing Window for Easy Indication of Generator Status and Breaker Position.
- SwRI® listed (NFPA37, clause 4.1.4.1.2) Generator can be installed a minimum 18" distance from combustible walls\*
- Isochronous Electronic Governor
- Sound Attenuated Enclosure
- Closed Coolant Recovery System
- Smart Battery Charger
- UV/Ozone Resistant Hoses
- ±1% Voltage Regulation
- Field Convertible Fuel Type With No Mechanical Adjustment Required.
- 5 Year Limited Warranty
- UL 2200 Listed

\*Only if located away from doors, windows, and fresh air intakes, and unless otherwise directed by local codes. Please review install guide for more details.

Standby Power Rating

Model RG048 (Aluminum - Bisque) - 48 kW 60 Hz



QUIET-TEST™

\*Assembled in the USA using domestic and foreign parts

Meets EPA Emission Regulations

## FEATURES

- **INNOVATIVE DESIGN & PROTOTYPE TESTING** are key components of GENERAC'S success in "IMPROVING POWER BY DESIGN." But it doesn't stop there. Total commitment to component testing, reliability testing, environmental testing, destruction and life testing, plus testing to applicable CSA, NEMA, EGSA, and other standards, allows you to choose GENERAC POWER SYSTEMS with the confidence that these systems will provide superior performance.
- **TEST CRITERIA:**
  - ✓ **PROTOTYPE TESTED**
  - ✓ **SYSTEM TORSIONAL TESTED**
  - ✓ **NEMA MG1-22 EVALUATION**
  - ✓ **MOTOR STARTING ABILITY**
- **SOLID-STATE, FREQUENCY COMPENSATED VOLTAGE REGULATION.** This state-of-the-art power maximizing regulation system is standard on all Generac models. It provides optimized FAST RESPONSE to changing load conditions and MAXIMUM MOTOR STARTING CAPABILITY by electronically torque-matching the surge loads to the engine. Digital voltage regulation at ±1%.
- **SINGLE SOURCE SERVICE RESPONSE** from Generac's extensive dealer network provides parts and service know-how for the entire unit, from the engine to the smallest electronic component.
- **GENERAC TRANSFER SWITCHES.** Long life and reliability are synonymous with GENERAC POWER SYSTEMS. One reason for this confidence is the GENERAC product line is offered with its own transfer systems and controls for total system compatibility.

### 48 kW

#### GENERATOR SPECIFICATIONS

Type	Synchronous
Rotor Insulation Class	F (48 kW)
Stator Insulation Class	H
Telephone Interference Factor (TIF)	<50
Alternator Output Leads 1-Phase	4 wire
Alternator Output Leads 3-Phase	6 wire
Bearings	Sealed Ball
Coupling	Flexible Disc
Excitation System	Direct

#### VOLTAGE REGULATION

Type	Electronic
Sensing	Single Phase
Regulation	± 1%

#### GOVERNOR SPECIFICATIONS

Type	Electronic
Frequency Regulation	Isochronous
Steady State Regulation	± 0.25%

#### ELECTRICAL SYSTEM

Battery Charge Alternator	12 Volt 30 Amp
Static Battery Charger	2.5 Amp
Recommended Battery (battery not included)	Group 27F (48kW), 725CCA
System Voltage	12 Volts

#### GENERATOR FEATURES

<p>Revolving field heavy duty generator          Directly connected to the engine          Operating temperature rise 120 °C above a 40 °C ambient          Class H insulation is NEMA rated          Class F insulation is NEMA rated          All models fully prototyped tested</p>
------------------------------------------------------------------------------------------------------------------------------------------------------------------------------------------------------------------------------------------------------------------------------------------------------------

#### ENCLOSURE FEATURES

Aluminum weather protective enclosure	Ensures protection against mother nature. Electrostatically applied textured epoxy paint for added durability.
Enclosed critical grade muffler	Quiet, critical grade muffler is mounted inside the unit to prevent injuries.
Small, compact, attractive	Makes for an easy, eye appealing installation.
SAE	Sound attenuated enclosure ensures quiet operation.

#### ENGINE SPECIFICATIONS: 48 kW

Make	Generac
Model	Inline 4 cylinder
Cylinders	4
Displacement (Liters)	4.5
Bore (in/mm)	4.5/114.3
Stroke (in/mm)	4.25/107.95
Compression Ratio	9.9:1
Intake Air System	Naturally Aspirated
Lifter Type	Hydraulic

#### ENGINE LUBRICATION SYSTEM

Oil Pump Type	Gear
Oil Filter Type	Full Flow Spin-On Cartridge
Crankcase Capacity (qt/l)	11.6/11 (48 kW)

#### ENGINE COOLING SYSTEM

Type	Ethylene Glycol 50/50 Mix
Water Pump	Belt-Driven
Fan Speed (rpm)	2,100
Fan Diameter (in/mm)	20
Fan Mode	Pusher

#### FUEL SYSTEM

Fuel Type	Natural Gas, Propane Vapor
Fuel Shut Off Solenoid	Standard
Operating Fuel Pressure	3.5-14 Water Column/9-26 mm HG
LP Fuel Pressure	7 - 14" Water Column
NG Fuel Pressure	3.5 - 14" Water Column

### 48 kW

#### GENERATOR OUTPUT VOLTAGE/kW - 60 Hz

		kW LPG	Amp LPG	kW Nat. Gas	Amp Nat. Gas	CB Size (Both)
RG048	120/240 V, 1Ø, 1.0 pf	48	200	48	200	200
	120/208 V, 3Ø, 0.8 pf	48	167	48	167	175
	120/240 V, 3Ø, 0.8 pf	48	144	48	144	150
	277/480 V, 3Ø, 0.8 pf	48	72	48	72	80

#### SURGE CAPACITY IN AMPS

		Voltage Dip @ < .4 pf	
		15%	30%
		RG048	
	120/240 V, 1Ø	100	300
	120/208 V, 3Ø	118	242
	120/240 V, 3Ø	97	189
	277/480 V, 3Ø	63.6	122.8

#### ENGINE FUEL CONSUMPTION

		Natural Gas		Propane		
		(ft³/hr)	(m³/hr)	(gal/hr)	(ft³/hr)	(l/hr)
		RG048				
	Exercise cycle	—	—	—	—	—
	25% of rated load	201	5.7	2.88	104.7	10.9
	50% of rated load	336	9.5	4.16	151.3	15.7
	75% of rated load	447	12.7	5.28	192	20
	100% of rated load	604	17.1	6.61	240.4	25

Note: Fuel pipe must be sized for full load.

For Btu content, multiply ft³/hr x 2520 (LP) or ft³/hr x 1000 (NG)

For megajoule content, multiply m³/hr x 93.15 (LP) or m³/hr x 37.26 (NG)

Refer to "Emissions Data Sheets" for maximum fuel flow for EPA and SCAQMD permitting purposes.

STANDBY RATING: Standby ratings apply to installations served by a reliable utility source. The standby rating is applicable to varying loads for the duration of a power outage. There is no overload capability for this rating. Ratings are in accordance with ISO-3046-1. Design and specifications are subject to change without notice.

### 48 kW

#### ENGINE COOLING

48 kW

Air Flow (inlet air including alternator and combustion air in cfm/cmm)	2,829/80.1
System Coolant Capacity (gal/liters)	2.9/11
Heat Rejection to Coolant (BTU per hr/MJ per hr)	201,060
Maximum Operation Air Temperature on Radiator (°C/°F)	60/150
Maximum Ambient Temperature (°C/°F)	50/140

#### COMBUSTION REQUIREMENTS

Flow at Rated Power (scfm/cmm)	92.7/2.6
--------------------------------	----------

#### SOUND EMISSIONS

Sound Output in dB(A) at 23 ft (7 m) With Generator in Exercise Mode*	68
Sound Output in dB(A) at 23 ft (7 m) With Generator Operating at Normal Load*	70

#### EXHAUST

Exhaust Flow at Rated Output (scfm/cmm)	104/10.6
Exhaust Temperature at Muffler Outlet (°C/°F)	507/945

#### ENGINE PARAMETERS

Rated Synchronous rpm	1,800
-----------------------	-------

#### POWER ADJUSTMENT FOR AMBIENT CONDITIONS

Temperature Deration ..... 3% for every 10 °C above 25 °C or 1.65% for every 10 °F above 77 °F  
 Altitude Deration.....1% for every 100 m above 183 m or 3% for every 1000 ft above 600 ft

#### CONTROLLER FEATURES

Two-Line Plain Text LCD Display..... Simple user interface for ease of operation.  
 Mode Switch: Auto ..... Automatic Start on Utility failure. 7 day exerciser  
                   Off ..... Stops unit. Power is removed. Control and charger still operate.  
                   Manual ..... Start with starter control, unit stays on. If utility fails, transfer to load takes place.  
 Programmable Start Delay Between 10-30 Seconds ..... 10 sec standard  
 Engine Start Sequence ..... Cyclic cranking: 16 sec on, 7 rest (90 sec maximum duration)  
 Engine Warm-up ..... 5 sec  
 Engine Cool-Down ..... 1 min  
 Starter Lock-Out ..... Starter cannot re-engage until 5 sec after engine has stopped.  
 Smart Battery Charger ..... Standard  
 Automatic Voltage Regulation With Over and Under Voltage Protection ..... Standard  
 Automatic Low Oil Pressure Shutdown ..... Standard  
 Overspeed Shutdown ..... Standard, 72 Hz  
 High Temperature Shutdown ..... Standard  
 Overcrank Protection ..... Standard  
 Safety Fused ..... Standard  
 Failure to Transfer Protection ..... Standard  
 Low Battery Protection ..... Standard  
 50 Event Run Log ..... Standard  
 Future Set Capable Exerciser ..... Standard  
 Incorrect Wiring Protection ..... Standard  
 Internal Fault Protection ..... Standard  
 Common External Fault Capability ..... Standard  
 Governor Failure Protection ..... Standard



Model #	Product	Description
G0071690	Mobile Link® 4G LTE Cellular Accessory	Generac's Mobile Link allows you to check the status of your generator from anywhere that you have access to an Internet connection from a PC or with any smart device. You will even be notified when a change in the generator's status occurs via e-mail or text message. Note: Harness Adapter Kit required. Available in the U.S. only.
G006478-0	Kit, Adapter Mobile Link L/C (Required for QT and RG Series)	The Harness Adapter Kit is required to make liquid-cooled units compatible with Mobile Link®
G007992-0	Cold Weather Kit	If the temperature regularly falls below 32 °F (0 °C), install a cold weather kit to maintain optimal battery temperature. Kit consists of battery warmer with thermostat built into the wrap.
G007990-0	Extreme Cold Weather Kit	Recommended where the temperature regularly falls below 32 °F (0 °C) for extended periods of time. For liquid cooled units only.
G005651-0	Base Plug Kit	Add base plugs to the base of the generator to keep out debris.
G005703-0 - Bisque	Paint Kit	If the generator enclosure is scratched or damaged, it is important to touch-up the paint to protect from future corrosion. The paint kit includes the necessary paint to properly maintain or touch-up a generator enclosure.
G007991-0	Scheduled Maintenance Kit	The Liquid-Cooled Scheduled Maintenance Kits offer all the hardware necessary to perform complete maintenance on Generac liquid-cooled generators.
G006664-0	Local Wireless Monitor	Completely wireless and battery powered, Generac's wireless remote monitor provides you with instant status information without ever leaving the house.
G006665-0	Wireless Remote Extension Harness	Recommended for use with the Wireless Remote on units up to 60 kW, required for use on units 70 kW or greater.
G007993-0	E-Stop	E-stop allows for immediate fuel shutoff and generator shutdown in the event of an emergency.
G007005-0	Wi-Fi LP Fuel Level Monitor	The Wi-Fi enabled LP fuel level monitor provides constant monitoring of the connected LP fuel tank. Monitoring the LP tank's fuel level is an important step in making sure your generator is ready to run during an unexpected power failure. Status alerts are available through a free application to notify when your LP tank is in need of a refill.
G007000-0 (50 amp) G007006-0(100 amp)	Smart Management Module	Smart Management Modules (SMM) are used to optimize the performance of a standby generator. They manage large electrical loads upon startup and shed them to aid in recovery when overloaded. In many cases, using SMM's can reduce the overall size and cost of the system.
A0000018981	Ultrasonic Cleaner Solution	An ultra-concentrated anti-corrosive cleaning solution engineered to reach the smallest cavities to clean the toughest contaminants. This water based formula is non-toxic, biodegradable, safe for both metal and plastic surfaces and is superior in rinsability.
A0000019001	Corrosion Inhibitor & Protectant	A plastic, rubber, leather, and vinyl surface protectant designed for use following a thorough cleaning with the <b>A0000018981</b> Ultrasonic Cleaner Solution. It helps protected surfaces stay clean longer as a dry lubrication, polish, and wax. Aids in snow and grass release and odor control.

WEIGHT DATA				
ENGINE/KW	ENCLOSURE MATERIAL	WEIGHT GENSET ONLY KG [LBS]	WEIGHT SHIPPING SKID KG [LBS]	SHIPPING WEIGHT KG [LBS]
4.5L/48KW	AL	808 [1781]	51 [112]	859 [1893]

SERVICE ITEM	4.5L
OIL FILL CAP	LEFT SIDE
OIL DIP STICK	LEFT SIDE
OIL FILTER	LEFT SIDE
OIL DRAIN HOSE	RIGHT SIDE
RADIATOR DRAIN HOSE	RIGHT SIDE
COOLANT RECOVERY BOTTLE	RIGHT SIDE
RADIATOR FILL CAP	ROOF TOP
AIR CLEANER ELEMENT	LEFT SIDE
SPARK PLUGS	LEFT SIDE
MUFFLER	SEE NOTE 11
DRIVE BELT	EITHER SIDE
BATTERY	LEFT SIDE

NOTES:

- MINIMUM RECOMMENDED CONCRETE PAD SIZE IS 6" OFFSET OF OVERALL LENGTH AND WIDTH OF GENERATOR. {1193.8 (47") WIDE X 2423.2 (95.4") LONG}. REFERENCE INSTALLATION GUIDE SUPPLIED WITH THE UNIT FOR CONCRETE PAD GUIDELINES. REFERENCE MANUFACTURER'S SPECIFICATIONS IF USING ENGINEERED, PREFABRICATED SLABS.
- ALLOW SUFFICIENT ROOM ON ALL SIDES OF THE GENERATOR FOR MAINTENANCE AND SERVICING. THIS UNIT MUST BE INSTALLED IN ACCORDANCE WITH CURRENT APPLICABLE NFPA 37 AND NFPA 70 STANDARDS AS WELL AS ANY OTHER FEDERAL, STATE, AND LOCAL CODES.
- CONTROL PANEL / CIRCUIT BREAKER INFORMATION:
  - SEE SPECIFICATION SHEET OR OWNERS MANUAL
  - ACCESSIBLE THROUGH CUSTOMER ACCESS ASSEMBLY DOOR ON REAR OF GENERATOR.
- REMOVE THE REAR ENCLOSURE COVER PANEL TO ACCESS THE STUB-UP AREAS AS FOLLOWS:
  - HIGH VOLTAGE CONNECTION INCLUDING AC LOAD LEAD CONDUIT CONNECTION NEUTRAL CONNECTION, BATTERY CHARGER 120 VOLT AC (0.5 AMP MAX) CONNECTION.
  - LOW VOLTAGE CONNECTION INCLUDING TRANSFER SWITCH CONTROL WIRES.
- CENTER OF GRAVITY AND WEIGHT MAY CHANGE DUE TO UNIT OPTIONS.
- BOTTOM OF GENERATOR SET MUST BE ENCLOSED TO PREVENT PEST INTRUSION AND RECIRCULATION OF DISCHARGE AIR AND/OR IMPROPER COOLING AIR FLOW.
- REFERENCE OWNERS MANUAL FOR LIFTING WARNINGS.
- MOUNTING BOLTS OR STUDS TO MOUNTING SURFACE SHALL BE 5/8-11 GRADE 5 (USE STANDARD SAE TORQUE SPECS)
- MUST ALLOW FREE FLOW OF INTAKE AIR, DISCHARGE AIR AND EXHAUST. SEE SPEC SHEET FOR MINIMUM AIR FLOW AND MAXIMUM RESTRICTION REQUIREMENTS.
- GENERATOR MUST BE INSTALLED SUCH THAT FRESH COOLING AIR IS AVAILABLE AND THAT DISCHARGE AIR FROM RADIATOR IS NOT RECIRCULATED.
- EXHAUST MUFFLER ENCLOSED WITHIN GENERATOR ENCLOSURE, REMOVE FRONT PANEL TO ACCESS.

RADIATOR/EXHAUST DISCHARGE AIR (BOTH SIDES) ↑

AIR INTAKE (BOTH SIDES) ↓

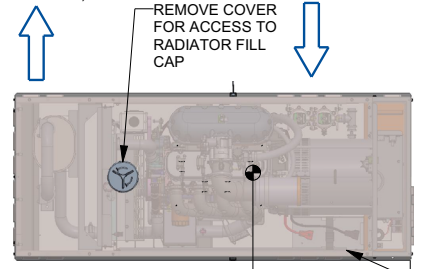

TOP VIEW

843 [33]

CENTER OF GRAVITY (SEE NOTE 5)

REFERENCE OWNERS MANUAL FOR PERIODIC REPLACEMENT PARTS LIST

BATTERY 12V GROUP 27F NEGATIVE GROUND P/N G058665

← RADIATOR/EXHAUST DISCHARGE AIR

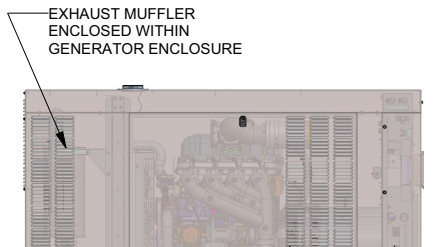

58 [2.3] TYP

47 [1.8]

2026 [79.8] TYP

2119 [83.4] OVERALL LENGTH

LEFT SIDE VIEW

CIRCUIT BREAKER SEE NOTE 3

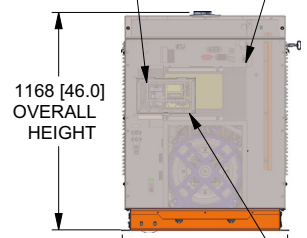

1168 [46.0] OVERALL HEIGHT

888 [35.0] OVERALL WIDTH

REAR VIEW

REAR ENCLOSURE COVER PANEL SEE NOTE 4

CUSTOMER ACCESS ASSEMBLY, CONTROL PANEL ACCESS BATTERY CHARGER LOCATED WITHIN SEE NOTE 4

1212 [47.7] DOOR TYP

VICE ACTION LATCH ONE PER DOOR ONE LIFT OFF DOOR PER SIDE OF GENERATOR

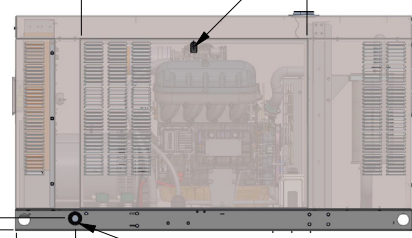

65 [2.6]

318 [12.5]

FUEL LINE CONNECTION 1-1/4" NPT FEMALE TEE THROUGH BASEFRAME OPENING

RIGHT SIDE VIEW

DIMENSIONS: MM [INCH]

\*NOTE:  
STUB-UP AREA FOR HIGH AND LOW  
VOLTAGE CONNECTIONS, CIRCUIT BREAKER,  
NEUTRAL AND CUSTOMER CONNECTION OPENING.

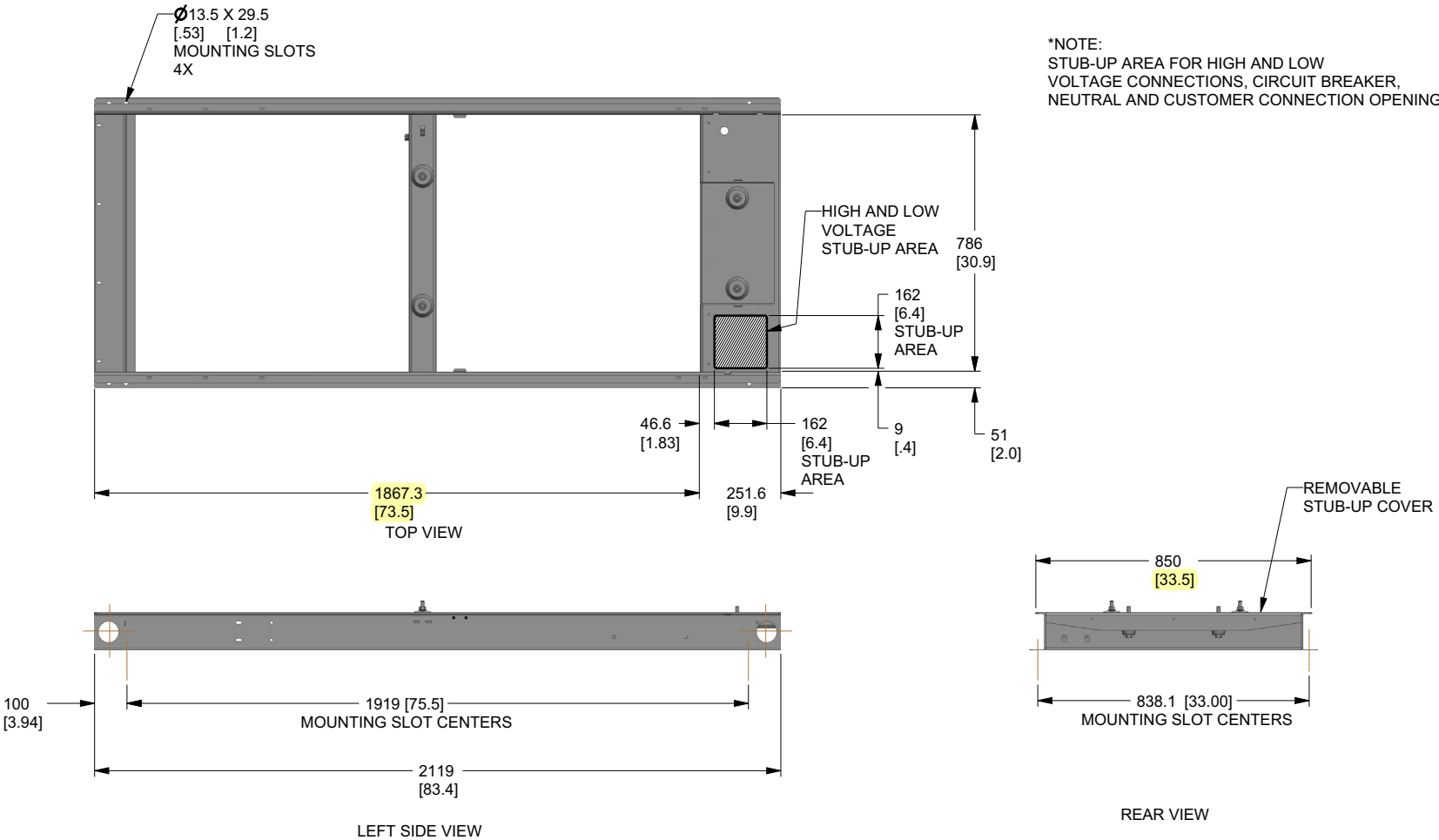

DIMENSIONS: MM [INCH]

100-400 Amps

COURTHOUSE  
200A, 120/208V, 3 PHASE

**GENERAC®**

**Non-Service Rated  
Automatic Transfer Switches**

100-400 Amps

1 of 2

100 - 400 Amps, Three Phase

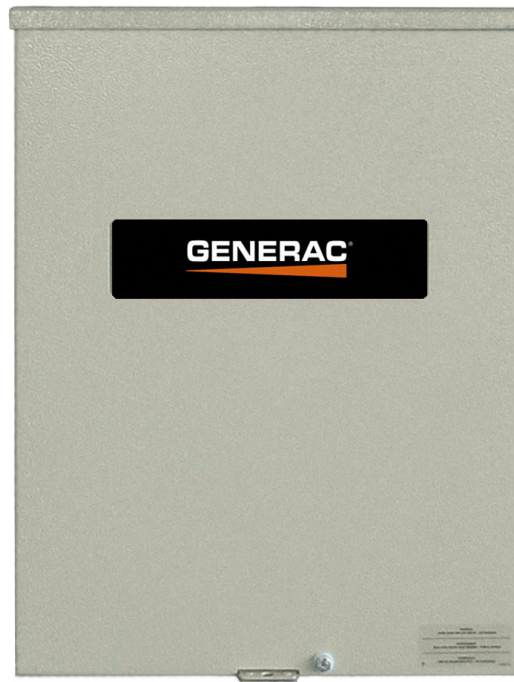

## DESCRIPTION

All non-service rated switches are available in 120/208 3 $\phi$ , 120/240 3 $\phi$ , and 277/480 3 $\phi$ . All switches are open transition.

## STANDARD FEATURES

All non-service rated transfer switches are housed in a steel NEMA/UL Type 3R enclosure, with electrostatically applied and baked powder paint. The Heavy Duty Generac Contactor is a UL recognized device, designed for years of service. The controller at the generator handles all the timing, sensing, exercising functions, and transfer commands.

**GENERAC®**



# 100-400 Amps

# Non-Service Rated Transfer Switches

## Functions

All timing and sensing functions originate in the generator controller

Utility voltage drop-out.....	<60%
Timer to generator start.....	10 second factory set, adjustable between 10-30 seconds
Engine warm up delay.....	5 seconds
Standby voltage sensor.....	.60% for 5 seconds
Utility voltage pickup.....	>80%
Re-transfer time delay.....	15 seconds
Engine cool-down timer.....	60 seconds
Exerciser.....	12 minutes every 7 days*

\*Function of the controller

The transfer switch can be operated manually without power applied.

## Specifications

Model	RTSN100G3	RTSN100J3	RTSN100K3	RTSN200G3	RTSN200J3	RTSN200K3	RTSN400G3	RTSN400J3	RTSN400K3
Amps	100			200			400		
Voltage	120/208 3Ø	120/240 3Ø	277/480 3Ø	120/208 3Ø	120/240 3Ø	277/480 3Ø	120/208 3Ø	120/240 3Ø	277/480 3Ø
Load Transition Type (Automatic)	Open Transition								
Enclosure Type	NEMA 3R								
Withstand Rating (Amps)	14,000	14,000	14,000	25,000	25,000	25,000	35,000	35,000	35,000
Lug Range	2/0 - #6			400 MCM - #4			600 MCM - #4 or 1/0 - 250 MCM		

## Features

- Electrically operated, mechanically-held contacts for fast, positive connections.
- Rated for all classes of load, 100% equipment rated, both inductive and resistive.
- 160 millisecond transfer time.
- Single coil design.
- Main contacts are silver plated or silver alloy to resist welding and sticking.
- NEMA 3R (indoor/outdoor rated) steel enclosure is standard.
- Limited Five Year Warranty.

## Dimensions

Model	Height (in./mm)		Width (in./mm)		Depth (in./mm)	Weight (lbs./kilos)
	H1	H2	W1	W2		
RTSN100G3	19.3/490.2	24.1/612.1	16.9/429.3	20.2/513.1	7.1/180.3	65/29.48
RTSN100J3	19.3/490.2	24.1/612.1	16.9/429.3	20.2/513.1	7.1/180.3	57/25.85
RTSN100K3	31.3/795	36.1/916.9	19.2/487.7	24/609.6	10/254	135/61.24
RTSN200G3	19.3/490.2	24.1/612.1	16.9/429.3	20.2/513.1	7.1/180.3	48/21.77
RTSN200J3	19.3/490.2	24.1/612.1	16.9/429.3	20.2/513.1	7.1/180.3	65/29.48
RTSN200K3	43/1092.2	48.1/1221.7	25/635	30.1/764.5	13.1/332.7	105/47.63
RTSN400G3	31.3/795	36.1/916.9	19.2/487.7	24/609.6	10/254	160/72.57
RTSN400J3	31.3/795	36.1/916.9	19.2/487.7	24/609.6	10/254	133/60.33
RTSN400K3	43/1092.2	48.1/1221.7	25/635	30.1/764.5	13.1/332.7	133/60.33

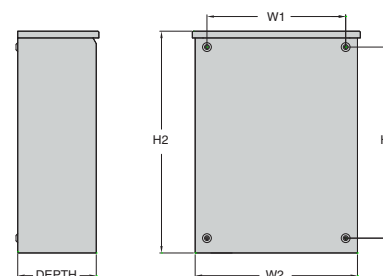

#### **Venue #4 – Annex Building, 168 N Edwards Street, Independence, CA**

This scope of work includes all work necessary, whether reflected in this scope of work or not, to complete the installation of a Generac QT150 150 kW, 3 Phase generator and Generac 600 Amp automatic transfer switch (ATS), both of which will be provided by Inyo County Public Works.

This scope of work involves the sawcutting and removal of concrete as required for conduit runs from the ATS to the generator, pouring back concrete from areas removed, concrete blankets for subgrade and concrete frost protection, tapping into and piping from the existing propane line including furnishing and installing a propane regulator, setting of generator on concrete pad including any crane costs, installation of below grade and surface mounted conduit for generator power, battery charger circuit, block heater circuits, data conduit, and control wiring, interception of the existing subfeed from the transformer to Panel X, and the installation of the automatic transfer switch. Contractor is responsible for the design of all work, and must submit a plan, single line drawing, and product data sheets with respect to conduit size and material, conduit routing, conductor and breaker sizing, grounding or bonding, etc. for approval by the Building Official and the County Engineer prior to commencing work.











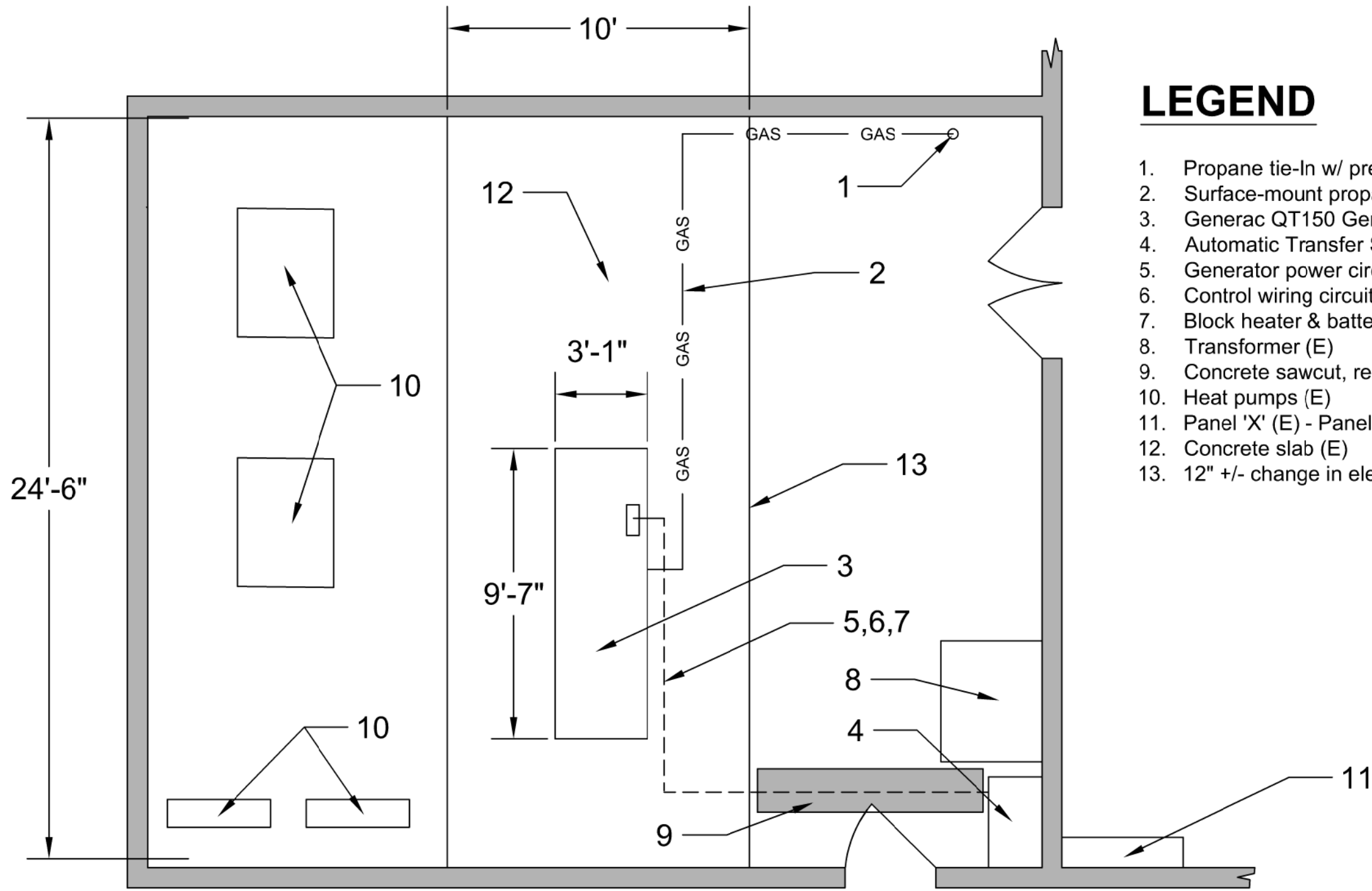

## LEGEND

1. Propane tie-In w/ pressure regulator (N)
2. Surface-mount propane line (N)
3. Generac QT150 Generator (N) - County Furnished, Contractor Installed
4. Automatic Transfer Switch (N) - County Furnished, Contractor Installed
5. Generator power circuit (N)
6. Control wiring circuit (N)
7. Block heater & battery charger circuit (N)
8. Transformer (E)
9. Concrete sawcut, removal, and pour back (N)
10. Heat pumps (E)
11. Panel 'X' (E) - Panel to be powered by Automatic Transfer Switch
12. Concrete slab (E)
13. 12" +/- change in elevation (E)

**Annex Building  
General Arrangement Layout**

Inyo County Public Works  
 Design: GLW 10/20/2020  
 Scale: 1/4" = 1' - 0", @ 11" x 17"

## Standby Generators

### Standby Generators Liquid-Cooled Gaseous Engine

#### INCLUDES:

- Two Line LCD Tri-Lingual Digital Nexus™ Controller
- Isochronous Electronic Governor
- Sound Attenuated Enclosure
- Closed Coolant Recovery System
- Smart Battery Charger
- UV/Ozone Resistant Hoses
- ±1% Voltage Regulation
- Natural Gas or LP Operation
- 2 Year Limited Warranty
- UL 2200 Listed

#### Standby Power Rating

- Model QT070 (Aluminum - Bisque) - 70 kW 60 Hz
- Model QT080 (Aluminum - Bisque) - 80 kW 60 Hz
- Model QT100 (Aluminum - Bisque) - 100 kW 60 Hz
- Model QT130 (Aluminum - Bisque) - 130 kW 60 Hz
- Model QT150 (Aluminum - Bisque) - 150 kW 60 Hz



Meets EPA Emission Regulations

70, 100, 130 & 150 kW meet CA/MA emissions requirement with optional catalyst  
80 kW not for sale in CA/MA

## FEATURES

- **INNOVATIVE DESIGN & PROTOTYPE TESTING** are key components of GENERAC'S success in "IMPROVING POWER BY DESIGN." But it doesn't stop there. Total commitment to component testing, reliability testing, environmental testing, destruction and life testing, plus testing to applicable CSA, NEMA, EGSA, and other standards, allows you to choose GENERAC POWER SYSTEMS with the confidence that these systems will provide superior performance.
- **TEST CRITERIA:**
  - ✓ PROTOTYPE TESTED
  - ✓ SYSTEM TORSIONAL TESTED
  - ✓ NEMA MG1-22 EVALUATION
  - ✓ MOTOR STARTING ABILITY
- **SOLID-STATE, FREQUENCY COMPENSATED VOLTAGE REGULATION.** This state-of-the-art power maximizing regulation system is standard on all Generac models. It provides optimized FAST RESPONSE to changing load conditions and MAXIMUM MOTOR STARTING CAPABILITY by electronically torque-matching the surge loads to the engine. Digital voltage regulation at ±1%.
- **SINGLE SOURCE SERVICE RESPONSE** from Generac's extensive dealer network provides parts and service know-how for the entire unit, from the engine to the smallest electronic component.
- **GENERAC TRANSFER SWITCHES.** Long life and reliability are synonymous with GENERAC POWER SYSTEMS. One reason for this confidence is that the GENERAC product line includes its own transfer systems and controls for total system compatibility.

## 70 • 80 • 100 • 130 • 150 kW

## application &amp; engineering data

## GENERATOR SPECIFICATIONS

Type	Synchronous
Rotor Insulation Class	H
Stator Insulation Class	H
Telephone Interference Factor (TIF)	<50
Alternator Output Leads 1-Phase	4 wire
Alternator Output Leads 3-Phase	6 wire (70, 80 & 150 kW) or 12 wire (100 & 130 kW)
Bearings	Sealed Ball
Coupling	Flexible Disc (70, 80 & 150 kW) or Gear Drive (100 & 130 kW)
Excitation System	Brushless

## VOLTAGE REGULATION

Type	Electronic
Sensing	Single Phase
Regulation	± 1%

## GOVERNOR SPECIFICATIONS

Type	Electronic
Frequency Regulation	Isochronous
Steady State Regulation	± 0.25%

## ELECTRICAL SYSTEM

Battery Charge Alternator	12 Volt 30 Amp
Static Battery Charger	2 Amp
Recommended Battery (battery not included)	Group 24F, 525 CCA (70, 80 & 150 kW) or Group 27F, 700 CCA (100 & 130 kW)
System Voltage	12 Volts

## GENERATOR FEATURES

Revolving field heavy duty generator  
Directly connected to the engine  
Operating temperature rise 120 °C above a 40 °C ambient  
Class H insulation is NEMA rated  
All models fully prototyped tested

## ENCLOSURE FEATURES

Aluminum weather protective enclosure	Ensures protection against mother nature. Electrostatically applied textured epoxy paint for added durability.
Enclosed critical grade muffler	Quiet, critical grade muffler is mounted inside the unit to prevent injuries.
Small, compact, attractive	Makes for an easy, eye appealing installation.
SAE	Sound attenuated enclosure ensures quiet operation.

## ENGINE SPECIFICATIONS: 80 kW

Make	Generac
Model	V-Type
Cylinders	8
Displacement (Liters)	5.4
Bore (in/mm)	3.55/90.2
Stroke (in/mm)	4.17/105.9
Compression Ratio	9:1
Intake Air System	Naturally Aspirated
Lifter Type	Hydraulic

## ENGINE SPECIFICATIONS: 70, 100, 130 &amp; 150 kW

Make	Generac
Model	V-Type
Cylinders	10
Displacement (Liters)	6.8
Bore (in/mm)	3.55/90.2
Stroke (in/mm)	4.17/105.9
Compression Ratio	9:1
Intake Air System	Naturally Aspirated
Lifter Type	Hydraulic

## ENGINE LUBRICATION SYSTEM

Oil Pump Type	Gear
Oil Filter Type	Full flow spin-on cartridge
Crankcase Capacity (qt/l)	5/4.7 (70, 100, 130 & 150 kW) or 6/5.7 (80 kW)

## ENGINE COOLING SYSTEM

Type	Closed
Water Pump	Belt driven
Fan Speed (rpm)	2300 - 70 kW 2174 - 80 kW 1670 - 100 kW 1950 - 130 kW 2200 - 150 kW
Fan Diameter (in/mm)	22/558.8 (70 kW) or 26/660.4 (80, 100, 130 & 150 kW)
Fan Mode	Pusher (70 kW) or Puller (80, 100, 130 & 150 kW)

## FUEL SYSTEM

Fuel Type	Natural gas, propane vapor
Carburetor	Down Draft
Secondary Fuel Regulator	Standard
Fuel Shut Off Solenoid	Standard
Operating Fuel Pressure	11-14" water column/21-26 mm HG

## 70 • 80 • 100 • 130 • 150 kW

## operating data

### GENERATOR OUTPUT VOLTAGE/kW - 60 Hz

		KW LPG	Amp LPG	kW Nat. Gas	Amp Nat. Gas	CB Size (Both)
QT070	120/240 V, 1Ø, 1.0 pf	67	292	64	267	300
	120/208 V, 3Ø, 0.8 pf	70	243	67	232	300
	120/240 V, 3Ø, 0.8 pf	70	211	67	201	250
	277/480 V, 3Ø, 0.8 pf	70	105	67	101	125
QT080	120/240 V, 1Ø, 1.0 pf	77	333	77	333	400
	120/208 V, 3Ø, 0.8 pf	80	278	80	278	300
	120/240 V, 3Ø, 0.8 pf	80	241	80	240	300
	277/480 V, 3Ø, 0.8 pf	80	120	80	120	150
QT100	120/240 V, 1Ø, 1.0 pf	100	417	89	371	450
	120/208 V, 3Ø, 0.8 pf	100	347	94	326	400
	120/240 V, 3Ø, 0.8 pf	100	301	94	283	350
	277/480 V, 3Ø, 0.8 pf	100	150	94	141	175
QT130	120/240 V, 1Ø, 1.0 pf	130	542	117	488	600
	120/208 V, 3Ø, 0.8 pf	130	451	122	423	500
	120/240 V, 3Ø, 0.8 pf	130	391	122	367	450
	277/480 V, 3Ø, 0.8 pf	130	195	122	183	225
QT150	120/240 V, 1Ø, 1.0 pf	144	625	136	567	700
	120/208 V, 3Ø, 0.8 pf	150	520	142	493	600
	120/240 V, 3Ø, 0.8 pf	150	451	142	427	500
	277/480 V, 3Ø, 0.8 pf	150	225	142	214	250

### SURGE CAPACITY IN AMPS

		Voltage Dip @ < .4 pf	
		15%	30%
QT070	120/240 V, 1Ø	129	356
	120/208 V, 3Ø	194	471
	120/240 V, 3Ø	168	408
	277/480 V, 3Ø	83	201
QT080	120/240 V, 1Ø	174	435
	120/208 V, 3Ø	186	466
	277/480 V, 3Ø	70	175
QT100	120/240 V, 1Ø	150	413
	120/208 V, 3Ø	186	452
	120/240 V, 3Ø	161	392
	277/480 V, 3Ø	107	261
QT130	120/240 V, 1Ø	236	648
	120/208 V, 3Ø	364	885
	120/240 V, 3Ø	315	767
	277/480 V, 3Ø	161	390
QT150	120/240 V, 1Ø	486	1214
	120/208 V, 3Ø	534	1334
	120/240 V, 3Ø	463	1156
	277/480 V, 3Ø	250	624

### ENGINE FUEL CONSUMPTION

		Natural Gas		Propane		
		(ft³/hr)	(m³/hr)	(gal/hr)	(l/hr)	(ft³/hr)
QT070	Exercise cycle	110	3.1	1.2	4.6	44
	25% of rated load	260	7.4	2.85	10.8	104
	50% of rated load	500	14.2	5.46	20.8	200
	75% of rated load	696	19.8	7.62	29.1	280
	100% of rated load	1020	29	11.17	42.6	411
QT080	Exercise cycle	95	2.7	1.4	5.51	53
	25% of rated load	549.5	15.6	3.46	13.11	126
	50% of rated load	784.4	22.2	6.62	25.1	241
	100% of rated load	1252.2	35.5	12.78	48.38	465
QT100	Exercise cycle	130	3.7	1.4	5.4	52
	25% of rated load	371	10.5	4.1	15.5	149
	50% of rated load	713	20.3	7.9	29.8	287
	100% of rated load	1260	35.8	13.9	52.6	507
QT130	Exercise cycle	135	3.8	1.4	5.7	55
	25% of rated load	482	13.7	5.3	20	193
	50% of rated load	927	26.3	10.3	38.7	373
	100% of rated load	1786	50.8	19.8	74.6	719
QT150	Exercise cycle	155	4.4	1.7	6.5	63
	25% of rated load	556	15.8	6.09	23.2	224
	50% of rated load	1070	30.4	11.72	44.7	431
	75% of rated load	1491	42.4	16.33	62.3	600
	100% of rated load	2061	58.6	22.57	86.1	830

Note: Fuel pipe must be sized for full load.

For BTU content, multiply ft³/hr x 2500 (LP) or ft³/hr x 1000 (NG).

For Megajoule content, multiply m³/hr x 93.15 (LP) or m³/hr x 37.26 (NG).

Refer to "Emissions Data Sheets" for maximum fuel flow for EPA and SCAQMD permitting purposes.

STANDBY RATING: Standby ratings apply to installations served by a reliable utility source. The standby rating is applicable to varying loads for the duration of a power outage. There is no overload capability for this rating. Ratings are in accordance with ISO-3046-1. Design and specifications are subject to change without notice.

## 70 • 80 • 100 • 130 • 150 kW

## operating data

## ENGINE COOLING

	70 kW	80 kW	100 kW	130 kW	150 kW
Air flow (inlet air including alternator and combustion air in ft <sup>3</sup> /min)	5200/147.2	5300/150.1	5500/155.7	6450/182.6	7800/220.9
System coolant capacity (gal/liters)	4.5/17	4/15.1	4.5/17	4.5/17	4.5/17
Heat rejection to coolant (BTU/hr)	287,000/302.8	316,000/333.4	342,000/360.8	496,000/523.3	568,000/599.3
Maximum operation air temperature on radiator (°C/°F)	60/150				
Maximum ambient temperature (°C/°F)	50/140				

## COMBUSTION REQUIREMENTS

Flow at rated power (cfm/cmm)	205/5.8	143/4	262/7.4	336/9.5	410/11.6
-------------------------------	---------	-------	---------	---------	----------

## SOUND EMISSIONS

Sound output in dB(A) at 23 ft (7 m) with generator in exercise mode*	64	65	68	69	66
Sound output in dB(A) at 23 ft (7 m) with generator operating at normal load*	72	74	72	75	79

\*Sound levels are taken from the front of the generator. Sound levels taken from other sides of the generator may be higher depending on installation parameters.

## EXHAUST

Exhaust flow at rated output (cfm/cmm)	557/15.8	720/20.4	888/25.1	1119/31.7	1535/43.5
Exhaust temperature at muffler outlet (°C/°F)	477/890	796/1465	516/960	521/970	593/1100

## ENGINE PARAMETERS

Rated Synchronous rpm	1800	3600	2300	2970	3600
-----------------------	------	------	------	------	------

## POWER ADJUSTMENT FOR AMBIENT CONDITIONS

Temperature Deration .....	3% for every 10 °C above 25 °C or 1.65% for every 10 °F above 77 °F
Altitude Deration (70,100,130 & 150) .....	1% for every 100 m above 183 m or 3% for every 1000 ft above 600 ft
Altitude Deration (80 kW) .....	1% for every 100 m above 915 m or 3% for every 1000 ft above 3000 ft

## CONTROLLER FEATURES

2-Line Plain Text LCD Display .....	Simple user interface for ease of operation.
Mode Switch: Auto .....	Automatic Start on Utility failure. 7 day exerciser
Off .....	Stops unit. Power is removed. Control and charger still operate.
Manual .....	Start with starter control, unit stays on. If utility fails, transfer to load takes place.
Programmable start delay between 10-30 seconds .....	Standard 10 sec
Engine Start Sequence .....	Cyclic cranking: 16 sec on, 7 rest (90 sec maximum duration)
Engine Warm-up .....	5 sec
Engine Cool-Down .....	1 min
Starter Lock-out .....	Starter cannot re-engage until 5 sec after engine has stopped.
Smart Battery Charger .....	Standard
Automatic Voltage Regulation with Over and Under Voltage Protection .....	Standard
Automatic Low Oil Pressure Shutdown .....	Standard
Overspeed Shutdown .....	Standard, 72 Hz
High Temperature Shutdown .....	Standard
Overcrank Protection .....	Standard
Safety Fused .....	Standard
Failure to Transfer Protection .....	Standard
Low Battery Protection .....	Standard
50 Event Run Log .....	Standard
Future Set Capable Exerciser .....	Standard
Incorrect Wiring Protection .....	Standard
Internal Fault Protection .....	Standard
Common External Fault Capability .....	Standard
Governor Failure Protection .....	Standard

Drawing #0H7452-D  
70 • 80 • 100 • 130 • 150 kW

A TYPICAL RESIDENTIAL/COMMERCIAL LIQUID-COOLED GENERATOR CONNECTION PANEL

FEEDER SUPPLY FROM PANEL (REQUIRES 4-WIRE FEEDER)

RTS TRANSFER SWITCH

NOTE: MATCH WIRE NUMBERS TO TERMINAL NUMBERS

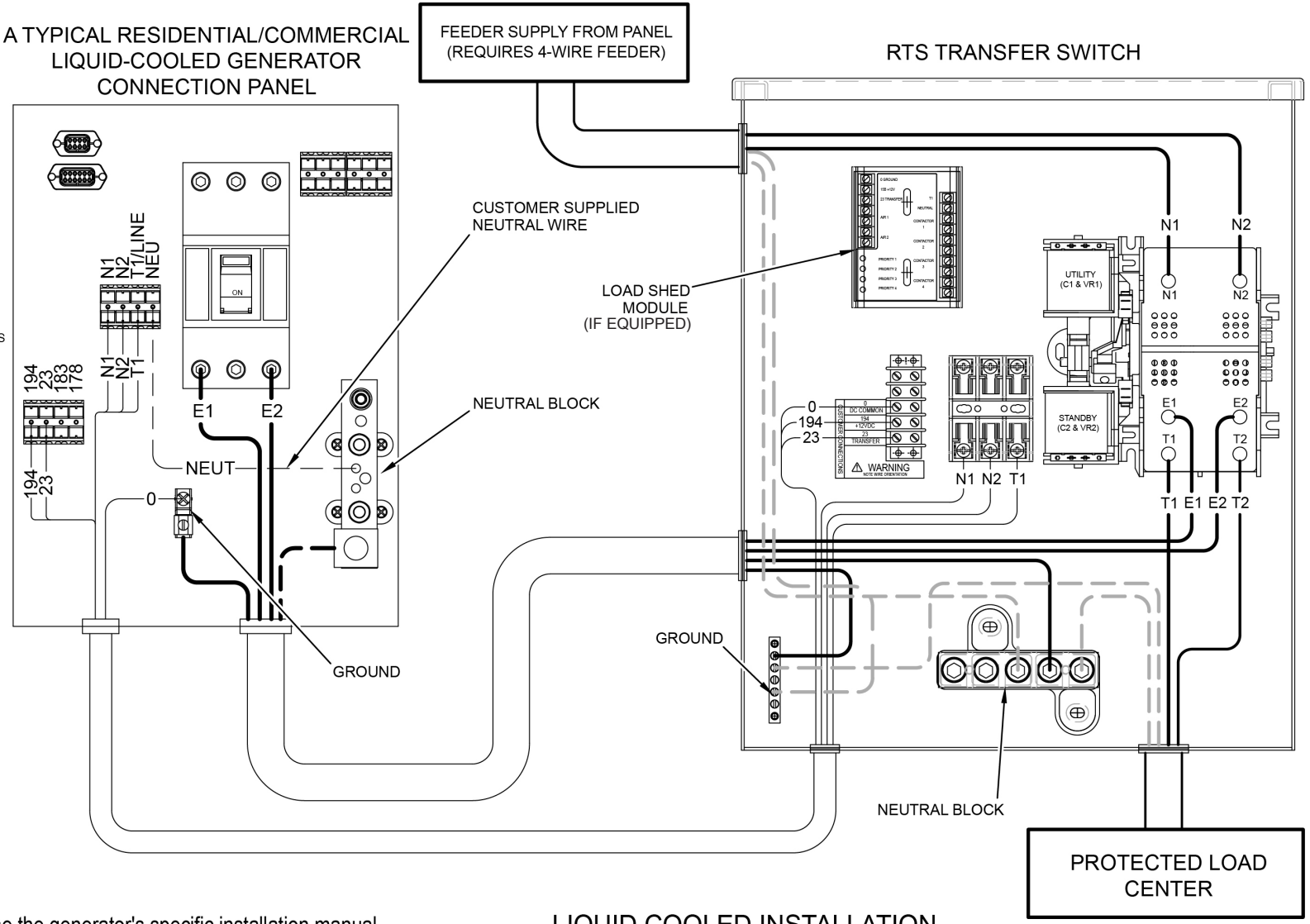

LIQUID COOLED INSTALLATION

Note: Use the generator's specific installation manual and wiring diagrams to verify generator wiring connections, as they may differ slightly from illustration.



WEIGHT DATA				
ENGINE/KW	ENCLOSURE MATERIAL	WEIGHT (GENSET ONLY) KG [LBS]	WEIGHT (WOODEN SHIPPING CRATE/SKID) KG [LBS]	SHIPPING WEIGHT (SKID AND GENSET) KG [LBS]
6.8L 100KW	ALUMINUM	1148 [2531]	79 [175]	1227 [2706]
6.8L 130KW	ALUMINUM	1224 [2702]	79 [175]	1303 [2877]
6.8L 150KW	ALUMINUM	1130 [2492]	79 [175]	1210 [2667]

- NOTES:
- 1) MINIMUM RECOMMENDED CONCRETE PAD SIZE: 1240(48.8") WIDE X 3230 (127.2") LONG. REFERENCE INSTALLATION GUIDE SUPPLIED WITH UNIT FOR CONCRETE PAD GUIDELINES.
  - 2) ALLOW SUFFICIENT ROOM ON ALL SIDES OF THE GENERATOR FOR MAINTENANCE AND SERVICING. THIS UNIT MUST BE INSTALLED IN ACCORDANCE WITH CURRENT APPLICABLE NFPA 37 AND NFPA 70 STANDARDS AS WELL AS ANY OTHER FEDERAL, STATE AND LOCAL CODES FOR MINIMUM DISTANCES FROM OTHER STRUCTURES.
  - 3) CIRCUIT BREAKER INFORMATION: SEE SPECIFICATION SHEET WITHIN OWNERS MANUAL.
  - 4) INSIDE STUB-UP AREA FOR AC LOAD LEAD CONDUIT CONNECTION, NEUTRAL CONNECTION, BATTERY CHARGER 120 VOLT AC (5 AMP MAX.) CONNECTION, AND ACCESS TO TRANSFER SWITCH CONTROL WIRES. REMOVE FRONT COVER FOR ACCESS.
  - 4A) FIELD CUT HOLE IS ONLY REQUIRED FOR MOUNTING OF GENERATOR ON AN EXISTING PAD.
  - 5) REFERENCE OWNERS MANUAL FOR LIFTING WARNINGS.
  - 6) REMOVE EITHER LEFT OR RIGHT HAND SIDE PANEL TO ACCESS EXHAUST MUFFLERS AND FAN BELT.

SERVICE ITEM ACCESSIBILITY CHART

SERVICE ITEM	ACCESS		
	100KW 6.8L	130KW 6.8L	150KW 6.8L
OIL FILL CAP	THRU RIGHT FRONT DOOR		
OIL DIP STICK	THRU LEFT FRONT DOOR		
OIL FILTER	THRU LEFT FRONT DOOR		
OIL DRAIN HOSE	THRU RIGHT FRONT DOOR		
RADIATOR DRAIN HOSE	THRU LEFT FRONT DOOR		
AIR CLEANER ELEMENT	EITHER FRONT DOORS		
SPARK PLUGS	BOTH FRONT DOORS		
MUFFLERS	SEE NOTE 6		
FAN BELT	SEE NOTE 6		
BATTERY	THRU RIGHT REAR DOOR		
*GEARBOX FILL & DRAIN	THRU RIGHT REAR DOOR		

\*NOTE: EXCLUDING 6.8L 150KW UNITS  
REFERENCE OWNERS MANUAL FOR PERIODIC REPLACEMENT PART LISTINGS

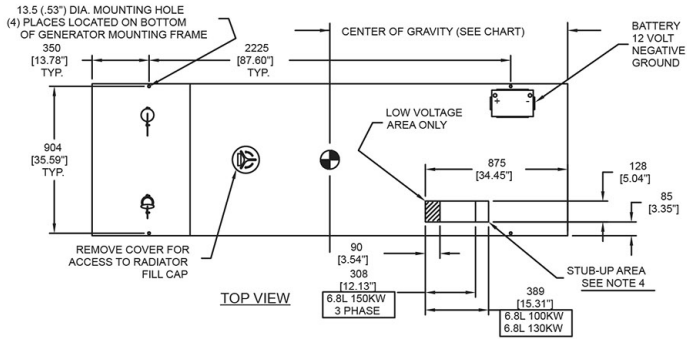
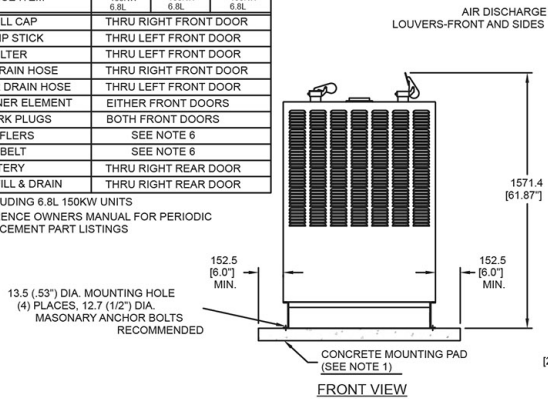

CENTER OF GRAVITY	
1275 (50.2")	- 100KW 6.8L
1230 (48.4")	- 130KW 6.8L
1315 (51.8")	- 150KW 6.8L

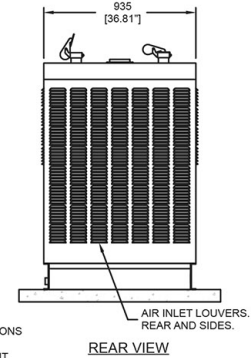
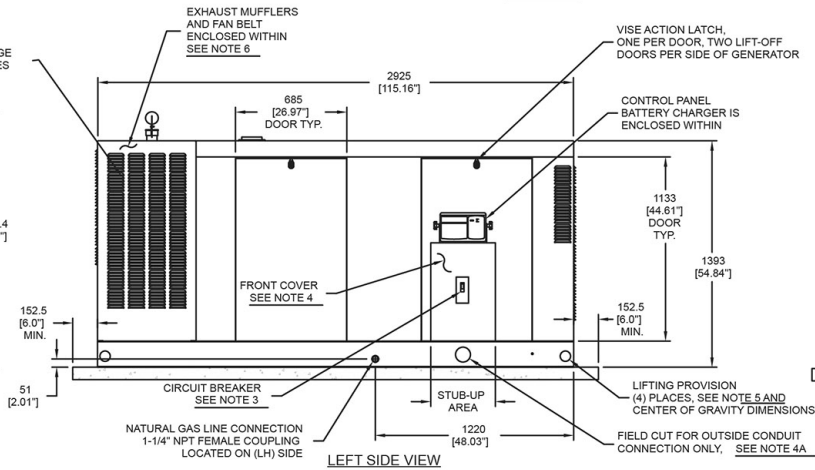
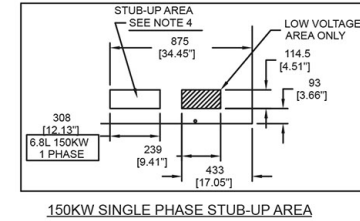

DIMENSIONS: MM [INCH]

100 • 130 • 150 KW

Installation layout

Drawing #0H4105-B



600-800 Amps

Non-Service Rated  
Automatic Transfer Switches

600 - 800 Amps, 1 and 3-phase



\*Built in the USA using domestic and foreign parts

## DESCRIPTION

Generac 600-800 amp non-service rated switches are compatible with the full 22-150kW line of liquid-cooled generators. The switches are open transition and are available in 120/240 1 $\phi$ , 120/208 3 $\phi$ , 120/240 3 $\phi$ , and 277/480 3 $\phi$ .

## STANDARD FEATURES

600-800 amp non-service rated transfer switches are housed in a rugged steel NEMA/UL Type 3R enclosure, with electrostatically applied and baked powder paint. The Heavy Duty Generac Contactor is a UL recognized device, designed for years of service. The controller at the generator handles all the timing, sensing, exercising functions, and transfer commands.

## 600-800 Amps

## Non-Service Rated Smart Transfer Switches

## Functions

All timing and sensing functions originate in the generator controller

Utility voltage drop-out.....	<60%
Timer to generator start.....	10 second factory set, adjustable between 2-1500 seconds by a qualified dealer*
Engine warm up delay.....	5 seconds
Standby voltage sensor.....	.60% for 5 seconds
Utility voltage pickup.....	>80%
Re-transfer time delay.....	15 seconds
Engine cool-down timer.....	60 seconds
Exerciser.....	12 minutes every 7 days

The transfer switch can be operated manually without power applied.

\*When used in conjunction with units utilizing Evolution™ controls

## Specifications

Model	RTSC600A3	RTSN600G3	RTSN600J3	RTSN600K3	RTSC800A3	RTSN800G3	RTSN800J3	RTSN800K3
Amps	600				800			
Voltage	120/240 1Ø	120/208 3Ø	120/240 3Ø	277/480 3Ø	120/240 1Ø	120/208 3Ø	120/240 3Ø	277/480 3Ø
Load Transition Type (Automatic)					Open Transition			
Enclosure Type					NEMA/UL 3R			
Withstand Rating (Amps)	42,000				65,000			
Lug Range	1/0 - 500 MCM				4/0 - 500 MCM			

## Features

- Electrically operated, mechanically-held contacts for fast, positive connections.
- Rated for all classes of load, 100% equipment rated, both inductive and resistive.
- 160 millisecond transfer time.
- Single coil design.
- Main contacts are silver plated or silver alloy to resist welding and sticking.
- NEMA/UL 3R (indoor/outdoor rated) rugged steel enclosure is standard.
- Limited 5 Year Warranty.

## Dimensions

Voltages*	Height (in./mm)		Width (in./mm)		Depth (in./mm)	Weight (lbs/kilos)
	H1	H2	W1	W2		
120/240 1Ø, 120/208 3Ø, 120/240 3Ø	61.4/1559.6	66/1676.4	30/762	36/914.4	21/533.4	337.5/153.09
277/480 3Ø	61.4/1559.6	66/1676.4	30/762	36/914.4	21/533.4	353.5/160.34

\*Includes 600 & 800 amp switches.

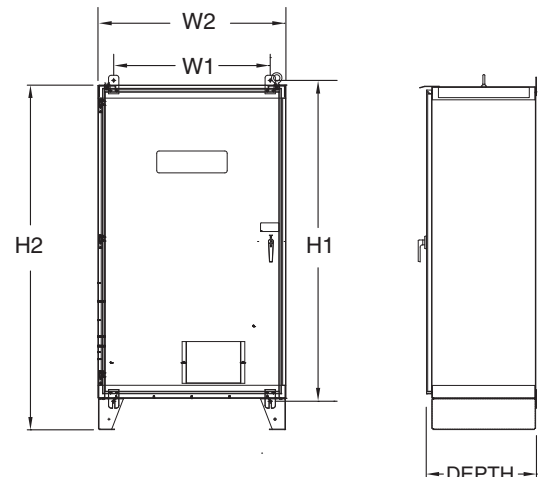

## **Venue #5 – Statham Hall, 138 N Jackson Street, Lone Pine, CA**

This scope of work includes all work necessary, whether reflected in this scope of work or not, to complete the installation of a Generac QT100 100 kW, Single Phase generator and Generac 400 Amp automatic transfer switch (ATS), both of which will be provided by Inyo County Public Works.

This scope of work involves the demolition of the existing wood shed, protecting in-place the phone punch down block, excavation for an 8" thick concrete generator pad, formwork, rebar, concrete materials, concrete placement and finishing, concrete blankets for subgrade and concrete frost protection, tapping into the tank manifold, trenching and backfill, underground propane line, epoxy coated steel risers on each end, including furnishing and installing properly-sized propane regulators, both high to medium and medium to low pressure, setting of the generator on the concrete pad including any crane costs, installation of below grade and surface mounted conduit for generator power, battery charger circuit, block heater circuit, and control wiring, interception of the existing subfeed from main breaker to distribution panel, and the installation of the automatic transfer switch. Contractor is responsible for the design of all work, and must submit a plan, single line drawing, and product data sheets with respect to conduit size and material, conduit routing, conductor and breaker sizing, grounding or bonding, etc. for approval by the Building Official and the County Engineer prior to commencing work.





























# LEGEND

1. Propane Tanks (E)
2. High to Medium Pressure Regulator (N)
3. Buried Propane Line (N)
4. Wood Shed - Demolish
5. Phone Block (E) - Protect in Place
6. Concrete Pad (N)
7. Generac QT100 Generator (N) - County  
Furnished, Contractor Installed
8. Medium to Low Propane Regulator (N)
9. Automatic Transfer Switch
10. Generator Power Circuit (N)
11. Control Wiring Circuit (N)
12. Block Heater & Battery Charger Circuit (N)
13. Tree (E) - To Remain
14. Main Switchgear (E) - To Remain
15. 4" Bollards (N) - 3 Each

Modular  
Building

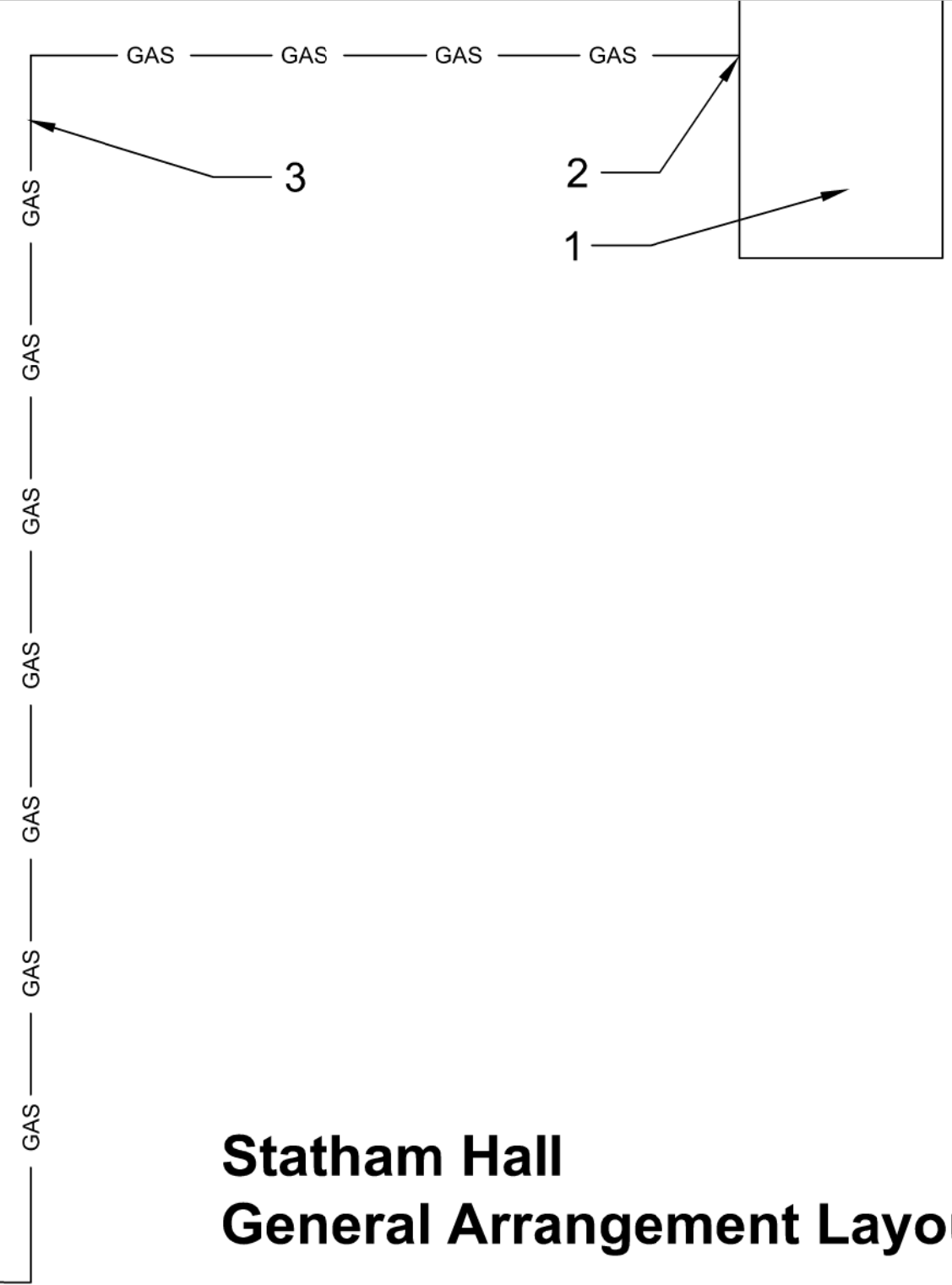
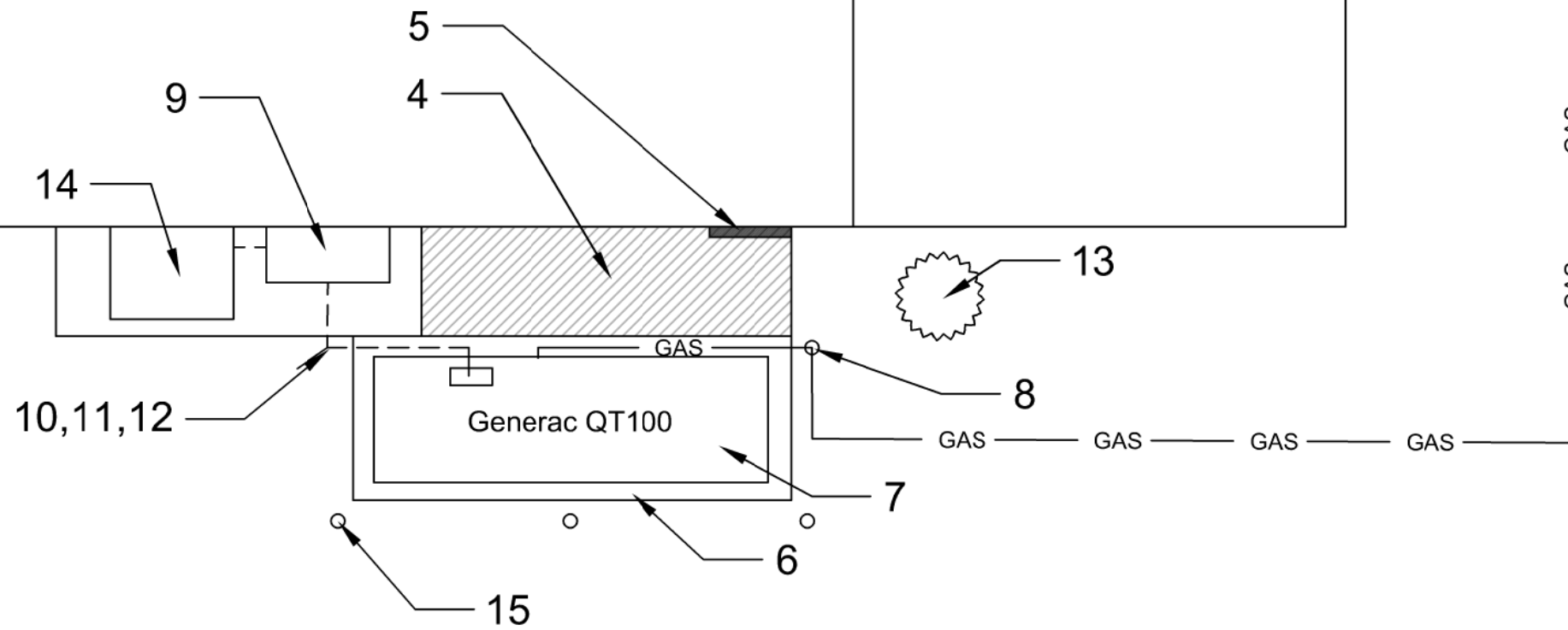

## Statham Hall General Arrangement Layout

Inyo County Public Works  
Design: GLW 10/20/2020  
Scale: 1/4" = 1' - 0", @ 11" x 17"

## Standby Generators

### Standby Generators Liquid-Cooled Gaseous Engine

#### Statham Hall

#### INCLUDES:

- Two Line LCD Tri-Lingual Digital Nexus™ Controller
- Isochronous Electronic Governor
- Sound Attenuated Enclosure
- Closed Coolant Recovery System
- Smart Battery Charger
- UV/Ozone Resistant Hoses
- ±1% Voltage Regulation
- Natural Gas or LP Operation
- 2 Year Limited Warranty
- UL 2200 Listed

#### Standby Power Rating

- Model QT070 (Aluminum - Bisque) - 70 kW 60 Hz
- Model QT080 (Aluminum - Bisque) - 80 kW 60 Hz
- Model QT100 (Aluminum - Bisque) - 100 kW 60 Hz
- Model QT130 (Aluminum - Bisque) - 130 kW 60 Hz
- Model QT150 (Aluminum - Bisque) - 150 kW 60 Hz



QUIET-TEST™

Meets EPA Emission Regulations

70, 100, 130 & 150 kW meet CA/MA emissions requirement with optional catalyst  
80 kW not for sale in CA/MA

## FEATURES

- **INNOVATIVE DESIGN & PROTOTYPE TESTING** are key components of GENERAC'S success in "IMPROVING POWER BY DESIGN." But it doesn't stop there. Total commitment to component testing, reliability testing, environmental testing, destruction and life testing, plus testing to applicable CSA, NEMA, EGSA, and other standards, allows you to choose GENERAC POWER SYSTEMS with the confidence that these systems will provide superior performance.
- **TEST CRITERIA:**
  - ✓ PROTOTYPE TESTED
  - ✓ SYSTEM TORSIONAL TESTED
  - ✓ NEMA MG1-22 EVALUATION
  - ✓ MOTOR STARTING ABILITY
- **SOLID-STATE, FREQUENCY COMPENSATED VOLTAGE REGULATION.** This state-of-the-art power maximizing regulation system is standard on all Generac models. It provides optimized FAST RESPONSE to changing load conditions and MAXIMUM MOTOR STARTING CAPABILITY by electronically torque-matching the surge loads to the engine. Digital voltage regulation at ±1%.
- **SINGLE SOURCE SERVICE RESPONSE** from Generac's extensive dealer network provides parts and service know-how for the entire unit, from the engine to the smallest electronic component.
- **GENERAC TRANSFER SWITCHES.** Long life and reliability are synonymous with GENERAC POWER SYSTEMS. One reason for this confidence is that the GENERAC product line includes its own transfer systems and controls for total system compatibility.

## 70 • 80 • 100 • 130 • 150 kW

## application &amp; engineering data

## GENERATOR SPECIFICATIONS

Type	Synchronous
Rotor Insulation Class	H
Stator Insulation Class	H
Telephone Interference Factor (TIF)	<50
Alternator Output Leads 1-Phase	4 wire
Alternator Output Leads 3-Phase	6 wire (70, 80 & 150 kW) or 12 wire (100 & 130 kW)
Bearings	Sealed Ball
Coupling	Flexible Disc (70, 80 & 150 kW) or Gear Drive (100 & 130 kW)
Excitation System	Brushless

## VOLTAGE REGULATION

Type	Electronic
Sensing	Single Phase
Regulation	± 1%

## GOVERNOR SPECIFICATIONS

Type	Electronic
Frequency Regulation	Isochronous
Steady State Regulation	± 0.25%

## ELECTRICAL SYSTEM

Battery Charge Alternator	12 Volt 30 Amp
Static Battery Charger	2 Amp
Recommended Battery (battery not included)	Group 24F, 525 CCA (70, 80 & 150 kW) or Group 27F, 700 CCA (100 & 130 kW)
System Voltage	12 Volts

## GENERATOR FEATURES

Revolving field heavy duty generator  
Directly connected to the engine  
Operating temperature rise 120 °C above a 40 °C ambient  
Class H insulation is NEMA rated  
All models fully prototyped tested

## ENCLOSURE FEATURES

Aluminum weather protective enclosure	Ensures protection against mother nature. Electrostatically applied textured epoxy paint for added durability.
Enclosed critical grade muffler	Quiet, critical grade muffler is mounted inside the unit to prevent injuries.
Small, compact, attractive	Makes for an easy, eye appealing installation.
SAE	Sound attenuated enclosure ensures quiet operation.

## ENGINE SPECIFICATIONS: 80 kW

Make	Generac
Model	V-Type
Cylinders	8
Displacement (Liters)	5.4
Bore (in/mm)	3.55/90.2
Stroke (in/mm)	4.17/105.9
Compression Ratio	9:1
Intake Air System	Naturally Aspirated
Lifter Type	Hydraulic

## ENGINE SPECIFICATIONS: 70, 100, 130 &amp; 150 kW

Make	Generac
Model	V-Type
Cylinders	10
Displacement (Liters)	6.8
Bore (in/mm)	3.55/90.2
Stroke (in/mm)	4.17/105.9
Compression Ratio	9:1
Intake Air System	Naturally Aspirated
Lifter Type	Hydraulic

## ENGINE LUBRICATION SYSTEM

Oil Pump Type	Gear
Oil Filter Type	Full flow spin-on cartridge
Crankcase Capacity (qt/l)	5/4.7 (70, 100, 130 & 150 kW) or 6/5.7 (80 kW)

## ENGINE COOLING SYSTEM

Type	Closed
Water Pump	Belt driven
Fan Speed (rpm)	2300 - 70 kW 2174 - 80 kW 1670 - 100 kW 1950 - 130 kW 2200 - 150 kW
Fan Diameter (in/mm)	22/558.8 (70 kW) or 26/660.4 (80, 100, 130 & 150 kW)
Fan Mode	Pusher (70 kW) or Puller (80, 100, 130 & 150 kW)

## FUEL SYSTEM

Fuel Type	Natural gas, propane vapor
Carburetor	Down Draft
Secondary Fuel Regulator	Standard
Fuel Shut Off Solenoid	Standard
Operating Fuel Pressure	11-14" water column/21-26 mm HG

## 70 • 80 • 100 • 130 • 150 kW

## operating data

### GENERATOR OUTPUT VOLTAGE/kW - 60 Hz

		kW LPG	Amp LPG	kW Nat. Gas	Amp Nat. Gas	CB Size (Both)
QT070	120/240 V, 1Ø, 1.0 pf	67	292	64	267	300
	120/208 V, 3Ø, 0.8 pf	70	243	67	232	300
	120/240 V, 3Ø, 0.8 pf	70	211	67	201	250
	277/480 V, 3Ø, 0.8 pf	70	105	67	101	125
QT080	120/240 V, 1Ø, 1.0 pf	77	333	77	333	400
	120/208 V, 3Ø, 0.8 pf	80	278	80	278	300
	120/240 V, 3Ø, 0.8 pf	80	241	80	240	300
	277/480 V, 3Ø, 0.8 pf	80	120	80	120	150
QT100	120/240 V, 1Ø, 1.0 pf	100	417	89	371	450
	120/208 V, 3Ø, 0.8 pf	100	347	94	326	400
	120/240 V, 3Ø, 0.8 pf	100	301	94	283	350
	277/480 V, 3Ø, 0.8 pf	100	150	94	141	175
QT130	120/240 V, 1Ø, 1.0 pf	130	542	117	488	600
	120/208 V, 3Ø, 0.8 pf	130	451	122	423	500
	120/240 V, 3Ø, 0.8 pf	130	391	122	367	450
	277/480 V, 3Ø, 0.8 pf	130	195	122	183	225
QT150	120/240 V, 1Ø, 1.0 pf	144	625	136	567	700
	120/208 V, 3Ø, 0.8 pf	150	520	142	493	600
	120/240 V, 3Ø, 0.8 pf	150	451	142	427	500
	277/480 V, 3Ø, 0.8 pf	150	225	142	214	250

3 of 9

### SURGE CAPACITY IN AMPS

		Voltage Dip @ < .4 pf	
		15%	30%
QT070	120/240 V, 1Ø	129	356
	120/208 V, 3Ø	194	471
	120/240 V, 3Ø	168	408
	277/480 V, 3Ø	83	201
QT080	120/240 V, 1Ø	174	435
	120/208 V, 3Ø	186	466
	277/480 V, 3Ø	70	175
QT100	120/240 V, 1Ø	150	413
	120/208 V, 3Ø	186	452
	277/480 V, 3Ø	107	261
QT130	120/240 V, 1Ø	236	648
	120/208 V, 3Ø	364	885
	120/240 V, 3Ø	315	767
	277/480 V, 3Ø	161	390
QT150	120/240 V, 1Ø	486	1214
	120/208 V, 3Ø	534	1334
	120/240 V, 3Ø	463	1156
	277/480 V, 3Ø	250	624

### ENGINE FUEL CONSUMPTION

		Natural Gas		Propane		
		(ft³/hr)	(m³/hr)	(gal/hr)	(l/hr)	(ft³/hr)
QT070	Exercise cycle	110	3.1	1.2	4.6	44
	25% of rated load	260	7.4	2.85	10.8	104
	50% of rated load	500	14.2	5.46	20.8	200
	75% of rated load	696	19.8	7.62	29.1	280
	100% of rated load	1020	29	11.17	42.6	411
QT080	Exercise cycle	95	2.7	1.4	5.51	53
	25% of rated load	549.5	15.6	3.46	13.11	126
	50% of rated load	784.4	22.2	6.62	25.1	241
	75% of rated load	1024.8	29.0	9.24	34.96	336
QT100	Exercise cycle	130	3.7	1.4	5.4	52
	25% of rated load	371	10.5	4.1	15.5	149
	50% of rated load	713	20.3	7.9	29.8	287
	75% of rated load	991	28.2	11	41.5	400
	100% of rated load	1260	35.8	13.9	52.6	507
QT130	Exercise cycle	135	3.8	1.4	5.7	55
	25% of rated load	482	13.7	5.3	20	193
	50% of rated load	927	26.3	10.3	38.7	373
	75% of rated load	1292	36.7	14.3	54	520
QT150	Exercise cycle	155	4.4	1.7	6.5	63
	25% of rated load	556	15.8	6.09	23.2	224
	50% of rated load	1070	30.4	11.72	44.7	431
	75% of rated load	1491	42.4	16.33	62.3	600
	100% of rated load	2061	58.6	22.57	86.1	830

Note: Fuel pipe must be sized for full load.

For BTU content, multiply ft³/hr x 2500 (LP) or ft³/hr x 1000 (NG).

For Megajoule content, multiply m³/hr x 93.15 (LP) or m³/hr x 37.26 (NG).

Refer to "Emissions Data Sheets" for maximum fuel flow for EPA and SCAQMD permitting purposes.

STANDBY RATING: Standby ratings apply to installations served by a reliable utility source. The standby rating is applicable to varying loads for the duration of a power outage. There is no overload capability for this rating. Ratings are in accordance with ISO-3046-1. Design and specifications are subject to change without notice.



70 • 80 • 100 • 130 • 150 kW

operating data

## ENGINE COOLING

	70 kW	80 kW	100 kW	130 kW	150 kW
Air flow (inlet air including alternator and combustion air in ft <sup>3</sup> /min)	5200/147.2	5300/150.1	5500/155.7	6450/182.6	7800/220.9
System coolant capacity (gal/liters)	4.5/17	4/15.1	4.5/17	4.5/17	4.5/17
Heat rejection to coolant (BTU/hr)	287,000/302.8	316,000/333.4	342,000/360.8	496,000/523.3	568,000/599.3
Maximum operation air temperature on radiator (°C/°F)	60/150				
Maximum ambient temperature (°C/°F)	50/140				

## COMBUSTION REQUIREMENTS

Flow at rated power (cfm/cmm)	205/5.8	143/4	262/7.4	336/9.5	410/11.6
-------------------------------	---------	-------	---------	---------	----------

## SOUND EMISSIONS

Sound output in dB(A) at 23 ft (7 m) with generator in exercise mode*	64	65	68	69	66
Sound output in dB(A) at 23 ft (7 m) with generator operating at normal load*	72	74	72	75	79

\*Sound levels are taken from the front of the generator. Sound levels taken from other sides of the generator may be higher depending on installation parameters.

## EXHAUST

Exhaust flow at rated output (cfm/cmm)	557/15.8	720/20.4	888/25.1	1119/31.7	1535/43.5
Exhaust temperature at muffler outlet (°C/°F)	477/890	796/1465	516/960	521/970	593/1100

## ENGINE PARAMETERS

Rated Synchronous rpm	1800	3600	2300	2970	3600
-----------------------	------	------	------	------	------

## POWER ADJUSTMENT FOR AMBIENT CONDITIONS

Temperature Deration .....	3% for every 10 °C above 25 °C or 1.65% for every 10 °F above 77 °F
Altitude Deration (70,100,130 & 150) .....	1% for every 100 m above 183 m or 3% for every 1000 ft above 600 ft
Altitude Deration (80 kW) .....	1% for every 100 m above 915 m or 3% for every 1000 ft above 3000 ft

## CONTROLLER FEATURES

2-Line Plain Text LCD Display .....	Simple user interface for ease of operation.
Mode Switch: Auto .....	Automatic Start on Utility failure. 7 day exerciser
Off .....	Stops unit. Power is removed. Control and charger still operate.
Manual .....	Start with starter control, unit stays on. If utility fails, transfer to load takes place.
Programmable start delay between 10-30 seconds .....	Standard 10 sec
Engine Start Sequence .....	Cyclic cranking: 16 sec on, 7 rest (90 sec maximum duration)
Engine Warm-up .....	5 sec
Engine Cool-Down .....	1 min
Starter Lock-out .....	Starter cannot re-engage until 5 sec after engine has stopped.
Smart Battery Charger .....	Standard
Automatic Voltage Regulation with Over and Under Voltage Protection .....	Standard
Automatic Low Oil Pressure Shutdown .....	Standard
Overspeed Shutdown .....	Standard, 72 Hz
High Temperature Shutdown .....	Standard
Overcrank Protection .....	Standard
Safety Fused .....	Standard
Failure to Transfer Protection .....	Standard
Low Battery Protection .....	Standard
50 Event Run Log .....	Standard
Future Set Capable Exerciser .....	Standard
Incorrect Wiring Protection .....	Standard
Internal Fault Protection .....	Standard
Common External Fault Capability .....	Standard
Governor Failure Protection .....	Standard

**70 • 80 • 100 • 130 • 150 kW**

**available accessories**

Model #	Product	Description
G006463-4	Mobile Link™	Generac's Mobile Link allows you to check the status of your generator from anywhere that you have access to an Internet connection from a PC or with any smart device. You will even be notified when a change in the generator's status occurs via e-mail or text message. Note: Harness Adapter Kit required. Available in the U.S. only.
G006478-0	Harness Adapter Kit	The Harness Adapter Kit is required to make liquid-cooled units compatible with Mobile Link™.
G005632-1 - 70, 80 & 150 kW G005633-0 - 100 & 130 kW	Cold Weather Kit	If the temperature regularly falls below 32 °F (0 °C), install a cold weather kit to maintain optimal battery temperature. Kit consists of battery warmer with thermostat built into the wrap.
G005620-0 - 70, 100 & 130 kW G006204-0 - 80 kW G005667-0 - 150 kW	Extreme Cold Weather Kit	Recommended where the temperature regularly falls below 32 °F (0 °C) for extended periods of time. For liquid cooled units only.
G005651-0	Base Plug Kit	Add base plugs to the base of the generator to keep out debris.
G005703-0	Paint Kit	If the generator enclosure is scratched or damaged, it is important to touch-up the paint to protect from future corrosion. The paint kit includes the necessary paint to properly maintain or touch-up a generator enclosure.
G005660-0 - 70, 100, 130, and 150 kW G006915-0 - 80 kW	Scheduled Maintenance Kit	The Liquid-Cooled Scheduled Maintenance Kits offer all the hardware necessary to perform complete maintenance on Generac liquid-cooled generators.
G006664-0	Local Wireless Monitor	Completely wireless and battery powered, Generac's wireless remote monitor provides you with instant status information without ever leaving the house.
G006665-0	Wireless Remote Extension Harness	Recommended for use with the Wireless Remote on units up to 60 kW, required for use on units 70 kW or greater.
G006873-0	Smart Management Module (50 Amps)	Smart Management Modules are used in conjunction with the Automatic Transfer Switch to increase its power management capabilities. It provides additional power management flexibility not found in any other power management system.
G007005-0	Wi-Fi LP Fuel Level Monitor	The Wi-Fi enabled LP fuel level monitor provides constant monitoring of the connected LP fuel tank. Monitoring the LP tank's fuel level is an important step in making sure your generator is ready to run during an unexpected power failure. Status alerts are available through a free application to notify when your LP tank is in need of a refill.
G006510-0	E-Stop	E-stop allows for immediate fuel shutoff and generator shutdown in the event of an emergency.

70 • 80 • 100 • 130 • 150 kW

Drawing #0H7452-D

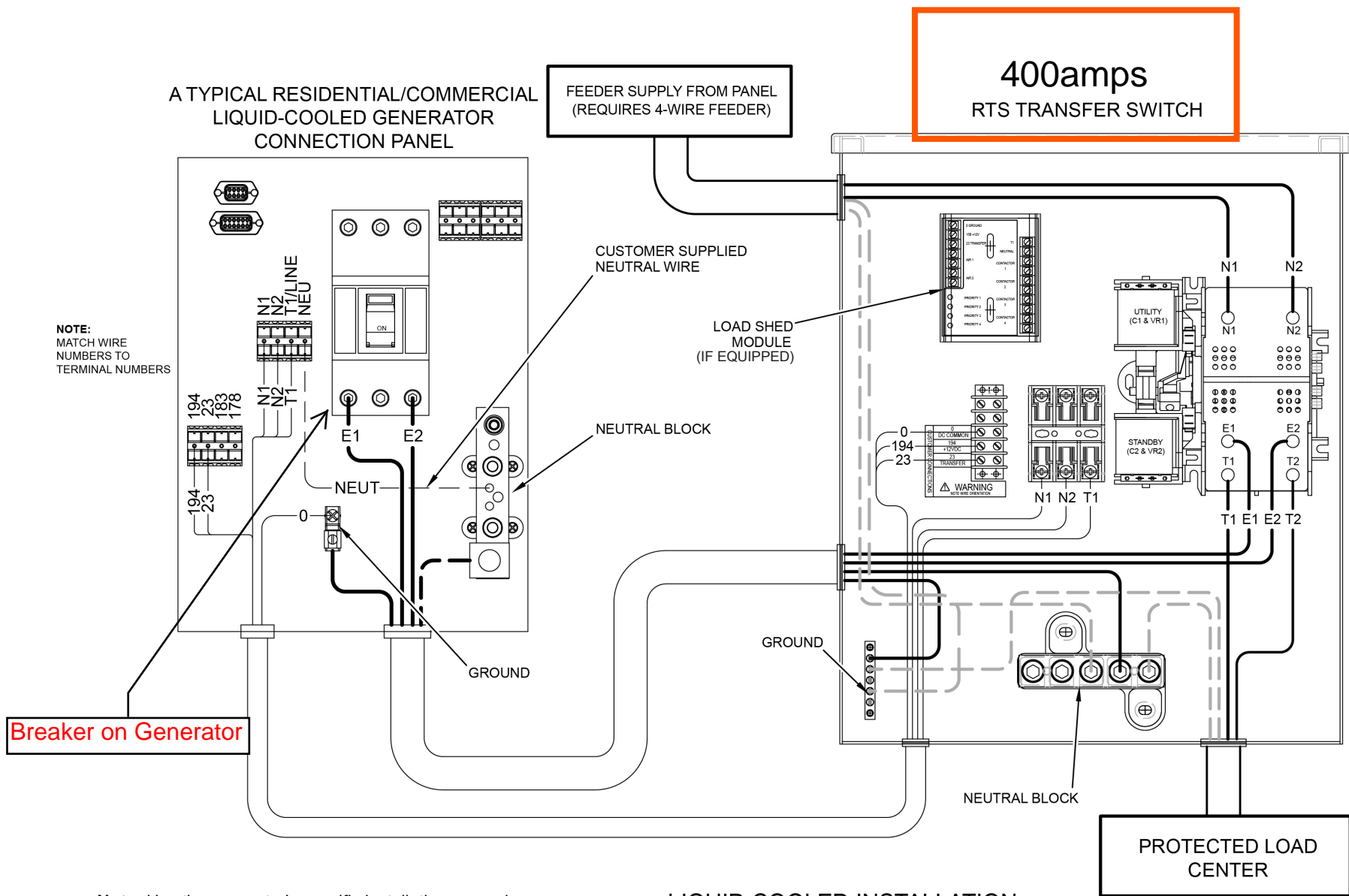

**NOTE:**  
MATCH WIRE  
NUMBERS TO  
TERMINAL NUMBERS

**Breaker on Generator**

**400amps  
RTS TRANSFER SWITCH**

LIQUID COOLED INSTALLATION

**Note:** Use the generator's specific installation manual and wiring diagrams to verify generator wiring connections, as they may differ slightly from illustration.

ENGINE KW	ENCLOSURE	WEIGHT DATA		
		WEIGHT (KGF)	WEIGHT (WOODEN SHIPPING) (KGS)	SHIPPING WEIGHT (KGS)
6.8L 100KW	ALUMINUM	1148 [2531]	79 [175]	1227 [2706]
6.8L 130KW	ALUMINUM	1224 [2699]	79 [175]	1304 [2874]
6.8L 150KW	ALUMINUM	1130 [2492]	79 [175]	1210 [2667]

**NOTES:**

- 1) MINIMUM RECOMMENDED CONCRETE PAD SIZE: 1240(48.8") WIDE X 3230 (127.2") LONG. REFERENCE INSTALLATION GUIDE SUPPLIED WITH UNIT FOR CONCRETE PAD GUIDELINES.
- 2) ALLOW SUFFICIENT ROOM ON ALL SIDES OF THE GENERATOR FOR MAINTENANCE AND SERVICING. THIS UNIT MUST BE INSTALLED IN ACCORDANCE WITH CURRENT APPLICABLE NFPA 37 AND NFPA 70 STANDARDS AS WELL AS ANY OTHER FEDERAL, STATE AND LOCAL CODES FOR MINIMUM DISTANCES FROM OTHER STRUCTURES.
- 3) CIRCUIT BREAKER INFORMATION: SEE SPECIFICATION SHEET WITHIN OWNERS MANUAL.
- 4) INSIDE STUB-UP AREA FOR AC LOAD LEAD CONDUIT CONNECTION, NEUTRAL CONNECTION, BATTERY CHARGER 120 VOLT AC (5 AMP MAX.) CONNECTION, AND ACCESS TO TRANSFER SWITCH CONTROL WIRES. REMOVE FRONT COVER FOR ACCESS.
- 4A) FIELD CUT HOLE IS ONLY REQUIRED FOR MOUNTING OF GENERATOR ON AN EXISTING PAD.
- 5) REFERENCE OWNERS MANUAL FOR LIFTING WARNINGS.
- 6) REMOVE EITHER LEFT OR RIGHT HAND SIDE PANEL TO ACCESS EXHAUST MUFFLERS AND FAN BELT.

**SERVICE ITEM ACCESSIBILITY CHART**

SERVICE ITEM	ACCESS		
	100KW 6.8L	130KW 6.8L	150KW 6.8L
OIL FILL CAP	THRU RIGHT FRONT DOOR		
OIL DIP STICK	THRU LEFT FRONT DOOR		
OIL FILTER	THRU LEFT FRONT DOOR		
OIL DRAIN HOSE	THRU RIGHT FRONT DOOR		
RADIATOR DRAIN HOSE	THRU LEFT FRONT DOOR		
AIR CLEANER ELEMENT	EITHER FRONT DOORS		
SPARK PLUGS	BOTH FRONT DOORS		
MUFFLERS	SEE NOTE 6		
FAN BELT	SEE NOTE 6		
BATTERY	THRU RIGHT REAR DOOR		
*GEARBOX FILL & DRAIN	THRU RIGHT REAR DOOR		

\*NOTE: EXCLUDING 6.8L 150KW UNITS  
REFERENCE OWNERS MANUAL FOR PERIODIC REPLACEMENT PART LISTINGS

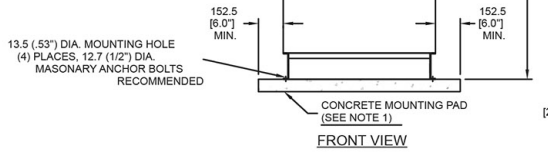

**FRONT VIEW**

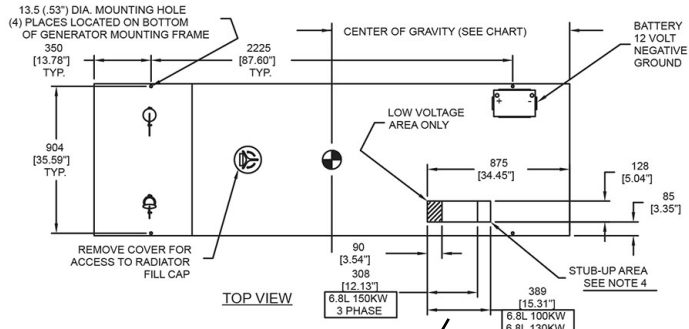

**TOP VIEW**

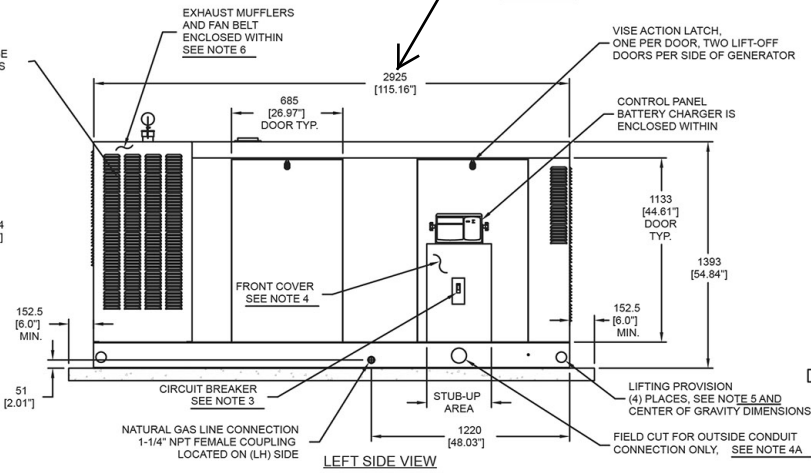

**LEFT SIDE VIEW**

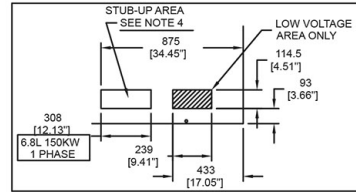

**150KW SINGLE PHASE STUB-UP AREA**

CENTER OF GRAVITY	
1275 (50.2")	100KW 6.8L
1230 (48.4")	130KW 6.8L
1315 (51.8")	150KW 6.8L

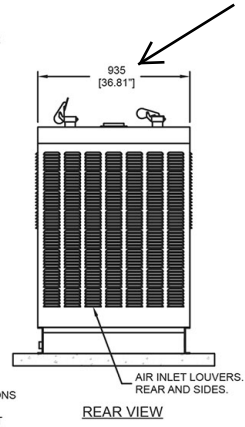

**REAR VIEW**

DIMENSIONS: MM [INCH]

Drawing #0H4105-B

installation layout

TRI-COUNTY, BIG PINE, STATHAM HALL  
400A, 120/240V, SINGLE PHASE

## Automatic Transfer Switches

## Service and non-Service rated Automatic Smart Transfer Switches

100 - 400 Amps, Single Phase

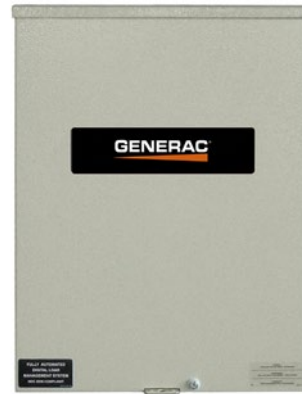
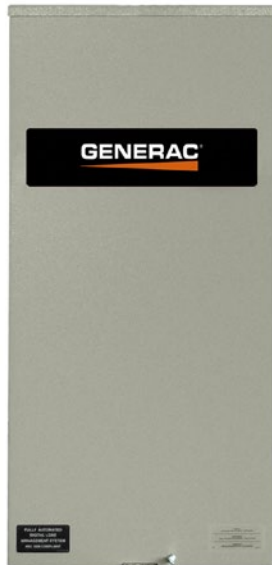

\*Built in the USA using domestic and foreign parts

\*CUL only applies to non-service rated switches

### Description

Generac Automatic Transfer Switches are designed for use with single phase generators that utilize an Evolution™ or Nexus™ Controller. The 100, 200, and 400 amp open transition switches are available in single phase in both service equipment rated and non-service equipment rated configurations. The 150 and 300 amp open transition switches are only available in a service rated equipment configuration.

### Standard Features

Service rated (RTSW) Generac Automatic Transfer Switches are housed in an aluminum NEMA/UL Type 3R enclosure\*, with electrostatically applied and baked powder paint. The Heavy Duty Generac Contactor is a UL recognized device, designed for years of service. The controller at the generator handles all the timing, sensing, exercising functions, and transfer commands. All switches are covered by a 5 year limited warranty.

\* Non-service rated (RTSC) switches are housed in a steel enclosure.

### DPM Technology

Through the use of digital power technology (DPM), these switches have the capability to manage up to 4 individual HVAC (24 VAC controlled) loads with no additional hardware. When used in tandem with Smart Management Modules, up to 8 more loads can be managed as well, providing the most installation efficient power management options available.

# 100-400 Amps, Single Phase

# Automatic Smart Transfer Switches

## Functions

All timing and sensing functions originate in the generator controller

Utility voltage drop-out.....	<60%
Timer to generator start.....	10 second factory set, adjustable between 2-1500 seconds by a qualified dealer*
Engine warm up delay.....	5 seconds
Standby voltage sensor.....	60% for 5 seconds
Utility voltage pickup.....	>80%
Re-transfer time delay.....	15 seconds
Engine cool-down timer.....	60 seconds
Exerciser.....	12 minutes every 7 days

The transfer switch can be operated manually without power applied.

\*When used in conjunction with units utilizing Evolution™ controls

## Specifications

Model	RTSC100A3	RTSW100A3	RTSW150A3	RTSC200A3	RTSW200A3	RTSW300A3	RTSC400A3	RTSW400A3
Amps	100	100	150	200	200	300	400	400
Voltage	120/240, 1Ø	120/240, 1Ø	120/240, 1Ø	120/240, 1Ø	120/240, 1Ø	120/240, 1Ø	120/240, 1Ø	120/240, 1Ø
Load Transition Type (Automatic)	Open Transition	Open Transition Service Rated	Open Transition Service Rated	Open Transition	Open Transition Service Rated	Open Transition Service Rated	Open Transition	Open Transition Service Rated
Enclosure Type	NEMA/UL 3R	NEMA/UL 3R	NEMA/UL 3R	NEMA/UL 3R	NEMA/UL 3R	NEMA/UL 3R	NEMA/UL 3R	NEMA/UL 3R
UL Rating	UL/CUL	UL	UL	UL/CUL	UL	UL	UL/CUL	UL
Withstand Rating (Amps)	10,000	10,000	22,000	10,000	22,000	22,000	22,000	22,000
Lug Range	1/0 - #14		250 MCM - #6			600 MCM - #4 or 1/0 - 250 MCM		

## Dimensions

Model		RTSC100A3	RTSW100A3	RTSW150A3	RTSC200A3	RTSW200A3	RTSW300A3	RTSC400A3	RTSW400A3
Height (in./mm)	H1	17.24/437.9	17.24/437.9	26.75/679.4	17.24/437.9	26.75/679.4	42.91/1089.9	31.25/793.8	42.91/1089.9
	H2	20/508	20/508	30/762	20/508	30/762	48/1219.2	36/914.4	48/1219.2
Width (in./mm)	W1	12.5/317.5	12.5/317.5	10.5/266.7	12.5/317.5	10.5/266.7	16.69/423.9	19.18/487.2	16.69/423.9
	W2	14.6/370.8	14.6/370.8	13.5/342.9	14.6/370.8	13.5/342.9	21.82/554.2	24/609.6	21.82/554.2
Depth (in./mm)		7.09/180.1	7.09/180.1	6.3/160.1	7.09/180.1	6.3/160.1	10.06/255.5	10.06/255.5	10.06/255.5
Weight (lbs./kilos)		20/9.07	22.5/10.21	39/17.69	20/9.07	39/17.69	140/63.5	133/60.33	140/63.5

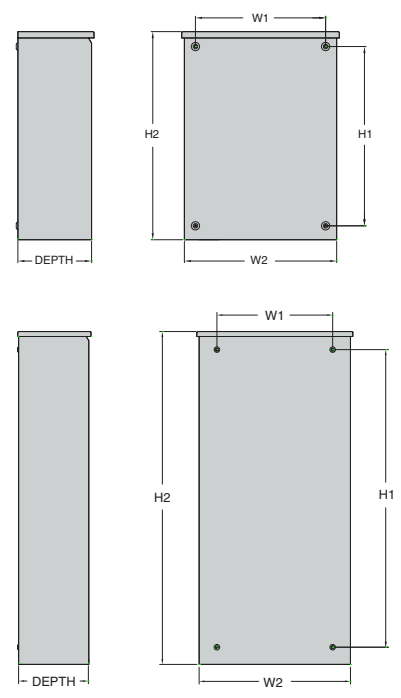



# County of Inyo



## Public Works

### CONSENT - ACTION REQUIRED

**MEETING:** November 3, 2020

**FROM:** Trevor Taylor

**SUBJECT:** Request authorization to purchase one new John Deere 672G Motor Grader

---

**RECOMMENDED ACTION:**

Request Board authorize a purchase order in an amount not to exceed \$337,414.72, payable to Coastline Equipment Company of Las Vegas, NV for one (1) new John Deere 672G Motor Grader with 6WD.

**SUMMARY/JUSTIFICATION:**

The Road Department is continuing its effort to bring its equipment fleet into compliance with EPA and California Air Resources Board (CARB) laws and requirements. Non-compliant equipment currently in the fleet will continue to become more obsolete as the operable hours and mileage become limited by law. The need for a new motor grader was identified as part of the continued effort to replace outdated and aging equipment in the Road Department fleet. The John Deere 672G Motor Grader will replace a 1977 CAT 12G Motor Grader that is currently damaged and not worth the cost of repair. The 1977 CAT Motor Grader will be salvaged for parts and removed from the Road Department fleet. The new John Deere 672G Motor Grader will meet all CARB Tier 4 emission laws and requirements.

The Road Department is utilizing Sourcewell, a cooperative purchasing program that provides nationally leveraged discount pricing through John Deere (Sourcewell Contract #032119-JDC). Coastline Equipment Company has been authorized by John Deere to sell directly off of this contract. The pricing offered by Sourcewell and Coastline Equipment provides the County with a discount of approximately 44% off of the list price for the John Deere Motor Grader, which makes the pricing highly competitive to comparable products offered in the market. Pursuant to Inyo County Purchasing Manual Section III(B)(5), the Road Department may purchase this equipment via Sourcewell / Coastline Equipment without soliciting bids.

The Road Department is recommending your Board authorize the purchase of one (1) new John Deere 672G Motor Grader from Coastline Equipment Company, to be delivered to the Road shop in Independence. The total expense, including delivery and taxes, is not to exceed \$337,414.72.

**BACKGROUND/HISTORY OF BOARD ACTIONS:**

**ALTERNATIVES AND CONSEQUENCES OF NEGATIVE ACTION:**

The Board could choose not to approve this purchase. This is not recommended, as the 1977 CAT Motor Grader needs to be replaced and the aging Road Department fleet has approximately 2/3 of its equipment under a usage



restriction due to CARB regulations. This usage restriction is having an adverse impact on Road operations and a new Tier IV compliant grader will aid in bringing the fleet closer to CARB compliance.

**OTHER AGENCY INVOLVEMENT:**

County Counsel  
Auditor's Office

**FINANCING:**

The funding for the Motor Grader has been approved in the FY 20/21 Road Department Budget, 034600, Object Code 5650, Equipment.

**ATTACHMENTS:**

1. Coastline Equipment Quote

**APPROVALS:**

Trevor Taylor	Created/Initiated - 10/16/2020
Darcy Ellis	Approved - 10/16/2020
Trevor Taylor	Approved - 10/22/2020
Breanne Nelums	Approved - 10/22/2020
Chris Cash	Approved - 10/22/2020
Marshall Rudolph	Approved - 10/23/2020
Amy Shepherd	Approved - 10/23/2020
Michael Errante	Final Approval - 10/23/2020

Quote Id: 22949213

---

13 October 2020

INYO COUNTY ROAD DEPARTMENT  
750 S CLAY ST  
INDEPENDENCE, CA 93526

We would like to take this opportunity to thank you for your recent interest in John Deere machinery.

Hi Trevor, Here is a budget quote utilizing Sourcewell Contract 032119-JDC. It shows to be good through the end of October, but we are not anticipating any changes in the program. I will check this on Nov 1 just to be safe. The machine is equipped pretty much identical to what you purchased in 2015. There are some new options, and I will send a brochure so you have all the current specifications. This quote does not include the Henke Hi Gate. If you would like me to put it in the quote, please let me know and we can do that. Please let us know if we can answer any questions. Thank you-Joe

Sincerely,  
Joe Gilmer  
JOE GILMER  
702-399-2700  
Coastline Equipment Company

**Quote Summary**

**Prepared For:**  
 INYO COUNTY ROAD DEPARTMENT  
 750 S CLAY ST  
 INDEPENDENCE, CA 93526  
 Business: 760-878-0281

**Prepared By:**  
 JOE GILMER  
 Coastline Equipment Company  
 3540 N 5th Street  
 N Las Vegas, NV 89032  
 Phone: 702-399-2700  
 Mobile: 702-493-9746  
 joe.gilmer@coastlineequipment.com

**Quote Id:** 22949213  
**Created On:** 13 October 2020

**Expiration Date:** 30 November 2020

<b>Equipment Summary</b>	<b>Suggested List</b>	<b>Selling Price</b>	<b>Qty</b>	<b>Extended</b>
JOHN DEERE 672G MOTOR GRADER with 6WD	\$ 510,022.00	\$ 298,268.91 X	1 =	\$ 298,268.91
John Deere Extended Warranty-84 Month 5,000 Hour Comprehensive Machine Warranty		\$ 14,877.00 X	1 =	\$ 14,877.00
<b>Sub Total</b>				<b>\$ 313,145.91</b>
<b>Equipment Total</b>				<b>\$ 313,145.91</b>

**Quote Summary**

Equipment Total	\$ 313,145.91
SubTotal	\$ 313,145.91
Sales Tax - (7.75%)	\$ 24,268.81
Total	\$ 337,414.72
<b>Balance Due</b>	<b>\$ 337,414.72</b>

Salesperson : X \_\_\_\_\_

Accepted By : X \_\_\_\_\_

# Selling Equipment

**Quote Id:** 22949213

**Customer:** INYO COUNTY ROAD DEPARTMENT

## JOHN DEERE 672G MOTOR GRADER with 6WD

**Hours:**
**Suggested List**
**Stock Number:**
**\$ 510,022.00**

Code	Description	Qty
8450T	672G MOTOR GRADER with 6WD	1
<b>Standard Options - Per Unit</b>		
170C	JDLINK Ultimate - 5 Year Subscription	1
1020	Armrest Fingertip Controls	1
1140	John Deere PowerTech PSS 9.0L meets EPA FT4 Emissions	1
1240	Dual 100 Amp Alternators (200 Amp total)	1
1310	Quick Service Group	1
1420	Severe Duty Fuel & Water Filtration System	1
1610	Hydraulic Pump Disconnect	1
1830	Engine Exhaust W/ Flat Black Stack (FT4 or Stage V only)	1
1910	Blade Impact Absorption System	1
2080	14 Ft. x 27 In. x 1 In. (4.27M x 686mm x 25mm) w/ 8 In. x 3/4 In. (203 x 19mm) Cutting Edge & 3/4 in. (19mm) Hardware	1
2575	No Grade Control Base Kit Installed	1
2605	English Manual W/ English Labels & Decals	1
2775	No Topcon 3D GPS Grade Control System installed	1
2840	Heavy Duty Dual Input Gearbox with Slip Clutch	1
4416	Michelin XGLA2	1
5070	Grade Pro Low Cab w/ Fixed Lower Front and Side Opening Windows, Laminated Glass	1
5510	Autoshift Transmission	1
5710	Transmission Solenoid Valve Guard	1
5830	Hydrau XR	1
6010	Powered Cab Air Precleaner	1
6140	Grade Pro Premium Heated, Leather/ Fabric, High-Wide Back Air Suspension Seat	1

# Selling Equipment

**Quote Id:** 22949213

**Customer:** INYO COUNTY ROAD DEPARTMENT

6585	Grade Pro Controls w/1 Front Auxiliary Function AND 1 Rear Auxiliary Function	1
6650	Grade Pro Controls - Left Side	1
6710	Front Push Block	1
6810	Rear Mounted Ripper/Scarifier Combination with Rear Hitch and Pin	1
7160	Deluxe Grading Lights (18 Halogen Lights)	1
7820	No Front Fenders	1
8120	24-to-12 Volt Converter (30 amps peak / 25 amps continuous)	1
8220	Heated Exterior Mounted Rearview Mirrors	1
8310	Lower Front Intermittent Wiper & Washer	1
8415	Premium AM/FM Radio with Bluetooth, Aux and Weather Band (WB).	1
8510	Air Conditioner Refrigerant Charged	1
8730	No Sound Absorption Package	1
8830	Rear Camera (R4)	1
9130	Rear Retractable Sun Shade	1
9210	Decelerator	1
9220	5.0 lbs. multi purpose (ABC) Dry Chemical Fire Extinguisher	1
9273	Right Side Engine Compartment Work Light	1
9280	Slow Moving Vehicle (SMV) Sign	1
9299	Beacon with Flip Down Cab Beacon Bracket (LH)	1
9360	Engine Block Heater	1
9370	Ether Starting Aid	1
9380	Heavy Duty Air Cleaner - 9.0L 14 in	1
9395	Adjusting Rotary Ejector Precleaner	1
9430	(9) Extra Scarifier Shanks w/Teeth For Rear Ripper/Scarifier	1
9450	Reversible Overlay End Bits	1
<b>Service Agreements</b>		
John Deere Extended Warranty - 84 Month 5,000 Hour Comprehensive Machine Warranty		



### Extended Warranty Proposal

**JOHN DEERE 672G MOTOR GRADER with 6WD**

Date : October 22, 2020

Machine/Use Information		Plan Description	Price	
Manufacturer	JOHN DEERE	Application	Deductible	
Equipment Type	672GXT	Coverage	List	\$ 14,877.00
Model	672GXT	Total Months		
Country	US	Total Hours		

Extended Warranty is available only through authorized John Deere Dealers for John Deere Products, and may be purchased at any time before the product's Standard Warranty, or Extended Warranty expires.

**Extended Warranty Proposal Prepared for:**

I have been offered this extended warranty and

Customer Name - Please Print

I ACCEPT the Extended Warranty

I DECLINE the Extended Warranty

Customer Signature

If declined, I fully understand that any equipment listed above is not covered for customer expenses due to component failures beyond the original basic warranty period provided by John Deere.

**Note :** This is **not** a contract. For specific Extended Warranty coverage terms and conditions, please refer to the actual Extended Warranty contract for more information and the terms, conditions and limitations of the agreement.

**What Extended Warranty is :**

The Extended Warranty Program is for the reimbursement on parts and labor for covered components that fail due to faulty material or original workmanship that occur beyond the John Deere Basic Warranty coverage period. The agreement is between Deere & Company and the owners of select John Deere Construction and Forestry equipment, who purchase the Extended Warranty Plans for the desired coverage as indicated in this proposal.

**What Extended Warranty is not :**

Extended Warranty is not insurance. It also does not cover routine maintenance or high wear items, or insurance-related risks/perils such as collision, overturn, vandalism, wind, fire, hail, etc. It does not cover loss of income during or after an equipment failure. See the actual product-specific Extended Warranty agreement for a complete listing of covered components, and limitations and conditions under the program.

**Features/Benefits:**

- Extended Warranty includes the following features and benefits under the program :
- Pays for parts and labor costs incurred on failed covered components (less any applicable deductibles),
- Does not require pre-approval before repairs are made by the authorized John Deere dealership,
- Payments are reimbursed directly to the dealership with no prepayment required by the contract holder.



# County of Inyo



## Sheriff - Veterans Service Office

### CONSENT - ACTION REQUIRED

**MEETING:** November 3, 2020

**FROM:** Office of the Sheriff

**SUBJECT:** Inyo-Mono County Veteran Services Annual Subvention Compliance forms

---

**RECOMMENDED ACTION:**

Request Board authorize the Chairperson to sign the Medi-Cal Certificate of Compliance Fiscal Year 2020-2021 and Certificate of Compliance for Subvention Fiscal Year 2020-2021.

**SUMMARY/JUSTIFICATION:**

Forms are required to participate and receive subvention funding from the State of California.

**BACKGROUND/HISTORY OF BOARD ACTIONS:**

N/A

**ALTERNATIVES AND CONSEQUENCES OF NEGATIVE ACTION:**

Funding will be withheld if not signed and submitted to the State.

**OTHER AGENCY INVOLVEMENT:**

N/A

**FINANCING:**

The subvention funds received by the County of Inyo off-set general fund cost for the Veterans Services and are estimated to be \$39,000 for Fiscal Year 2020-2021.

**ATTACHMENTS:**

1. Certificate of Compliance Subvention 2020-2021
2. Medi-Cal Certificate of Compliance Med 2020-2021

**APPROVALS:**

Riannah Reade

Darcy Ellis

Marshall Rudolph

Amy Shepherd

Jeffrey Hollowell

Created/Initiated - 10/27/2020

Approved - 10/27/2020

Approved - 10/27/2020

Approved - 10/29/2020

Final Approval - 10/29/2020



**CALIFORNIA DEPARTMENT OF VETERANS AFFAIRS**  
**Annual Subvention Certificate of Compliance**  
**FISCAL YEAR 2020/2021**

Charge:

Funds are distributed under this program to counties as partial reimbursement for expenses incurred in the operation of the County Veterans Service Office. Funds are distributed according to Military and Veterans Code Sections 972, and 972.1, a State General Fund Expenditure, and 972.2 a Special Fund Expenditure.

County Certification:

I certify that \_\_\_\_\_ County has appointed a veteran to serve as the County Veterans Service Officer according to California Code of Regulations Title 12, Subchapter 4. This County Veterans Service Officer will administer the aid provided for in Military and Veterans Code Division 4, Chapter 5. This County Veterans Service Officer must achieve and maintain accreditation from the California Department of Veterans Affairs within 18 months of employment or within 18 months of the County Veterans Service Officer position becoming vacant, whichever occurs first. Veterans Service Representative staff filing claims must also achieve and maintain accreditation from the California Department of Veterans Affairs within 18 months of employment.

I further certify that the County Veteran Service Officer will assist every veteran of the United States, as well as their dependents and survivors, in presenting and pursuing such claim as they may have against the United States. The County Veterans Service Officer and all accredited staff will also assist in establishing veterans, dependents and survivors' rights to any privilege, preference, care or compensation provided for by the laws and regulations of the United States, the State of California, or any local jurisdiction.

I certify that the current fiscal year proposed expenditures exceeds the actual fiscal year 1988-89 expenditures by at least, the full amount of the current annual allocation. I also agree that this county, through the County Veterans Service Office, will maintain records for audit. These records will be maintained for a minimum of two years. The county agrees to submit reports in accordance with the procedures and timelines established by CalVet and in accordance with the *CalVet Procedure Manual for Subvention and Medi-Cal Cost Avoidance* for the current state fiscal year. The County Veterans Service Officer will permit CalVet representatives to inspect all records.

I further authorize the County Veterans Service Officer to actively participate in the promotion of the California Veterans License Plate program.

\_\_\_\_\_  
Chair, County Board of Supervisors  
(or other County Official authorized  
by the Board to act on their behalf)

\_\_\_\_\_  
Date

**SCAN AND UPLOAD THIS COMPLETED FORM VIA THE AGENCY  
ATTACHMENTS IN VETPRO**

# CALIFORNIA DEPARTMENT OF VETERANS AFFAIRS

## Annual Medi-Cal Cost Avoidance Program Certificate of Compliance

Fiscal Year 2020/2021

\_\_\_\_\_ COUNTY

I certify that \_\_\_\_\_ County has appointed a County Veterans Service

Officer (CVSO) in compliance with California Code of Regulations, Title 12, Subchapter 4. Please consider this as our application to participate in the Medi-Cal Cost Avoidance Program authorized by Military and Veterans Code Section 972.5.

I understand and will comply with the following:

1. All activities of the CVSO for which payment is made by the CalVet under this agreement will reasonably benefit the Department of Health Care Services (DHCS) or realize cost avoidance to the Medi-Cal program. All State and County Medi-Cal Eligibility Workers who generate a Form MC 05 (Military Verification and Referral form) will be instructed to indicate the applicant's Aid Code on the face of the form.
2. All monies received under this agreement shall be allocated to and spent on the salaries and expenses of the CVSO.
3. This agreement is binding only if federal funds are available to CalVet from the DHCS.
4. The CVSO is responsible for administering this program in accordance with California Code of Regulations, Title 12, Subchapter 4 and *the CalVet Procedure Manual for Subvention and Medi-Cal Cost Avoidance* for the current state fiscal year.

\_\_\_\_\_  
Chair, County Board of Supervisors  
(or other County Official authorized  
by the Board to act on their behalf)

\_\_\_\_\_  
Date

**SCAN AND UPLOAD THIS COMPLETED FORM VIA THE  
AGENCY ATTACHMENTS IN VETPRO**



# County of Inyo



## Health & Human Services - Social Services

### DEPARTMENTAL - ACTION REQUIRED

**MEETING:** November 3, 2020

**FROM:** Tyler Davis

**SUBJECT:** Approve Contract with Philips Lifeline

---

**RECOMMENDED ACTION:**

Request Board ratify and approve the agreement between the County of Inyo and Philips Lifeline of Framingham, MA for the provision of an Emergency Response Monitoring System in an amount not to exceed \$6,000 for the period of July 1, 2020 through June 30, 2021, and authorize the Chairperson to sign, contingent upon all appropriate signatures being obtained.

**SUMMARY/JUSTIFICATION:**

Philips Lifeline provides Emergency Response Monitoring System services to thirty (30) seniors at a reduced rate through this contract. This service provides a valuable safety net to our elderly population, who are often at risk of injury or illness that require emergency response. This valuable service allows seniors to remain home with a sense of safety, knowing that they have ready access to help should they fall or become ill.

**BACKGROUND/HISTORY OF BOARD ACTIONS:**

NA

**ALTERNATIVES AND CONSEQUENCES OF NEGATIVE ACTION:**

The CAO could choose not to approve the Contract, which would result in the seniors potentially having their current services disrupted and unavailable for those who are unable to afford it.

**OTHER AGENCY INVOLVEMENT:**

None

**FINANCING:**

100% County General Funds. This contract is budgeted in the IC-GOLD Budget (056100) in Professional Services (5265)

**ATTACHMENTS:**

1. Phillips Lifeline Contract

**APPROVALS:**

Tyler Davis

Created/Initiated - 10/22/2020

Darcy Ellis	Approved - 10/22/2020
Keri Oney	Approved - 10/27/2020
Melissa Best-Baker	Approved - 10/27/2020
Marilyn Mann	Approved - 10/28/2020
Marshall Rudolph	Approved - 10/28/2020
Amy Shepherd	Approved - 10/29/2020
Marilyn Mann	Final Approval - 10/29/2020

**AGREEMENT BETWEEN COUNTY OF INYO  
AND LIFELINE SYSTEM COMPANY  
FOR THE PROVISION OF EMERGENCY RESPONSE MONITORING SERVICES**

**INTRODUCTION**

WHEREAS, the County of Inyo (hereinafter referred to as "County") may have the need for the Emergency Response Monitoring services of LIFELINE SYSTEMS COMPANY of Framingham, MA (hereinafter referred to as "Contractor"), and in consideration of the mutual promises, covenants, terms, and conditions hereinafter contained, the parties hereby agree as follows:

**TERMS AND CONDITIONS**

**1. SCOPE OF WORK.**

The Contractor shall furnish to the County, upon its request, those services and work set forth in Attachment A, attached hereto and by reference incorporated herein. Requests by the County to the Contractor to perform under this Agreement will be made by Keri Oney, whose title is: HHS Deputy Director, Aging & Social Services. Requests to the Contractor for work or services to be performed under this Agreement will be based upon the County's need for such services. The County makes no guarantee or warranty, of any nature, that any minimum level or amount of services or work will be requested of the Contractor by the County under this Agreement. County by this Agreement incurs no obligation or requirement to request from Contractor the performance of any services or work at all, even if County should have some need for such services or work during the term of this Agreement.

Services and work provided by the Contractor at the County's request under this Agreement will be performed in a manner consistent with the requirements and standards established by applicable federal, state, and County laws, ordinances, regulations, and resolutions. Such laws, ordinances, regulations, and resolutions include, but are not limited to, those which are referred to in this Agreement.

**2. TERM.**

The term of this Agreement shall be from July 1, 2020 to June 30, 2021 unless sooner terminated as provided below.

**3. CONSIDERATION.**

A. Compensation. County shall pay to Contractor in accordance with the Schedule of Fees (set forth as Attachment B) for the services and work described in Attachment A which are performed by Contractor at the County's request.

B. Travel and per diem. Contractor will not be paid or reimbursed for travel expenses or per diem which Contractor incurs in providing services and work requested by County under this Agreement.

C. No additional consideration. Except as expressly provided in this Agreement, Contractor shall not be entitled to, nor receive, from County, any additional consideration, compensation, salary, wages, or other type of remuneration for services rendered under this Agreement. Specifically, Contractor shall not be entitled, by virtue of this Agreement, to consideration in the form of overtime, health insurance benefits, retirement benefits, disability retirement benefits, sick leave, vacation time, paid holidays, or other paid leaves of absence of any type or kind whatsoever.

D. Limit upon amount payable under Agreement. The total sum of all payments made by the County to Contractor for services and work performed under this Agreement shall not exceed Six Thousand and no/100 Dollars \$ 6,000.00 (hereinafter referred to as "contract limit"). County expressly reserves the right to deny any payment or reimbursement requested by Contractor for services or work performed which is in excess of the contract limit.

County of Inyo Standard Contract – Lifeline Systems Company  
(Independent Contractor)

E. Billing and payment. Contractor shall submit to the County, once a month, an itemized statement of all services and work described in Attachment A, which were done at the County's request. This statement will be submitted to the County not later than the fifth (5th) day of the month. The statement to be submitted will cover the period from the first (1st) day of the preceding month through and including the last day of the preceding month. This statement will identify the date on which the services and work were performed and describe the nature of the services and work which were performed on each day. Upon timely receipt of the statement by the fifth (5th) day of the month, County shall make payment to Contractor on the last day of the month.

F. Federal and State taxes.

(1) Except as provided in subparagraph (2) below, County will not withhold any federal or state income taxes or social security from any payments made by County to Contractor under the terms and conditions of this Agreement.

(2) County will withhold California State income taxes from payments made under this Agreement to non-California resident independent contractors when it is anticipated that total annual payments to Contractor under this Agreement will exceed one thousand four hundred ninety nine dollars (\$1,499.00).

(3) Except as set forth above, County has no obligation to withhold any taxes or payments from sums paid by County to Contractor under this Agreement. Payment of all taxes and other assessments on such sums is the sole responsibility of Contractor. County has no responsibility or liability for payment of Contractor's taxes or assessments.

(4) The total amounts paid by County to Contractor, and taxes withheld from payments to non-California residents, if any, will be reported annually to the Internal Revenue Service and the California State Franchise Tax Board. To facilitate this reporting, Contractor shall complete and submit to the County an Internal Revenue Service (IRS) Form W-9 upon executing this Agreement.

**4. WORK SCHEDULE.**

Contractor's obligation is to perform, in a timely manner, those services and work identified in Attachment A which are requested by the County. It is understood by Contractor that the performance of these services and work will require a varied schedule. Contractor will arrange his/her own schedule, but will coordinate with County to ensure that all services and work requested by County under this Agreement will be performed within the time frame set forth by County.

**5. REQUIRED LICENSES, CERTIFICATES, AND PERMITS.**

A. Any licenses, certificates, or permits required by the federal, state, county, municipal governments, for contractor to provide the services and work described in Attachment A must be procured by Contractor and be valid at the time Contractor enters into this Agreement or as otherwise may be required. Further, during the term of this Agreement, Contractor must maintain such licenses, certificates, and permits in full force and effect. Licenses, certificates, and permits may include, but are not limited to, driver's licenses, professional licenses or certificates, and business licenses. Such licenses, certificates, and permits will be procured and maintained in force by Contractor at no expense to the County. Contractor will provide County, upon execution of this Agreement, with evidence of current and valid licenses, certificates and permits which are required to perform the services identified in Attachment A. Where there is a dispute between Contractor and County as to what licenses, certificates, and permits are required to perform the services identified in Attachment A, County reserves the right to make such determinations for purposes of this Agreement.

B. Contractor warrants that it is not presently debarred, suspended, proposed for debarment, declared ineligible, or voluntarily excluded from participation in covered transactions by any federal department or agency. Contractor also warrants that it is not suspended or debarred from receiving federal funds as listed in the List of Parties Excluded from Federal Procurement or Non-procurement Programs issued by the General Services Administration available at: <http://www.sam.gov>.

**6. OFFICE SPACE, SUPPLIES, EQUIPMENT, ET CETERA.**

Contractor shall provide such office space, supplies, equipment, vehicles, reference materials, and telephone service as is necessary for Contractor to provide the services identified in Attachment A to this Agreement. County is not obligated to reimburse or pay Contractor, for any expense or cost incurred by Contractor in procuring or maintaining such items. Responsibility for the costs and expenses incurred by Contractor in providing and maintaining such items is the sole responsibility and obligation of Contractor.

**7. COUNTY PROPERTY.**

A. Personal Property of County. Any personal property such as, but not limited to, protective or safety devices, badges, identification cards, keys, etc. provided to Contractor by County pursuant to this Agreement are, and at the termination of this Agreement remain, the sole and exclusive property of County. Contractor will use reasonable care to protect, safeguard and maintain such items while they are in Contractor's possession. Contractor will be financially responsible for any loss or damage to such items, partial or total, which is the result of Contractor's negligence.

B. Products of Contractor's Work and Services. Any and all compositions, publications, plans, designs, specifications, blueprints, maps, formulas, processes, photographs, slides, video tapes, computer programs, computer disks, computer tapes, memory chips, soundtracks, audio recordings, films, audio-visual presentations, exhibits, reports, studies, works of art, inventions, patents, trademarks, copyrights, or intellectual properties of any kind which are created, produced, assembled, compiled by, or are the result, product, or manifestation of, Contractor's services or work under this Agreement are, and at the termination of this Agreement remain, the sole and exclusive property of the County. At the termination of the Agreement, Contractor will convey possession and title to all such properties to County.

**8. INSURANCE.**

For the duration of this Agreement Contractor shall procure and maintain insurance of the scope and amount specified in Attachment C and with the provisions specified in that attachment.

**9. STATUS OF CONTRACTOR.**

All acts of Contractor, its agents, officers, and employees, relating to the performance of this Agreement, shall be performed as independent contractors, and not as agents, officers, or employees of County. Contractor, by virtue of this Agreement, has no authority to bind or incur any obligation on behalf of County. Except as expressly provided in Attachment A, Contractor has no authority or responsibility to exercise any rights or power vested in the County. No agent, officer, or employee of the Contractor is to be considered an employee of County. It is understood by both Contractor and County that this Agreement shall not under any circumstances be construed or considered to create an employer-employee relationship or a joint venture. As an independent contractor:

A. Contractor shall determine the method, details, and means of performing the work and services to be provided by Contractor under this Agreement.

B. Contractor shall be responsible to County only for the requirements and results specified in this Agreement, and except as expressly provided in this Agreement, shall not be subjected to County's control with respect to the physical action or activities of Contractor in fulfillment of this Agreement.

C. Contractor, its agents, officers, and employees are, and at all times during the term of this Agreement shall, represent and conduct themselves as independent contractors, and not as employees of County.

**10. DEFENSE AND INDEMNIFICATION.**

Contractor shall hold harmless, defend and indemnify County and its officers, officials, employees and volunteers from and against any and all liability, loss, damage, expense, costs (including without limitation costs and fees of litigation) of every nature arising out of or in connection with Contractor's

County of Inyo Standard Contract – Lifeline Systems Company  
(Independent Contractor)



performance of work hereunder or its failure to comply with any of its obligations contained in the agreement, except such loss or damages which was caused by the sole negligence or willful misconduct of the County. Contractor's obligation under this paragraph shall not include damages alleged by third parties who were not the actual clients/users of Contractor's products and services, as described in Attachment A (Scope of Work). Note: Contractor's obligations under this paragraph are independent from Contractor's obligations under this Agreement to procure and maintain certain insurance, as set forth in Attachment C, and nothing in this paragraph shall be construed as reducing or otherwise altering such insurance requirements or the County's rights related thereto.

**11. RECORDS AND AUDIT.**

A. Records. Contractor shall prepare and maintain all records required by the various provisions of this Agreement, federal, state, county, municipal, ordinances, regulations, and directions. Contractor shall maintain these records for a minimum of four (4) years from the termination or completion of this Agreement. Contractor may fulfill its obligation to maintain records as required by this paragraph by substitute photographs, microphotographs, or other authentic reproduction of such records.

B. Inspections and Audits. Any authorized representative of County shall have access to any books, documents, papers, records, including, but not limited to, financial records of Contractor, which County determines to be pertinent to this Agreement, for the purposes of making audit, evaluation, examination, excerpts, and transcripts during the period such records are to be maintained by Contractor. Further, County has the right, at all reasonable times, to audit, inspect, or otherwise evaluate the work performed or being performed under this Agreement.

**12. NONDISCRIMINATION.**

During the performance of this Agreement, Contractor, its agents, officers, and employees shall not unlawfully discriminate in violation of any federal, state, or local law, against any employee, or applicant for employment, or person receiving services under this Agreement, because of race, religion, color, national origin, ancestry, physical handicap, medical condition, marital status, age, or sex. Contractor and its agents, officers, and employees shall comply with the provisions of the Fair Employment and Housing Act (Government Code section 12900, et seq.), and the applicable regulations promulgated thereunder in the California Code of Regulations. Contractor shall also abide by the Federal Civil Rights Act of 1964 (P.L. 88-352) and all amendments thereto, and all administrative rules and regulations issued pursuant to said act.

**13. CANCELLATION.**

This Agreement may be canceled by County without cause, and at will, for any reason by giving to Contractor thirty (30) days written notice of such intent to cancel. Contractor may cancel this Agreement without cause, and at will, for any reason whatsoever by giving thirty (30) days written notice of such intent to cancel to County.

**14. ASSIGNMENT.**

This is an agreement for the services of Contractor. County has relied upon the skills, knowledge, experience, and training of Contractor as an inducement to enter into this Agreement. Contractor shall not assign or subcontract this Agreement, or any part of it, without the express written consent of County. Further, Contractor shall not assign any monies due or to become due under this Agreement without the prior written consent of County.

**15. DEFAULT.**

If the Contractor abandons the work, or fails to proceed with the work and services requested by County in a timely manner, or fails in any way as required to conduct the work and services as required by

County, County may declare the Contractor in default and terminate this Agreement upon five (5) days written notice to Contractor. Upon such termination by default, County will pay to Contractor all amounts owing to Contractor for services and work satisfactorily performed to the date of termination.

**16. WAIVER OF DEFAULT.**

Waiver of any default by either party to this Agreement shall not be deemed to be waiver of any subsequent default. Waiver or breach of any provision of this Agreement shall not be deemed to be a waiver of any other or subsequent breach, and shall not be construed to be a modification of the terms of this Agreement unless this Agreement is modified as provided in paragraph twenty-two (22) below.

**17. CONFIDENTIALITY.**

Contractor further agrees to comply with the various provisions of the federal, state, and county laws, regulations, and ordinances providing that information and records kept, maintained, or accessible by Contractor in the course of providing services and work under this Agreement, shall be privileged, restricted, or confidential. Contractor agrees to keep confidential all such information and records. Disclosure of such confidential, privileged, or protected information shall be made by Contractor only with the express written consent of the County. Any disclosure of confidential information by Contractor without the County's written consent is solely and exclusively the legal responsibility of Contractor in all respects.

Notwithstanding anything in the Agreement to the contrary, names of persons receiving public social services are confidential and are to be protected from unauthorized disclosure in accordance with Title 45, Code of Federal Regulations Section 205.50, the Health Insurance Portability and Accountability Act of 1996, and Sections 10850 and 14100.2 of the Welfare and Institutions Code, and regulations adopted pursuant thereto. For the purpose of this Agreement, all information, records, and data elements pertaining to beneficiaries shall be protected by the provider from unauthorized disclosure.

**18. CONFLICTS.**

Contractor agrees that it has no interest, and shall not acquire any interest, direct or indirect, which would conflict in any manner or degree with the performance of the work and services under this Agreement.

**19. POST AGREEMENT COVENANT.**

Contractor agrees not to use any confidential, protected, or privileged information which is gained from the County in the course of providing services and work under this Agreement, for any personal benefit, gain, or enhancement. Further, Contractor agrees for a period of two years after the termination of this Agreement, not to seek or accept any employment with any entity, association, corporation, or person who, during the term of this Agreement, has had an adverse or conflicting interest with the County, or who has been an adverse party in litigation with the County, and concerning such, Contractor by virtue of this Agreement has gained access to the County's confidential, privileged, protected, or proprietary information.

**20. SEVERABILITY.**

If any portion of this Agreement or application thereof to any person or circumstance shall be declared invalid by a court of competent jurisdiction, or if it is found in contravention of any federal, state, or county statute, ordinance, or regulation, the remaining provisions of this Agreement, or the application thereof, shall not be invalidated thereby, and shall remain in full force and effect to the extent that the provisions of this Agreement are severable.

**21. FUNDING LIMITATION.**

The ability of County to enter this Agreement is based upon available funding from various sources. In the event that such funding fails, is reduced, or is modified, from one or more sources, County has the option to cancel, reduce, or modify this Agreement, or any of its terms within ten (10) days of its notifying Contractor of the cancellation, reduction, or modification of available funding. Any reduction or modification of this Agreement made pursuant to this provision must comply with the requirements of paragraph twenty-two (22) (Amendment).

**22. AMENDMENT.**

This Agreement may be modified, amended, changed, added to, or subtracted from, by the mutual consent of the parties hereto, if such amendment or change is in written form and executed with the same formalities as this Agreement, and attached to the original Agreement to maintain continuity.

**23. NOTICE.**

Any notice, communication, amendments, additions, or deletions to this Agreement, including change of address of either party during the terms of this Agreement, which Contractor or County shall be required, or may desire, to make, shall be in writing and may be personally served, or sent by prepaid first class mail to, the respective parties as follows:

County of Inyo  
Health and Human Services Department  
162 J Grove Street Address  
Bishop, CA 93514 City and State

Contractor:  
Lifeline Systems Company Name  
111 Lawrence Street Address  
Framingham, MA 01702 City and State

**24. ENTIRE AGREEMENT.**

This Agreement contains the entire agreement of the parties, and no representations, inducements, promises, or agreements otherwise between the parties not embodied herein or incorporated herein by reference, shall be of any force or effect. Further, no term or provision hereof may be changed, waived, discharged, or terminated, unless the same be in writing executed by the parties hereto.

////

////

**AGREEMENT BETWEEN COUNTY OF INYO  
AND Lifeline Systems Company**  
**FOR THE PROVISION OF Emergency Response Monitoring SERVICES**

IN WITNESS THEREOF, THE PARTIES HERETO HAVE SET THEIR HANDS AND SEALS  
THIS \_\_\_\_\_ DAY OF \_\_\_\_\_, \_\_\_\_\_.

**COUNTY OF INYO**

**CONTRACTOR**

By: \_\_\_\_\_  
Signature

By: Stephen Weir  
Signature

\_\_\_\_\_  
Print or Type Name

Stephen Weir, Manager, PHM Contracts  
\_\_\_\_\_  
Print or Type Name

Dated: \_\_\_\_\_

Dated: 10-22-2020

APPROVED AS TO FORM AND LEGALITY:

County Counsel



APPROVED AS TO ACCOUNTING FORM:

\_\_\_\_\_  
County Auditor

APPROVED AS TO PERSONNEL REQUIREMENTS:

\_\_\_\_\_  
Personnel Services

APPROVED AS TO INSURANCE REQUIREMENTS:

\_\_\_\_\_  
County Risk Manager

**ATTACHMENT A**

**AGREEMENT BETWEEN COUNTY OF INYO  
AND LIFELINE SYSTEM COMPANY  
FOR THE PROVISION OF EMERGENCY RESPONSE MONITORING SERVICES**

**TERM:**

**FROM:** July 1, 2020      **TO:** June 30, 2021

**SCOPE OF WORK:**

Contractor agrees to provide Eastern Sierra Area Agency on Aging (ESAAA) with emergency response monitoring services for up to thirty (30) frail individuals in need of said services as determined by ESAAA. Emergency monitoring services include the installation of Care Partner 68000, 95000\* unit, continuous monitoring of individual units and telephone response to client sending unit signal with two (2) minutes. Contractor will obtain and maintain individual client data in database and respond to emergencies as specified in client records and company policies, incorporated herein by reference.

\*The Care Partner 9500 offers an option to provide reminders to clients and an option to monitor whether those reminders were acted upon. Rates for these additional services are specified in Attachment B. Contractor agrees to keep all clients information confidential and will only share that information as allowed by applicable state and federal laws. Care Partner 9500 units will be available for existing Care Partners 9500 clients. No new clients will be added beyond contracted thirty (30).

Contractor will provide activity and services requested reports to ESAAA on a monthly basis.

**ATTACHMENT B**

**AGREEMENT BETWEEN COUNTY OF INYO  
AND LIFELINE SYSTEM COMPANY  
FOR THE PROVISION OF EMERGENCY RESPONSE MONITORING SERVICES**

**TERM:**  
FROM: July 1, 2020 TO: June 30, 2021

**SCHEDULE OF FEES:**

Contractor will monitor up to thirty (30) units at the rates specified below, in an amount not to exceed \$6,000.00 for the period of **July 1, 2020 to June 30, 2021**. An installation fee of \$25.00 will be charged for the installation of new units. New units will remain the property of the Contractor and the monthly fees include all lease or rental charges.

Lifeline Care Partner, 6800 = \$20.00/month\*\*

Contractor must be able to document that funds granted under this agreement were spent in accordance with applicable laws, regulations and conditions cited in Inyo County's Health and Human Services contract with the California Department of Aging, which are incorporated herein by reference.

\*\*For existing Care Partner 9500 clients only (as indicated in Attachment A)

**ATTACHMENT C**

**AGREEMENT BETWEEN COUNTY OF INYO  
AND LIFELINE SYSTEM COMPANY  
FOR THE PROVISION OF EMERGENCY RESPONSE MONITORING SERVICES**

**TERM:**

**FROM:** July 1, 2020 **TO:** June 30, 2021

**SEE ATTACHED INSURANCE PROVISIONS**



**Specifications 4**  
**Insurance Requirements for Vendors**

Vendor shall procure and maintain for the duration of the contract insurance against claims for injuries to persons or damages to property which may arise from or in connection with products and materials supplied to the Entity. The cost of such insurance shall be borne by the Vendor.

**MINIMUM SCOPE AND LIMIT OF INSURANCE**

Coverage shall be at least as broad as Insurance Services Office Commercial General Liability coverage (occurrence Form CG 00 01) and include products coverage.

***Minimum Limits of Insurance***

Vendor shall maintain limits no less than \$1,000,000 per occurrence for bodily injury and property damage, and an aggregate limit of \$2,000,000.

If the Vendor maintains higher limits than the minimums shown above, the Entity requires and shall be entitled to coverage for the higher limits maintained by the contractor.

***Deductibles and Self-Insured Retentions***

Any deductibles or self-insured retentions must be declared to and approved by the Entity. At the option of the Entity, either: the Vendor shall obtain coverage to reduce or eliminate such deductibles or self-insured retentions as respects the Entity, its officers, officials, employees, and volunteers; or the Vendor shall provide a financial guarantee satisfactory to the Entity guaranteeing payment of losses and related investigations, claim administration, and defense expenses.

***Other Insurance Provisions***

The policy or policies are to contain, or be endorsed to contain, the following provisions:

1. The Entity, its officers, officials, employees, and volunteers are to be covered as additional insureds as respects products of the Vendor.
2. The Vendor's insurance coverage shall be primary insurance as respects the Entity, its officers, officials, employees and volunteers. Any insurance or self-insurance maintained by the Entity, its officers, officials, employees or volunteers, shall be excess of the Vendor's insurance and shall not contribute with it.
3. Each insurance policy required by this clause shall state that coverage shall not be canceled, except after thirty (30) days prior written notice has been provided to the Entity.

***Acceptability of Insurers***

Insurance is to be placed with insurers with a current A.M. Best's rating of no less than A:VII, unless otherwise acceptable to the Entity.

***Verification of Coverage***

Vendor shall furnish the Entity with original certificates and amendatory endorsements or copies of the applicable policy language providing the insurance coverage required above. All certificates and endorsements are to be received and approved by the Entity before work commences. However, failure to obtain the required documents prior to the work beginning

shall not waive the Vendor's obligation to provide them. The Entity reserves the right to require complete, certified copies of all required insurance policies, including endorsements required by these specifications, at any time.

***Waiver of Subrogation***

Vendor hereby grants to Entity a waiver of any right to subrogation which any insurer of said Vendor may acquire against the Entity by virtue of the payment of any loss under such insurance. Vendor agrees to obtain any endorsement that may be necessary to effect this waiver of subrogation, but this provision applies regardless of whether or not the Entity has received a waiver of subrogation endorsement from the insurer

***Special Risks or Circumstances***

Entity reserves the right to modify these requirements at any time, including limits, based on the nature of the risk, prior experience, insurer, coverage, or other special circumstances.

## **Attachment B: Insurance Requirements for Professional Services**

Contractor shall procure and maintain for the duration of the contract insurance against claims for injuries to persons or damages to property which may arise from or in connection with the performance of the work hereunder by the Contractor, its agents, representatives, or employees.

### **MINIMUM SCOPE AND LIMIT OF INSURANCE**

Coverage shall be at least as broad as:

**Commercial General Liability (CGL):** Insurance Services Office Form CG 00 01 covering CGL on an "occurrence" basis, including products and completed operations, property damage, bodily injury and personal & advertising injury with limits no less than \$1,000,000 per occurrence, \$2,000,000 general aggregate.

Additional Insured Status. Inyo County, its officers, officials, employees, and volunteers are to be covered as additional insureds on the CGL policy with respect to liability arising out of work or operations performed by or on behalf of the Vendor including materials, parts, or equipment furnished in connection with such work or operations. General liability coverage can be provided in the form of an endorsement to the Contractor's insurance (at least as broad as ISO Form CG 20 10 11 85 or both CG 20 10, CG 20 26, CG 20 33, or CG 20 38; and CG 20 37 forms if later revisions used).

**Automobile Liability:** Insurance Services Office Form Number CA 0001 covering, Code 1 (any auto), or if Contractor has no owned autos, Code 8 (hired) and 9 (non-owned), with limit no less than \$1,000,000 per accident for bodily injury and property damage.

**Workers' Compensation:** as required by the State of California, with Statutory Limits, and Employer's Liability Insurance with limit of no less than \$1,000,000 per accident for bodily injury or disease. May be waived with signed letter on contractor's letterhead certifying that contractor has no employees.

**Professional Liability (Errors and Omissions):** appropriate to the Contractor's profession, with limit no less than \$1,000,000 per occurrence or claim, \$2,000,000 aggregate.

**Cyber Liability Insurance,** with limits not less than \$1,000,000 per occurrence or claim, \$2,000,000 aggregate. Cyber liability requirement may be waived if contractor will not be receiving/storing/transmitting personally identifiable information (PII) or personal medical information (PMI). Coverage shall be sufficiently broad to respond to the duties and obligations as is undertaken by contractor in this agreement and shall include, but not be limited to, claims involving infringement of intellectual property, including but not limited to infringement of copyright, trademark, trade dress, invasion of privacy violations, information theft, damage to or destruction of electronic information, release of private information, alteration of electronic information, extortion and network security. The policy shall provide coverage for breach response costs as well as regulatory fines and penalties as well as credit monitoring expenses with limits sufficient to respond to these obligations.

If the Contractor maintains broader coverage and/or higher limits than the minimums shown above, Inyo County requires and shall be entitled to the broader coverage and/or the higher

## **Attachment B: Insurance Requirements for Professional Services**

limits maintained by the contractor. Any available insurance proceeds in excess of the specified minimum limits of insurance and coverage shall be available to Inyo County.

### **OTHER INSURANCE PROVISIONS**

The insurance policies are to contain, or be endorsed to contain, the following provisions:

#### **Primary Coverage**

For any claims related to this contract, the Contractor's insurance coverage shall be primary insurance primary coverage at least as broad as ISO CG 20 01 04 13 as respects Inyo County, its officers, officials, employees, and volunteers. Any insurance or self-insurance maintained by Inyo County, its officers, officials, employees, or volunteers shall be excess of the Contractor's insurance and shall not contribute with it.

#### **Notice of Cancellation**

Each insurance policy required above shall state that coverage shall not be canceled, except with notice to Inyo County.

#### **Waiver of Subrogation**

Contractor hereby grants to Inyo County a waiver of any right to subrogation which any insurer of said Contractor may acquire against Inyo County by virtue of the payment of any loss under such insurance. Contractor agrees to obtain any endorsement that may be necessary to affect this waiver of subrogation, but this provision applies regardless of whether or not Inyo County has received a waiver of subrogation endorsement from the insurer.

#### **Self-Insured Retentions**

Self-insured retentions must be declared to and approved by Inyo County. Inyo County may require the Contractor to provide proof of ability to pay losses and related investigations, claim administration, and defense expenses within the retention. The policy language shall provide, or be endorsed to provide, that the self-insured retention may be satisfied by either the named insured or Inyo County.

#### **Acceptability of Insurers**

Insurance is to be placed with insurers authorized to conduct business in the state with a current A.M. Best's rating of no less than A:VII, unless otherwise acceptable to Inyo County.

#### **Claims Made Policies**

If any of the required policies provide coverage on a claims-made basis:

1. The Retroactive Date must be shown and must be before the date of the contract or the beginning of contract work.
2. Insurance must be maintained and evidence of insurance must be provided for at least five (5) years after completion of the contract of work.
3. If coverage is canceled or non-renewed, and not replaced with another claims-made policy form with a Retroactive Date prior to the contract effective date, the Contractor must purchase "extended reporting" coverage for a minimum of five (5) years after completion of contract work.

## **Attachment B: Insurance Requirements for Professional Services**

### **Verification of Coverage**

Contractor shall furnish Inyo County with original Certificates of Insurance including all required amendatory endorsements (or copies of the applicable policy language effecting coverage required by this clause) and a copy of the Declarations and Endorsement Page of the CGL policy listing all policy endorsements to Inyo County before work begins. However, failure to obtain the required documents prior to the work beginning shall not waive the Contractor's obligation to provide them. Inyo County reserves the right to require complete, certified copies of all required insurance policies, including endorsements required by these specifications, at any time.

### **Subcontractors**

Contractor shall require and verify that all subcontractors maintain insurance meeting all the requirements stated herein, and Contractor shall ensure that Inyo County is an additional insured on insurance required from subcontractors.

### **Special Risks or Circumstances**

Inyo County reserves the right to modify these requirements, including limits, based on the nature of the risk, prior experience, insurer, coverage, or other special circumstances.

-end-

## Attachment B: Insurance Requirements for Professional Services

Contractor shall procure and maintain for the duration of the contract insurance against claims for injuries to persons or damages to property which may arise from or in connection with the performance of the work hereunder by the Contractor, its agents, representatives, or employees.

### MINIMUM SCOPE AND LIMIT OF INSURANCE

Coverage shall be at least as broad as:

**Commercial General Liability (CGL):** Insurance Services Office Form CG 00 01 covering CGL on an "occurrence" basis, including products and completed operations, property damage, bodily injury and personal & advertising injury with limits no less than \$1,000,000 per occurrence, \$2,000,000 general aggregate.

Additional Insured Status. Inyo County, its officers, officials, employees, and volunteers are to be covered as additional insureds on the CGL policy with respect to liability arising out of work or operations performed by or on behalf of the Vendor including materials, parts, or equipment furnished in connection with such work or operations. General liability coverage can be provided in the form of an endorsement to the Contractor's insurance (at least as broad as ISO Form CG 20 10 11 85 or both CG 20 10, CG 20 26, CG 20 33, or CG 20 38; and CG 20 37 forms if later revisions used).

**Automobile Liability:** Insurance Services Office Form Number CA 0001 covering, Code 1 (any auto), or if Contractor has no owned autos, Code 8 (hired) and 9 (non-owned), with limit no less than \$1,000,000 per accident for bodily injury and property damage.

**Workers' Compensation:** as required by the State of California, with Statutory Limits, and Employer's Liability Insurance with limit of no less than \$1,000,000 per accident for bodily injury or disease. May be waived with signed letter on contractor's letterhead certifying that contractor has no employees.

**Professional Liability (Errors and Omissions):** appropriate to the Contractor's profession, with limit no less than \$1,000,000 per occurrence or claim, \$2,000,000 aggregate.

**Cyber Liability Insurance,** with limits not less than \$1,000,000 per occurrence or claim, \$2,000,000 aggregate. Cyber liability requirement may be waived if contractor will not be receiving/storing/transmitting personally identifiable information (PII) or personal medical information (PMI). Coverage shall be sufficiently broad to respond to the duties and obligations as is undertaken by contractor in this agreement and shall include, but not be limited to, claims involving infringement of intellectual property, including but not limited to infringement of copyright, trademark, trade dress, invasion of privacy violations, information theft, damage to or destruction of electronic information, release of private information, alteration of electronic information, extortion and network security. The policy shall provide coverage for breach response costs as well as regulatory fines and penalties as well as credit monitoring expenses with limits sufficient to respond to these obligations.

If the Contractor maintains broader coverage and/or higher limits than the minimums shown above, Inyo County requires and shall be entitled to the broader coverage and/or the higher

## **Attachment B: Insurance Requirements for Professional Services**

limits maintained by the contractor. Any available insurance proceeds in excess of the specified minimum limits of insurance and coverage shall be available to Inyo County.

### **OTHER INSURANCE PROVISIONS**

The insurance policies are to contain, or be endorsed to contain, the following provisions:

#### **Primary Coverage**

For any claims related to this contract, the Contractor's insurance coverage shall be primary insurance primary coverage at least as broad as ISO CG 20 01 04 13 as respects Inyo County, its officers, officials, employees, and volunteers. Any insurance or self-insurance maintained by Inyo County, its officers, officials, employees, or volunteers shall be excess of the Contractor's insurance and shall not contribute with it.

#### **Notice of Cancellation**

Each insurance policy required above shall state that coverage shall not be canceled, except with notice to Inyo County.

#### **Waiver of Subrogation**

Contractor hereby grants to Inyo County a waiver of any right to subrogation which any insurer of said Contractor may acquire against Inyo County by virtue of the payment of any loss under such insurance. Contractor agrees to obtain any endorsement that may be necessary to affect this waiver of subrogation, but this provision applies regardless of whether or not Inyo County has received a waiver of subrogation endorsement from the insurer.

#### **Self-Insured Retentions**

Self-insured retentions must be declared to and approved by Inyo County. Inyo County may require the Contractor to provide proof of ability to pay losses and related investigations, claim administration, and defense expenses within the retention. The policy language shall provide, or be endorsed to provide, that the self-insured retention may be satisfied by either the named insured or Inyo County.

#### **Acceptability of Insurers**

Insurance is to be placed with insurers authorized to conduct business in the state with a current A.M. Best's rating of no less than A:VII, unless otherwise acceptable to Inyo County.

#### **Claims Made Policies**

If any of the required policies provide coverage on a claims-made basis:

1. The Retroactive Date must be shown and must be before the date of the contract or the beginning of contract work.
2. Insurance must be maintained and evidence of insurance must be provided for at least five (5) years after completion of the contract of work.
3. If coverage is canceled or non-renewed, and not replaced with another claims-made policy form with a Retroactive Date prior to the contract effective date, the Contractor must purchase "extended reporting" coverage for a minimum of five (5) years after completion of contract work.



## **Attachment B: Insurance Requirements for Professional Services**

### **Verification of Coverage**

Contractor shall furnish Inyo County with original Certificates of Insurance including all required amendatory endorsements (or copies of the applicable policy language effecting coverage required by this clause) and a copy of the Declarations and Endorsement Page of the CGL policy listing all policy endorsements to Inyo County before work begins. However, failure to obtain the required documents prior to the work beginning shall not waive the Contractor's obligation to provide them. Inyo County reserves the right to require complete, certified copies of all required insurance policies, including endorsements required by these specifications, at any time.

### **Subcontractors**

Contractor shall require and verify that all subcontractors maintain insurance meeting all the requirements stated herein, and Contractor shall ensure that Inyo County is an additional insured on insurance required from subcontractors.

### **Special Risks or Circumstances**

Inyo County reserves the right to modify these requirements, including limits, based on the nature of the risk, prior experience, insurer, coverage, or other special circumstances.

-end-



# County of Inyo



## Health & Human Services - Social Services

### DEPARTMENTAL - ACTION REQUIRED

**MEETING:** November 3, 2020

**FROM:** Tyler Davis

**SUBJECT:** Approve and Ratify Contract with Redwood Toxicology Laboratory for November 1, 2020 through June 30, 2024.

---

**RECOMMENDED ACTION:**

Request Board award, ratify and approve the contract for the provision of urine sample collection devices (supplies) and laboratory services with Redwood Toxicology Laboratory, Inc. of Santa Rosa, CA in an amount not to exceed \$60,000 for the period of November 1, 2020 through June 30, 2024, contingent upon the Board's adoption of future budgets, and authorize the Chairperson to sign, contingent upon all appropriate signatures being obtained.

**SUMMARY/JUSTIFICATION:**

HHS advertised a Request for Proposals for drug testing supplies and services for Inyo County HHS' Child Protective Services and Substance Use Disorders programs. After receiving bids from three vendors, Redwood was determined to meet our RFP requirements and be the least expensive overall cost. The supply cost for Redwood is slightly higher than one of the other vendors, but the testing results are significantly less expensive with Redwood, resulting in Redwood providing a bid with an overall lower cost to the County. HHS has already been using Redwood Toxicology for over three years for these services. Drug testing supplies and services are mandated services in our CPS and SUD programs. Some of these expenses are claimed and reimbursed in our Social Services program.

**BACKGROUND/HISTORY OF BOARD ACTIONS:**

N/A

**ALTERNATIVES AND CONSEQUENCES OF NEGATIVE ACTION:**

Not approving this contract would cause a delay in the ability to provide mandated services, as well as reduce the ability of CPS to effectively monitor a critical safety factor involved in most of the child welfare cases.

**OTHER AGENCY INVOLVEMENT:**

None

**FINANCING:**

Monies have been budgeted in Social Services (055800) in Object Code (5265) Professional Services and in SUD (045315) in Object Code (5311) General Operating. No General Fund monies will be used.

**ATTACHMENTS:**

1. Redwood Toxicology Contract

**APPROVALS:**

Tyler Davis	Created/Initiated - 10/26/2020
Darcy Ellis	Approved - 10/27/2020
Keri Oney	Approved - 10/28/2020
Melissa Best-Baker	Approved - 10/28/2020
Marilyn Mann	Approved - 10/28/2020
Marshall Rudolph	Approved - 10/29/2020
Marilyn Mann	Approved - 10/29/2020
Amy Shepherd	Final Approval - 10/29/2020

**AGREEMENT BETWEEN COUNTY OF INYO**

**AND** Redwood Toxicology Laboratory  
**FOR THE PROVISION OF** Drug Testing and Supply **SERVICES**

**INTRODUCTION**

WHEREAS, the County of Inyo (hereinafter referred to as "County") may have the need for the drug testing and supply services of Redwood Toxicology Laboratory of Santa Rosa, CA (hereinafter referred to as "Contractor"), and in consideration of the mutual promises, covenants, terms, and conditions hereinafter contained, the parties hereby agree as follows:

**TERMS AND CONDITIONS**

**1. SCOPE OF WORK.**

The Contractor shall furnish to the County, upon its request, those services and work set forth in Attachment A, attached hereto and by reference incorporated herein. Requests by the County to the Contractor to perform under this Agreement will be made by Keri Oney, whose title is: Deputy Director Aging and Social Service. Requests to the Contractor for work or services to be performed under this Agreement will be based upon the County's need for such services. The County makes no guarantee or warranty, of any nature, that any minimum level or amount of services or work will be requested of the Contractor by the County under this Agreement. County by this Agreement incurs no obligation or requirement to request from Contractor the performance of any services or work at all, even if County should have some need for such services or work during the term of this Agreement.

Services and work provided by the Contractor at the County's request under this Agreement will be performed in a manner consistent with the requirements and standards established by applicable federal, state, and County laws, ordinances, regulations, and resolutions. Such laws, ordinances, regulations, and resolutions include, but are not limited to, those which are referred to in this Agreement.

**2. TERM.**

The term of this Agreement shall be from November 1, 2020 to June 30, 2024 unless sooner terminated as provided below.

**3. CONSIDERATION.**

A. Compensation. County shall pay to Contractor in accordance with the Schedule of Fees (set forth as Attachment B) for the services and work described in Attachment A which are performed by Contractor at the County's request.

B. Travel and per diem. Contractor will not be paid or reimbursed for travel expenses or per diem which Contractor incurs in providing services and work requested by County under this Agreement.

C. No additional consideration. Except as expressly provided in this Agreement, Contractor shall not be entitled to, nor receive, from County, any additional consideration, compensation, salary, wages, or other type of remuneration for services rendered under this Agreement. Specifically, Contractor shall not be entitled, by virtue of this Agreement, to consideration in the form of overtime, health insurance benefits, retirement benefits, disability retirement benefits, sick leave, vacation time, paid holidays, or other paid leaves of absence of any type or kind whatsoever.

D. Limit upon amount payable under Agreement. The total sum of all payments made by the County to Contractor for services and work performed under this Agreement shall not exceed \$60,000 (sixty thousand dollars and no/xx) Dollars

(\$ 60,000.00) (hereinafter referred to as "contract limit"). County expressly reserves the right to deny any payment or reimbursement requested by Contractor for services or work performed which is in excess of the contract limit.

E. Billing and payment. Contractor shall submit to the County, once a month, an itemized statement of all services and work described in Attachment A, which were done at the County's request. This statement will be submitted to the County not later than the fifth (5th) day of the month. The statement to be submitted will cover the period from the first (1st) day of the preceding month through and including the last day of the preceding month. This statement will identify the date on which the services and work were performed and describe the nature of the services and work which were performed on each day. Upon timely receipt of the statement by the fifth (5th) day of the month, County shall make payment to Contractor on the last day of the month.

F. Federal and State taxes.

(1) Except as provided in subparagraph (2) below, County will not withhold any federal or state income taxes or social security from any payments made by County to Contractor under the terms and conditions of this Agreement.

(2) County will withhold California State income taxes from payments made under this Agreement to non-California resident independent contractors when it is anticipated that total annual payments to Contractor under this Agreement will exceed one thousand four hundred ninety nine dollars (\$1,499.00).

(3) Except as set forth above, County has no obligation to withhold any taxes or payments from sums paid by County to Contractor under this Agreement. Payment of all taxes and other assessments on such sums is the sole responsibility of Contractor. County has no responsibility or liability for payment of Contractor's taxes or assessments.

(4) The total amounts paid by County to Contractor, and taxes withheld from payments to non-California residents, if any, will be reported annually to the Internal Revenue Service and the California State Franchise Tax Board. To facilitate this reporting, Contractor shall complete and submit to the County an Internal Revenue Service (IRS) Form W-9 upon executing this Agreement.

#### **4. WORK SCHEDULE.**

Contractor's obligation is to perform, in a timely manner, those services and work identified in Attachment A which are requested by the County. It is understood by Contractor that the performance of these services and work will require a varied schedule. Contractor will arrange his/her own schedule, but will coordinate with County to ensure that all services and work requested by County under this Agreement will be performed within the time frame set forth by County.

#### **5. REQUIRED LICENSES, CERTIFICATES, AND PERMITS.**

A. Any licenses, certificates, or permits required by the federal, state, county, municipal governments, for contractor to provide the services and work described in Attachment A must be procured by Contractor and be valid at the time Contractor enters into this Agreement or as otherwise may be required. Further, during the term of this Agreement, Contractor must maintain such licenses, certificates, and permits in full force and effect. Licenses, certificates, and permits may include, but are not limited to, driver's licenses, professional licenses or certificates, and business licenses. Such licenses, certificates, and permits will be procured and maintained in force by Contractor at no expense to the County. Contractor will provide County, upon execution of this Agreement, with evidence of current and valid licenses, certificates and permits which are required to perform the services identified in Attachment A. Where there is a dispute between Contractor and County as to what licenses, certificates, and permits are required to perform the services identified in Attachment A, County reserves the right to make such determinations for purposes of this Agreement.

B. Contractor warrants that it is not presently debarred, suspended, proposed for debarment, declared ineligible, or voluntarily excluded from participation in covered transactions by any federal department or agency. Contractor also warrants that it is not suspended or debarred from receiving federal funds as listed in the List of Parties Excluded from Federal Procurement or Non-procurement Programs issued by the General Services Administration available at: <http://www.sam.gov>.

**6. OFFICE SPACE, SUPPLIES, EQUIPMENT, ET CETERA.**

Contractor shall provide such office space, supplies, equipment, vehicles, reference materials, and telephone service as is necessary for Contractor to provide the services identified in Attachment A to this Agreement. County is not obligated to reimburse or pay Contractor, for any expense or cost incurred by Contractor in procuring or maintaining such items. Responsibility for the costs and expenses incurred by Contractor in providing and maintaining such items is the sole responsibility and obligation of Contractor.

**7. COUNTY PROPERTY.**

A. Personal Property of County. Any personal property such as, but not limited to, protective or safety devices, badges, identification cards, keys, etc. provided to Contractor by County pursuant to this Agreement are, and at the termination of this Agreement remain, the sole and exclusive property of County. Contractor will use reasonable care to protect, safeguard and maintain such items while they are in Contractor's possession. Contractor will be financially responsible for any loss or damage to such items, partial or total, which is the result of Contractor's negligence.

B. Products of Contractor's Work and Services. Any and all compositions, publications, plans, designs, specifications, blueprints, maps, formulas, processes, photographs, slides, video tapes, computer programs, computer disks, computer tapes, memory chips, soundtracks, audio recordings, films, audio-visual presentations, exhibits, reports, studies, works of art, inventions, patents, trademarks, copyrights, or intellectual properties of any kind which are created, produced, assembled, compiled by, or are the result, product, or manifestation of, Contractor's services or work under this Agreement are, and at the termination of this Agreement remain, the sole and exclusive property of the County. At the termination of the Agreement, Contractor will convey possession and title to all such properties to County.

**8. INSURANCE.**

For the duration of this Agreement Contractor shall procure and maintain insurance of the scope and amount specified in Attachment C and with the provisions specified in that attachment.

**9. STATUS OF CONTRACTOR.**

All acts of Contractor, its agents, officers, and employees, relating to the performance of this Agreement, shall be performed as independent contractors, and not as agents, officers, or employees of County. Contractor, by virtue of this Agreement, has no authority to bind or incur any obligation on behalf of County. Except as expressly provided in Attachment A, Contractor has no authority or responsibility to exercise any rights or power vested in the County. No agent, officer, or employee of the Contractor is to be considered an employee of County. It is understood by both Contractor and County that this Agreement shall not under any circumstances be construed or considered to create an employer-employee relationship or a joint venture. As an independent contractor:

A. Contractor shall determine the method, details, and means of performing the work and services to be provided by Contractor under this Agreement.

B. Contractor shall be responsible to County only for the requirements and results specified in this Agreement, and except as expressly provided in this Agreement, shall not be subjected to County's control with respect to the physical action or activities of Contractor in fulfillment of this Agreement.

C. Contractor, its agents, officers, and employees are, and at all times during the term of this Agreement shall, represent and conduct themselves as independent contractors, and not as employees of County.

**10. DEFENSE AND INDEMNIFICATION.**

Contractor shall hold harmless, defend and indemnify County and its officers, officials, employees and volunteers from and against any and all liability, loss, damage, expense, costs (including without limitation costs and fees of litigation) of every nature arising out of or in connection with Contractor's performance of work hereunder or its failure to comply with any of its obligations contained in the agreement, except such loss or damages which was caused by the sole negligence or willful misconduct of the County.

**11. RECORDS AND AUDIT.**

A. Records. Contractor shall prepare and maintain all records required by the various provisions of this Agreement, federal, state, county, municipal, ordinances, regulations, and directions. Contractor shall maintain these records for a minimum of four (4) years from the termination or completion of this Agreement. Contractor may fulfill its obligation to maintain records as required by this paragraph by substitute photographs, microphotographs, or other authentic reproduction of such records.

B. Inspections and Audits. Any authorized representative of County shall have access to any books, documents, papers, records, including, but not limited to, financial records of Contractor, which County determines to be pertinent to this Agreement, for the purposes of making audit, evaluation, examination, excerpts, and transcripts during the period such records are to be maintained by Contractor. Further, County has the right, at all reasonable times, to audit, inspect, or otherwise evaluate the work performed or being performed under this Agreement.

**12. NONDISCRIMINATION.**

During the performance of this Agreement, Contractor, its agents, officers, and employees shall not unlawfully discriminate in violation of any federal, state, or local law, against any employee, or applicant for employment, or person receiving services under this Agreement, because of race, religion, color, national origin, ancestry, physical handicap, medical condition, marital status, age, or sex. Contractor and its agents, officers, and employees shall comply with the provisions of the Fair Employment and Housing Act (Government Code section 12900, et seq.), and the applicable regulations promulgated thereunder in the California Code of Regulations. Contractor shall also abide by the Federal Civil Rights Act of 1964 (P.L. 88-352) and all amendments thereto, and all administrative rules and regulations issued pursuant to said act.

**13. CANCELLATION.**

This Agreement may be canceled by County without cause, and at will, for any reason by giving to Contractor thirty (30) days written notice of such intent to cancel. Contractor may cancel this Agreement without cause, and at will, for any reason whatsoever by giving thirty (30) days written notice of such intent to cancel to County.

**14. ASSIGNMENT.**

This is an agreement for the services of Contractor. County has relied upon the skills, knowledge, experience, and training of Contractor as an inducement to enter into this Agreement. Contractor shall not assign or subcontract this Agreement, or any part of it, without the express written consent of County. Further, Contractor shall not assign any monies due or to become due under this Agreement without the prior written consent of County.



**15. DEFAULT.**

If the Contractor abandons the work, or fails to proceed with the work and services requested by County in a timely manner, or fails in any way as required to conduct the work and services as required by County, County may declare the Contractor in default and terminate this Agreement upon five (5) days written notice to Contractor. Upon such termination by default, County will pay to Contractor all amounts owing to Contractor for services and work satisfactorily performed to the date of termination.

**16. WAIVER OF DEFAULT.**

Waiver of any default by either party to this Agreement shall not be deemed to be waiver of any subsequent default. Waiver or breach of any provision of this Agreement shall not be deemed to be a waiver of any other or subsequent breach, and shall not be construed to be a modification of the terms of this Agreement unless this Agreement is modified as provided in paragraph twenty-two (22) below.

**17. CONFIDENTIALITY.**

Contractor further agrees to comply with the various provisions of the federal, state, and county laws, regulations, and ordinances providing that information and records kept, maintained, or accessible by Contractor in the course of providing services and work under this Agreement, shall be privileged, restricted, or confidential. Contractor agrees to keep confidential all such information and records. Disclosure of such confidential, privileged, or protected information shall be made by Contractor only with the express written consent of the County. Any disclosure of confidential information by Contractor without the County's written consent is solely and exclusively the legal responsibility of Contractor in all respects.

Notwithstanding anything in the Agreement to the contrary, names of persons receiving public social services are confidential and are to be protected from unauthorized disclosure in accordance with Title 45, Code of Federal Regulations Section 205.50, the Health Insurance Portability and Accountability Act of 1996, and Sections 10850 and 14100.2 of the Welfare and Institutions Code, and regulations adopted pursuant thereto. For the purpose of this Agreement, all information, records, and data elements pertaining to beneficiaries shall be protected by the provider from unauthorized disclosure.

**18. CONFLICTS.**

Contractor agrees that it has no interest, and shall not acquire any interest, direct or indirect, which would conflict in any manner or degree with the performance of the work and services under this Agreement.

**19. POST AGREEMENT COVENANT.**

Contractor agrees not to use any confidential, protected, or privileged information which is gained from the County in the course of providing services and work under this Agreement, for any personal benefit, gain, or enhancement. Further, Contractor agrees for a period of two years after the termination of this Agreement, not to seek or accept any employment with any entity, association, corporation, or person who, during the term of this Agreement, has had an adverse or conflicting interest with the County, or who has been an adverse party in litigation with the County, and concerning such, Contractor by virtue of this Agreement has gained access to the County's confidential, privileged, protected, or proprietary information.

**20. SEVERABILITY.**

If any portion of this Agreement or application thereof to any person or circumstance shall be declared invalid by a court of competent jurisdiction, or if it is found in contravention of any federal, state, or county statute, ordinance, or regulation, the remaining provisions of this Agreement, or the application thereof, shall not be invalidated thereby, and shall remain in full force and effect to the extent that the provisions of this Agreement are severable.

**21. FUNDING LIMITATION.**

The ability of County to enter this Agreement is based upon available funding from various sources. In the event that such funding fails, is reduced, or is modified, from one or more sources, County has the option to cancel, reduce, or modify this Agreement, or any of its terms within ten (10) days of its notifying Contractor of the cancellation, reduction, or modification of available funding. Any reduction or modification of this Agreement made pursuant to this provision must comply with the requirements of paragraph twenty-two (22) (Amendment).

**22. AMENDMENT.**

This Agreement may be modified, amended, changed, added to, or subtracted from, by the mutual consent of the parties hereto, if such amendment or change is in written form and executed with the same formalities as this Agreement, and attached to the original Agreement to maintain continuity.

**23. NOTICE.**

Any notice, communication, amendments, additions, or deletions to this Agreement, including change of address of either party during the terms of this Agreement, which Contractor or County shall be required, or may desire, to make, shall be in writing and may be personally served, or sent by prepaid first class mail to, the respective parties as follows:

County of Inyo  
County of Inyo Health & Human Services Department  
PO Drawer H Address  
Independence, CA 93526 City and State

Contractor:  
Redwood Toxicology Laboratory Name  
3650 Westwind Blvd. Address  
Santa Rosa, CA 95403-1053 City and State

**24. ENTIRE AGREEMENT.**

This Agreement contains the entire agreement of the parties, and no representations, inducements, promises, or agreements otherwise between the parties not embodied herein or incorporated herein by reference, shall be of any force or effect. Further, no term or provision hereof may be changed, waived, discharged, or terminated, unless the same be in writing executed by the parties hereto.

///

///

**AGREEMENT BETWEEN COUNTY OF INYO**  
**AND** Redwood Toxicology Laboratory  
**FOR THE PROVISION OF** Drug Testing and Supply **SERVICES**

IN WITNESS THEREOF, THE PARTIES HERETO HAVE SET THEIR HANDS AND SEALS  
THIS \_\_\_\_\_ DAY OF \_\_\_\_\_, \_\_\_\_\_.

**COUNTY OF INYO**

**CONTRACTOR**

By: \_\_\_\_\_  
Signature

DocuSigned by:  
By: Mary Tardel  
D43702611A5148 Signature

\_\_\_\_\_  
Print or Type Name

Mary Tardel, Senior Director, Government Services  
\_\_\_\_\_  
Print or Type Name

Dated: \_\_\_\_\_

Dated: 10/26/2020

APPROVED AS TO FORM AND LEGALITY:

County Counsel

Grace Chuchla

APPROVED AS TO ACCOUNTING FORM:

\_\_\_\_\_  
County Auditor

APPROVED AS TO PERSONNEL REQUIREMENTS:

\_\_\_\_\_  
Personnel Services

APPROVED AS TO INSURANCE REQUIREMENTS:

\_\_\_\_\_  
County Risk Manager

**ATTACHMENT A**

**AGREEMENT BETWEEN COUNTY OF INYO  
AND Redwood Toxicology Laboratory  
FOR THE PROVISION OF Drug Testing and Supply **SERVICES****

**TERM:**

**FROM:** November 1, 2020 **TO:** June 30, 2024

**SCOPE OF WORK:**

The Contractor shall provide all labor, materials, equipment, and incidentals to perform drug testing on samples provided by Inyo County and deliver the test results to the County.

The Contractor shall protect and maintain a chain of custody in collecting and processing test samples, including paper record keepings as shall be required by the requesting County department or agency to appropriately present evidence of any test results in any court or administrative proceeding.

The Contractor shall provide individual written reports and interpretation of any and all test results for the performance of such tests. Results report must include the levels of each item tested, including creatinine level provided to the authorized county employee on the results so the authorized county employee knows if the client is producing dilute urine samples.

The Contractor shall store samples with positive test results and/or tests with abnormalities for up to three (3) months in a secure warehouse. Negative test results will be stored for two (2) days. Chain of custody records, documentation and analytical records are maintained in secured storage for a period of three (3) years.

Collected urine samples will be picked up at the following locations:

Inyo County Health and Human Services

162-J Grove Street

Bishop, CA 93514

If requested, Contractor shall provide on-site training; and/or on-line Internet certified training on how to properly use the testing device; and/or provide on-site California Standards Training for Corrections (STC) certified Drug Abuse Recognition (DAR) training.

Amend Section 15. ASSIGNMENT as follows:

This is an agreement for the services of contractor. County has relied upon the skills, knowledge, experience, and training of Contractor as an inducement to enter into this Agreement. Contractor shall not assign or subcontract this Agreement, or any part of it, without the express written consent of County. Such consent shall not be unreasonably withheld. Further, Contractor shall not assign any monies due or to become due under this Agreement without the prior written consent of County.

**ATTACHMENT B**

**AGREEMENT BETWEEN COUNTY OF INYO  
AND Redwood Toxicology Laboratory  
FOR THE PROVISION OF Drug Testing and Supply **SERVICES****

**TERM:**

**FROM:** November 1, 2020      **TO:** June 30, 2024

**SCHEDULE OF FEES:**

See attached pricing schedule for testing devices, laboratory services and witness testimony.

Testing device orders will be shipped at no charge for ground service delivery. Expedited shipping of device orders will be charged at an "at cost" basis.

Laboratory testing shipping: Specimen pickup will be provided at no additional cost to County, when five (5) or more specimens are included in the shipment, through FedEx or UPS with overnight service delivery to laboratory in Santa Rosa, Ca. Shipments with fewer than five (5) specimens sent to lab will be assessed seven dollar (\$7.00) charge per shipment.



Redwood Toxicology Laboratory, Inc.  
 3650 Westwind Blvd.  
 Santa Rosa, CA 95403  
 T: +1 800 255 2159  
 F: +1 707 577 8102

**Pricing Schedule  
 Inyo County HHS  
 RFP for Drug Testing Services and Supplies**

*Below are line items from the Exhibit A as well as panels or tests that the County currently utilizes with RTL. However, this does not depict RTL's complete test menu. Should the County desire any additional tests or panels, please inquire with the Bid Analyst or your Sales Representative for available options and pricing.*

**Section I: Laboratory Drug & Alcohol Testing Services - Urine**

**Urine Lab Tests - Standard Drugs**

*Standard drugs include: Alcohol (Ethanol), Amphetamines/Methamphetamines, Barbiturates, Benzodiazepines, Buprenorphine, Cocaine, Ecstasy (MDMA), Heroin metabolite (6-MAM), Marijuana (THC), Methadone, Opiates, Oxycodone, PCP, Propoxyphene, Tramadol. The following adulterants may be included in each when counted as a drug: pH, Specific Gravity, Creatinine.*

TEST CODE	DRUG(S)	DESCRIPTION	PRICE PER SPECIMEN
H58	12	Urine 12 Panel Standard Drug Test w/ OXY & BUP - Screen Only	\$ 6.50
Various	1	Urine 1 Panel Standard Drug Test - Screen Only	\$ 5.50
N/A	1	Ethyl Glucuronide (EtG) Alcohol Metabolite - Add-On Screen Only*	\$ 0.75
049 or 050	1	Ethyl Glucuronide (EtG) Alcohol Metabolite - Stand-Alone Screen Only	\$ 5.25
Various	1	GC-MS, GC-FID or LC-MS/MS Standard Drug Confirmation - Per Drug	\$ 12.75
Various	1	Buprenorphine - Confirmation Only	\$ 18.00

*\*Items referred to as "Add-On" must be built into a routine panel used by the agency. This price will only apply in creating the new panel/test code. For example, if an agency wants a 5-drug standard panel with EtG, we would create a panel with a new test code and charge your agency a price equivalent to the 5-drug panel screen and the add-on EtG price.*

**Section II: Rapid Drug & Alcohol Screening Devices**

**ROUND INTEGRATED CUP SUBSTANCE ABUSE TEST DEVICE**

PART NUMBER	DRUG(S)	CONFIGURATION	PRICE PER DEVICE	BOX PRICE (25/BOX)
01 102 2096	12	EZ Cup II 12-Panel AMP1000/BAR/BUP/BZO/COC150/MAMP1000/MDMA/MOP300/MTD/OXY/PPX/THC	\$3.50	\$87.50
01 102 2203	7	iCup Urine Test 7 Panel Drug Screen Cup AMP500/COC150/MAMP500/OPI300/OXY100/THC50/PCP25 - <b>FFUO**</b>	\$2.67	\$66.75
01 102 2204	9	iCup Urine Test 9 Panel Drug Screen Cup OPI300/COC150/THC50/BZO300/PCP25/MAMP1000/BUP10/MTD300/ETG500 w/ adulteration (OX, CR, SG, pH) - <b>FFUO**</b>	\$3.67	\$91.75
01 102 2205	9	iCup Urine Test 9 Panel Drug Screen Cup ETG500/OPI300/COC300/THC50/AMP1000/mAMP1000/BUP10/OXY100/BZO300 w/ adulteration (OX, CR, SG, pH) - <b>FFUO**</b>	\$3.35	\$83.75
01 102 2206	9	iCup Urine Test 9 Panel Drug Screen Cup BUP10/COC150/MAMP500/OPI300/OXY100/BZO300/MDMA500/THC50/K2 - <b>FFUO**</b>	\$3.15	\$78.75
01 102 2207	12	iCup Urine Test 12 Panel Drug Screen Cup COC300/THC50/OPI2000/AMP1000/METH1000/PCP25/BZO300/BAR300/MTD300/BUP10/OXY100/ETG500 - <b>FFUO**</b>	\$3.27	\$81.75
01 102 2208	13	iCup Urine Test 13 Panel Drug Screen Cup ETG500/FEN20/TRAM200/AMP1000/BUP10/BZO300/COC300/MET1000/MDMA500/MTD300/OPI300/OXY100/THC50 - <b>FFUO**</b>	\$3.35	\$83.75
01 102 2209	14	AMP1000/BUP10/BZO300/COC300/EtG500/FYL20/MAMP1000/MDMA500/MTD300/OPI300/TRAM200/OXY100/THC50/K2 w/adulteration (Ox/Cr/SG/pH) - <b>FFUO**</b>	\$3.95	\$98.75
01 102 2210	15	iCup Urine Test 15 Panel Drug Screen Cup AMP500/BUP10/BZO300/COC150/EtG500/FYL20/MAMP500/MDMA500/MTD300/OPI300/OXY100/THC50/TRA200/6-AM w/adulteration (Ox/Cr/SG/pH) - <b>FFUO**</b>	\$3.97	\$99.25

**Device Order Shipping & Handling:** Device orders will be shipped at no charge for ground service delivery. Expedited shipping of device orders will be

**\*\*Forensic Use Only (FFUO) devices are intended for use only in drugs of abuse testing for law enforcement purposes. Appropriate users of such devices include, for example, court systems, police departments, probation/parole offices, juvenile detention centers, prisons, jails, correction centers and other similar law enforcement entities, or laboratories or other establishments performing forensic testing for these entities. Forensic Use Only devices are not designed, tested, developed, or labeled for use in other settings, such as clinical diagnostic or workplace settings.**

**ATTACHMENT C**

**AGREEMENT BETWEEN COUNTY OF INYO  
AND Redwood Toxicology Laboratory  
FOR THE PROVISION OF Drug Testing and Supply SERVICES**

**TERM:**

**FROM:** November 1, 2020      **TO:** June 30, 2024

**SEE ATTACHED INSURANCE PROVISIONS**



## **Attachment C: Insurance Requirements**

Consultant shall procure and maintain for the duration of the contract insurance against claims for injuries to persons or damages to property which may arise from or in connection with the performance of the work hereunder by the Consultant, its agents, representatives, or employees. Failure to carry specified lines or limits of coverage does not relieve contractor of obligation to indemnify Inyo County.

### **MINIMUM SCOPE AND LIMIT OF INSURANCE**

Coverage shall be at least as broad as shown below. If the Consultant maintains broader coverage and/or higher limits than the minimums shown above, Inyo County requires and shall be entitled to the broader coverage and/or the higher limits maintained by the contractor. Any available insurance proceeds in excess of the specified minimum limits of insurance and coverage shall be available to Inyo County. Failure to carry specified lines or limits of coverage does not in any way modify, limit, or relieve contractor of obligation to indemnify Inyo County.

**Commercial General Liability (CGL):** Insurance Services Office Form CG 00 01 covering CGL on an "occurrence" basis, including products and completed operations, property damage, bodily injury and personal & advertising injury with limits no less than \$1,000,000 per occurrence, \$2,000,000 aggregate.

**Automobile Liability:** Insurance Services Office Form Number CA 0001 covering, Code 1 (any auto), or if Consultant has no owned autos, Code 8 (hired) and 9 (non-owned), with limit no less than \$1,000,000 per accident for bodily injury and property damage.

**Workers' Compensation:** as required by the State of California, with Statutory Limits, and Employer's Liability Insurance with limit of no less than \$1,000,000 per accident for bodily injury or disease.

**Professional Liability (Medical Malpractice):** with limit no less than \$1,000,000 per occurrence or claim, \$2,000,000 aggregate.

**Cyber Liability:** as required if contractor will be accessing and managing electronic medical records, with limits not less than **\$1,000,000** per occurrence or claim, **\$2,000,000** aggregate. Coverage shall be sufficiently broad to respond to the duties and obligations related to electronic medical records, and shall include, but not be limited to, claims involving invasion of privacy violations, information theft, damage to or destruction of electronic information, release of private information, alteration of electronic information, extortion, and network security. The policy shall provide coverage for breach response costs as well as regulatory fines and penalties as well as credit monitoring expenses with limits sufficient to respond to these obligations.

### **OTHER REQUIRED INSURANCE PROVISIONS**

The insurance policies are to contain, or be endorsed to contain, the following provisions:

#### **Additional Insured Status**

Inyo County, its officers, officials, employees, and volunteers are to be covered as additional insureds on the CGL policy with respect to liability arising out of work or operations performed by or on behalf of the Consultant including materials, parts, or equipment furnished in

## **Attachment C: Insurance Requirements**

connection with such work or operations. General liability coverage can be provided in the form of an endorsement to the Consultant's insurance (at least as broad as ISO Form CG 20 10 11 85 or both CG 20 10, CG 20 26, CG 20 33, or CG 20 38; and CG 20 37 forms if later revisions used). On the Acord 25, please list Certificate Holder as follows: Inyo County, 163 May St, Bishop, CA 93514; risk@inyocounty.us.

### **Primary Coverage**

For any claims related to this contract, the Consultant's insurance coverage shall be primary insurance primary coverage at least as broad as ISO CG 20 01 04 13 as respects Inyo County, its officers, officials, employees, and volunteers. Any insurance or self-insurance maintained by Inyo County, its officers, officials, employees, or volunteers shall be excess of the Consultant's insurance and shall not contribute with it.

### **Notice of Cancellation**

Each insurance policy required above shall state that coverage shall not be canceled, except with notice to Inyo County.

### **Waiver of Subrogation**

Consultant hereby grants to Inyo County a waiver of any right to subrogation which any insurer of said Consultant may acquire against Inyo County by virtue of the payment of any loss under such insurance. Consultant agrees to obtain any endorsement that may be necessary to affect this waiver of subrogation, but this provision applies regardless of whether or not Inyo County has received a waiver of subrogation endorsement from the insurer.

### **Self-Insured Retentions**

Self-insured retentions must be declared to and approved by Inyo County. Inyo County may require the Consultant to provide proof of ability to pay losses and related investigations, claim administration, and defense expenses within the retention. The policy language shall provide, or be endorsed to provide, that the self-insured retention may be satisfied by either the named insured or Inyo County.

### **Acceptability of Insurers**

Insurance is to be placed with insurers authorized to conduct business in the state with a current A.M. Best's rating of no less than A:VII, unless otherwise acceptable to Inyo County.

### **Claims Made Policies**

If any of the required policies provide coverage on a claims-made basis:

1. The Retroactive Date must be shown and must be before the date of the contract or the beginning of contract work.
2. Insurance must be maintained and evidence of insurance must be provided for at least five (5) years after completion of the contract of work.
3. If coverage is canceled or non-renewed, and not replaced with another claims-made policy form with a Retroactive Date prior to the contract effective date, the Consultant must purchase "extended reporting" coverage for a minimum of five (5) years after completion of contract work.

### **Verification of Coverage**

## **Attachment C: Insurance Requirements**

Consultant shall furnish Inyo County with original Certificates of Insurance including all required amendatory endorsements (or copies of the applicable policy language effecting coverage required by this clause) and a copy of the Declarations and Endorsement Page of the CGL policy listing all policy endorsements to Inyo County before work begins. Electronic submission via [risk@inyocounty.us](mailto:risk@inyocounty.us) is preferable to paper forms. However, failure to obtain the required documents prior to the work beginning shall not waive the Consultant's obligation to provide them. Inyo County reserves the right to require complete, certified copies of all required insurance policies, including endorsements required by these specifications, at any time. Failure to carry specified lines or limits of coverage does not relieve contractor of obligation to indemnify Inyo County.

### **Subcontractors**

Consultant shall require and verify that all subcontractors maintain insurance meeting all the requirements stated herein, and Contractor shall ensure that Inyo County is an additional insured on insurance required from subcontractors.

### **Special Risks or Circumstances**

Inyo County reserves the right to modify these requirements, including limits, based on the nature of the risk, prior experience, insurer, coverage, or other special circumstances.

-end-



# County of Inyo



## Health & Human Services - First 5 DEPARTMENTAL - ACTION REQUIRED

**MEETING:** November 3, 2020

**FROM:** Jenna Rhoads

**SUBJECT:** First 5 and Bishop Friends of the Library collaboration on the Imagination Library Program.

---

### **RECOMMENDED ACTION:**

Request Board ratify and approve the Memorandum of Understanding between the County of Inyo First 5 Children and Families Commission and Bishop Friends of the Library, for the provision of the literacy program for Inyo County children from birth to age five (5) under Dolly Parton's Imagination Library Program, in an amount not to exceed \$1,886 for the period of November 1, 2020 through November 1, 2021, contingent upon the Board's approval of future budgets, and authorize the First 5 Director to sign, contingent upon all appropriate signatures being obtained.

### **SUMMARY/JUSTIFICATION:**

Reading aloud is an important way for a parent to help a baby learn vocabulary and to stimulate a baby's brain cells to grow stronger and develop more fully. Studies of the Dolly Parton Imagination Library Program indicate that it promotes change in home literacy environments, children's attitudes towards reading, and early literacy skills. Research shows that children who have access to books in the home have a more positive attitude about reading; This also encourages increased interactions between caregivers and children. This leads to promotion of emerging literacy skills and learning to read in the early grades, which therefore supports future academic success.

Each month, Dolly Parton's Imagination Library mails a high quality, age appropriate book to all registered children, addressed to them, at no cost to the child's family. The Imagination Library provides the infrastructure of the core program including managing the secure central database for the Book Order System and coordinating book selections and wholesale purchasing. It also incurs the cost of the program's administrative expenses and coordinates the monthly mailings.

### **BACKGROUND/HISTORY OF BOARD ACTIONS:**

The First 5 Inyo County Children and Families Commission has adopted a five (5) year strategic plan to promote the early development and well-being of children from prenatal to age five (5) and is committed to providing opportunities to enhance literacy. The Commission and Bishop Friends of the Library are committed to increasing language skills, literacy, and family resiliency by providing books to children ages 0-5. Additionally, Bishop Friends of the Library maintains an association of persons interested in supporting and strengthening the Bishop library system, enhancing its collection, and promoting its usefulness, and has determined that the Imagination Library Program will do so by creating and encouraging new generations of readers. Therefore, the Commission and Affiliate Partner will work collaboratively to implement the Program in the Inyo County library system.

**ALTERNATIVES AND CONSEQUENCES OF NEGATIVE ACTION:**

The Board could choose not to approve this MOU, thereby preventing the implementation of Dolly Parton's Imagination Library Program in Inyo County.

**OTHER AGENCY INVOLVEMENT:**

Bishop Friends of the Library as an Independent Affiliate Partner (501c3).

**FINANCING:**

This expense will be paid out of the First 6 budget (643000) in Professional Services (5265). No County General Funds.

**ATTACHMENTS:**

1. Friends of Library First 5 Imagination Library MOU

**APPROVALS:**

Jenna Rhoads	Created/Initiated - 10/22/2020
Darcy Ellis	Approved - 10/22/2020
Marilyn Mann	Approved - 10/22/2020
Melissa Best-Baker	Approved - 10/22/2020
Marshall Rudolph	Approved - 10/23/2020
Amy Shepherd	Approved - 10/27/2020
Marilyn Mann	Final Approval - 10/27/2020

## **MEMORANDUM OF UNDERSTANDING**

This Memorandum of Understanding (hereafter “MOU”), is effective as of the date of execution set forth below by and between First 5 Inyo County Children and Families Commission (hereafter the “Commission”) and Bishop Friends of the Library (hereafter the “Affiliate Partner”) individually referred to herein as a “party” and collectively as the “parties,” for the provision of the literacy program for Inyo County children from birth to age five (5) under the Dolly Parton’s Imagination Library Program (hereafter the “Program”).

### **BACKGROUND**

Reading aloud is an important way for a parent to help a baby learn vocabulary and to stimulate a baby’s brain cells to grow stronger and develop more fully. Studies of the Dolly Parton Imagination Library program indicate promote changes in home literacy environments, children’s attitudes towards reading, and early literacy skills. Research shows that children who have access to books in the home helps them have a positive attitude about reading and encourages increased interactions between caregivers and children. This leads to increased emerging literacy skills and learning to read in the early grades supports future academic success.

### **RECITALS**

WHEREAS:

- a. The Commission has adopted a five (5) year strategic plan to promote the early development and well-being of Inyo County children from prenatal to age five (5); and
- b. The Commission is committed to providing children in Inyo County opportunities to enhance literacy; and
- c. The Commission and the Affiliate Partner are committed to increasing language skills, literacy, and family resiliency by providing books to children ages 0-5; and
- d. The Affiliate Partner maintains an association of persons interested in supporting and strengthening the Bishop library system, enhancing its collection, and promoting its usefulness and has determined that the Program will support and strengthen the library system by creating and encouraging new generations of readers; and
- e. The Commission and the Affiliate Partner will work collaboratively to implement the Program; strengthening the Inyo County library system by creating a new audience of readers from the community.

THEREFORE, the Commission and the Affiliate Partner hereto agree as follows:

#### **1. TERM.**

This MOU shall commence on November 1, 2020, and expire one year thereafter. The MOU will be automatically renewed each year unless written notification is provided by either party to the other within sixty days of the annual anniversary of the execution of the MOU.

**2. DESIGNATED REPRESENTATIVE.**

The First 5 Director of the Commission is the authorized representative of the Commission and will administer this MOU. The President of Bishop Friends of the Library is the authorized representative of the Affiliate Party. Parties shall give advanced notice, in writing, of any change in their designated representative.

**3. COMMISSION DUTIES AND RESPONSIBILITIES.**

- 3.1. The Commission shall secure at its own expense, all personnel required to manage all administrative and financial aspects of the Program. All management shall be conducted by the Commission or under its supervision, and all personnel engaged in the work shall be qualified to perform such services.
- 3.2. The Commission shall secure adequate funding to carry out its obligations under this MOU. The parties understand and agree that this MOU does not require the Affiliate Partner to provide any funding to the Commission.
- 3.3. The Commission shall pay, by the first of each month, the monthly invoice produced by the Program.
- 3.4. The Commission understands that the cost of books and postage is currently approximately \$25 a child per year. The Commission acknowledges that this amount is subject to change. The Commission may leverage other funds to support Program sustainability, and will hold and retain any additional funds acquired to support the program.

**4. BISHOP FRIENDS OF LIBRARY DUTIES AND RESPONSIBILITIES.** The Affiliate Partner shall:

- 4.1. Enter into a Memorandum of Understanding with the Program designating the Affiliate Partner as the Program’s non-profit affiliate for the limited purpose of being the entity qualified by the United States Postal Service for non-profit mailing rates.
- 4.2. Remain the Program’s designated non-profit affiliate throughout the term of this MOU.

**5. INDEMNIFICATION.**

- 5.1. Definitions. For purposes of this Section 6. “Affiliate Partner” shall include Affiliate Partner, its officers, employees, servants, agents, or subcontractors, or anyone directly or indirectly employed by either Affiliate Partner or its subcontractors, in the performance of this MOU. “Commission” shall include Commission, its officers, agents, employees, and volunteers.
- 5.2. Commission shall defend, indemnify, and hold harmless the Affiliate Partner, its elected and appointed councils, boards, officers, agents from and against any and all claims, causes of



action, proceedings, penalties, fines, losses, damages, costs, expenses or other liabilities of whatever nature, including, without limitation, settlement costs and reasonable attorney fees, court costs and other expenses incurred in investigation, prosecuting or defending any claim or action, or any threatened claim or action, which is based upon or arises out of or in connection with the intentional or negligent acts or omissions of Commission, or any of Commission's Officers, agents, employees, contractors or subcontractors. Commission shall not be required to indemnify Affiliate Partner for such loss or damage as is caused by the sole active negligence or willful misconduct of the Affiliate Partner.

## **6. GENERAL PROVISIONS.**

- 6.1. This MOU constitutes the entire agreement between the parties with respect to the subject matter and supersedes all prior and contemporaneous agreements and understandings of the parties. This MOU may be amended only by written, mutual consent of both parties.
- 6.2. This MOU may be terminated by either party, with or without cause, upon sixty (60) days written notice to the other party. The MOU will automatically terminate if, for any reason, the Affiliate Partner is no longer designated as the Program's non-profit affiliate.

## **7. NOTICES.**

Any notice required or permitted to be given under this MOU shall be in writing and shall be served by certified mail, return receipt requested, or personal service upon the other party. When service is by certified mail, service shall be conclusively deemed complete after deposit in the United States mail, postage prepaid, addressed to the party to whom such notice is to be given as hereafter provided.

Notices shall be addressed as follows:

If to the COMMISSION:

First 5 Director  
FIRST 5 INYO County of Inyo  
568 West Line Street  
Bishop, CA 93514

If to the AFFILIATE PARTNER:

President  
BISHOP FRIENDS OF THE LIBRARY  
PO Box 244  
Bishop, CA 03515

8. **AUTHORITY.** By signing below, the parties to this MOU represent that they have the authority to enter into this MOU and that they agree to abide by the terms and conditions specified above.

9. **INDEPENDENT AFFILIATE PARTNER.** Both parties understand and agree that Affiliate Partner is an independent contractor and that no relationship of employer-employee exists between the Commission and Affiliate Partner. Neither Affiliate Partner nor Affiliate Partner’s assigned personnel shall be entitled to any benefits payable to employees of the Commission.
10. **GOVERNING LAW.** This MOU is governed and construed in accordance with the laws of the State of California. In the event of a dispute or claim arising out of the MOU, venue shall be in the Superior Court of the State of California for the County of Inyo.
11. **INTEGRATION.** This MOU, including the language preceding the MOU and the MOU itself, represents the entire understanding of Affiliate Partner and Commission as to those matters contained herein and supersedes all prior negotiations, representations, or agreements, both written and oral. This MOU may be amended only by written instrument signed by the Commission and Affiliate Partner.

IN WITNESS WHEREOF, the parties have executed this agreement on the date shown next to their respective signatures.

First 5 Inyo County Children and Families Commission

\_\_\_\_\_  
First 5 Director

\_\_\_\_\_  
Date

Bishop Friends of Library

  
\_\_\_\_\_  
President

09/29/2020  
\_\_\_\_\_  
Date

APPROVED AS TO FORM

  
\_\_\_\_\_  
County Counsel

10/2/20  
\_\_\_\_\_  
Date



# County of Inyo



## Clerk of the Board

### DEPARTMENTAL - ACTION REQUIRED

**MEETING:** November 3, 2020

**FROM:** Assistant Clerk of the Board

**SUBJECT:** Approval of Board of Supervisors Meeting Minutes

---

**RECOMMENDED ACTION:**

Request Board approve the minutes of the regular Board of Supervisors meeting of October 27, 2020.

**SUMMARY/JUSTIFICATION:**

The Board is required to keep minutes of its proceedings. Once the Board has approved the minutes as requested, the minutes will be made available to the public via the County's webpage, [www.inyocounty.us](http://www.inyocounty.us).

**BACKGROUND/HISTORY OF BOARD ACTIONS:**

N/A

**ALTERNATIVES AND CONSEQUENCES OF NEGATIVE ACTION:**

N/A

**OTHER AGENCY INVOLVEMENT:**

N/A

**FINANCING:**

N/A

**ATTACHMENTS:**

**APPROVALS:**

Darcy Ellis  
Darcy Ellis

Created/Initiated - 10/28/2020  
Final Approval - 10/28/2020



Michael Errante, Public Works Director  
Chris Cash, Deputy Director

## DEPARTMENT OF PUBLIC WORKS

P.O. DRAWER Q  
INDEPENDENCE, CA 93526  
PHONE: (760) 878-0201  
FAX: (760) 878-2001

COUNTY  
OF  
INYO

### NORTHERN INYO AIRPORT ADVISORY COMMITTEE MEETING AGENDA

Board Clerk

**Meeting Date:** Monday, November 2, 2020, 5:00 PM

**Meeting Location:** Bishop Airport Terminal Building  
703 Airport Road, Bishop, CA

- I. Call To Order
- II. Pledge of Allegiance
- III. Approval of minutes from the February 3, 2020 meeting
- IV. Old Business
  - a. Airport Improvement Project Update
- V. New Business
  - a. Introduction of Deputy Director of Public Works Airports
- VI. Supervisor of Airport Operations Report
- VII. Public Comment
- VIII. Next meeting date and time
  - a. Feb. 1<sup>st</sup>, 2021 at 5:00 PM
- IX. Adjourn

**Northern Inyo Airport Advisory Committee**  
**Minutes—February 3, 2020**

Present: Geoff Pope, Eileen Burger, Harivanden Bhakta, Wayne Sayer, Peter Tracy

**I. Call to Order**

Geoff called the meeting to order at 5:04 PM.

**II. Pledge of Allegiance**

**III. Approval of Minutes**

The minutes from the meeting of November 4, 2019 were approved.

**IV. Old Business**

a. Airport Improvement Project update. Mike Errante reported that the Qualcomm contract was in place. The start date depends on the weather. Runway 12-30 is under design (\$7.8 million FAA grant) with construction expected to start late spring or early summer.

Ashley Helms and Mike attended a meeting in LA with the FAA, along with representatives of Mammoth Mountain, the town of Mammoth Lakes, and others. These meetings are monthly. There is now a letter of intent from Sky West.

Recently there were scoping meetings, one in Bishop and one in Mammoth Lakes. For the most part there were no objections raised. One Bishop resident (Buck, present at this meeting as well as at the scoping meeting in Bishop) did raise a concern. He would like to see a full EIS (environmental impact statement) completed. That will be determined by the EA (environmental assessment). The EA might determine that there is no significant environmental impact and an EIS is not needed. Buck is very concerned about jet fuel and its effect on the environment. He would like to see a study of the micro climate in the valley. He was asked to present his concerns to the consultants.

A new (or newer) Airport Rescue and Fire Fighting (ARFF) vehicle is needed. The current one at Bishop Airport does not have the required capacity. The county is working to get funding for gear and training.

Although it was not on the agenda, Geoff raised the question of additional old business, pertaining to the potential closure of runway 8-26. What was the outcome of the NIAAC's resolution that was presented to the county? Mike reported that no steps had been taken yet. Pete delivered the resolution to the county (Ashley) and was told that the county had no plan to discuss the issue further—the FAA wants the runway shut down. There may be a concern that raising the issue of 8-26 could jeopardize the grant. The NIAAC suggested that a letter from the county staff to the FAA would show the local support for and safety reasons for not closing 8-26.

Mike reported on the tentative new locations for the July 4 fireworks, since they can no longer take place at the airport. He has talked to the fire chief about a couple locations, and it seems that the tricounty fairgrounds will be the new location. There is another meeting coming up. The fairgrounds management is excited about it, and about working jointly with the city of Bishop.

## **V. New Business**

- a. None.

## **VI. Supervisor of Airport Operations Report (Steve)**

Steve reported: It has been a quiet winter so far, with only a little bit of plowing snow around Thanksgiving, with the 1962 truck. Mike has been working to get a new truck, from the '80's, for the airport. It will be purchased from the City of Bishop for \$1, and will be the plow truck.

Steve noted that there have been a couple cars broken into at Sierra Life Flight's hangar. The sheriff came out and took a report. The ambulance drivers would rather have the gates open. But now all the gates are locked. Mike said he has tried to get the manufacturer of the keypads to fix them. The keypads function erratically.

The fuel numbers are down for some reason. Military purchases are down. However, this Sunday the Marines will be here for a few days, and they buy a lot in a short time.

Still planning to get Jack trained in a fuel school, when available closer.

Current maintenance includes going around and pulling old stakes and metal posts. Also working on setting up a permanent database for notams, so that when notams expire they don't just disappear.

There is a new air ambulance service (helicopter) that is coming into Lone Pine for about a year. They want to put in a permanent tank for jet fuel, so that it isn't just available with a call out. It will be a first for Lone Pine, to have self-serve jet-A, and it will be good for the airport and the county.

## **VII. Public Comment**

Buck said that he has been a grant writer for the Bishop Paiute Tribe for many years, and would like to see the county involve the tribe in the airport project. There are lots of kids who have done firefighting training. The tribe may also be able to get funding from the Federal Government for things that could benefit the airport that would not be funded by the FAA.

Rick Pucci brought up the fact that this airport, regardless of scheduled airline service, is necessary for the viability of the region. There are many other uses of the airport that benefit the residents of the county including FedEx flights, Ameriflight, air ambulance services (Sierra Life Flight), and summer firefighting. Steve pointed out that additionally, the Office of Emergency Services in Sacramento considers the airport critically important, as Bishop airport is the place where emergency services would go to serve this region of the state.

**VIII. Next meeting date and time**

- a. Monday, May 4, 2020 at 5:00 PM.

**IX. Adjourn**

Meeting adjourned at 5:55 PM.